



## Furuno CAN bus Network Design Guide

This document describes the Furuno CAN bus and shows how to create Furuno CAN bus networks and how to install Furuno CAN bus devices.

### 1. What is Furuno CAN bus?

Furuno CAN bus devices comply with NMEA 2000 physical and protocol standards, but these devices can be installed in a slightly different way from the NMEA2000 standard to make a network creation easier.

#### NMEA 2000

NMEA 2000 is a combined electrical and data specification for a marine data network for communication between marine electronic devices such as depth finders, chartplotters, navigation instruments, engines, tank level sensors and GPS receivers. NMEA 2000, a successor to the NMEA 0183 standard, connects devices using CAN (Controller Area Network) technology originally developed for the automotive industry. CAN based networks were developed to function in electrically noisy environments.

#### NMEA 2000 vs. NMEA 0183

NMEA 2000 is a serial data “network” operating at 250k bps and NMEA 0183 is a serial data “interface” operating at 4.8k bps. NMEA 2000 networks allows multiple electric devices to be connected together on a common channel for the purpose of easily sharing information.

Table 1 NMEA 2000 vs. NMEA 0183

	NMEA 2000	NMEA 0183
Connector	Standard connectors (Plug and play)	Different connectors of each manufacturer
Data rate	250k bits/second	4.8k (38.4k) bits/second
Protocol	Compact binary message	ASC II serial communication
	<b>Multi-talker, multi-listener</b>	Single-talker, multi-listener
	Network	Serial communication (Point to point communication)

#### CAN vs. Ethernet

NMEA decided to choose CAN to develop a low-cost, self-configuring, and multi-master network. The table below shows other advantages of CAN over Ethernet.

Table 2 CAN vs. Ethernet

	CAN	Ethernet
Power Consumption	Lower	Higher
Bandwidth	Low	High
Collision Avoidance	Yes	<b>No avoidance</b> (Collision detection)
Message Priority	Yes	<b>No</b>

## 1.2 Network Connections

Like a NMEA 2000 network, Furuno CAN bus networks consist of lengths of network Backbone cable with a defined beginning and end. A resistive terminator (120 ohms, 1/4 W) is connected at each end to reduce transmission-line reflections. See Fig.1.

Furuno Can bus devices are connected to the network backbone cable with a single Drop cable. The maximum cable length of the drop cable is 6 m and the sum of the drop cables should not exceed 60 m.

Power supply or battery connections are made to the network backbone cable either directly or by means of a dedicated cable. Some Furuno CAN bus devices can power the network through the network connector.

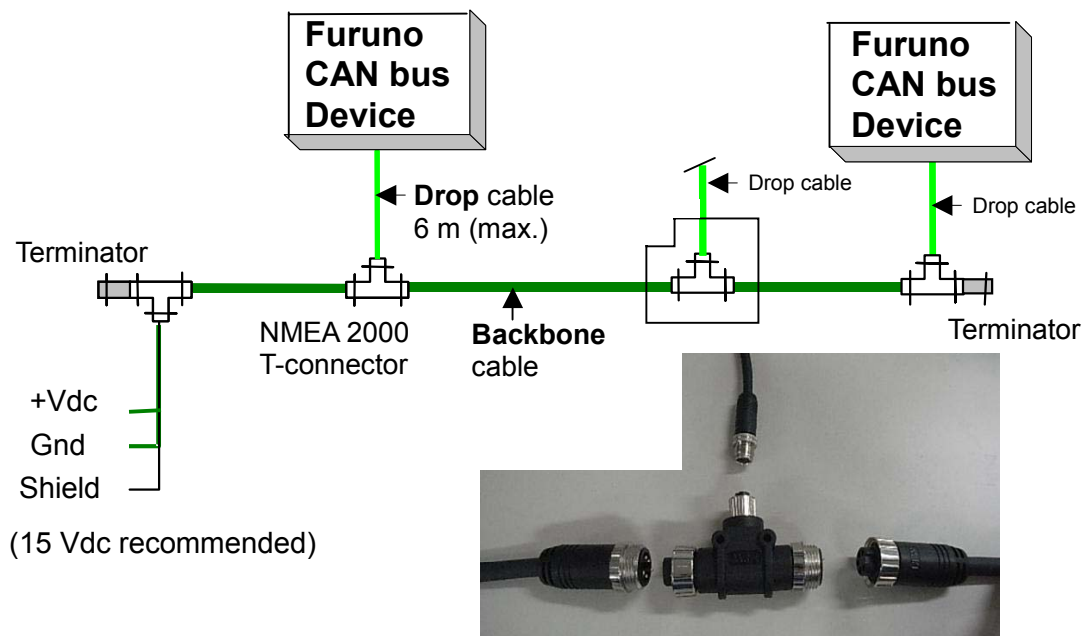

Fig.1 Typical Furuno CAN bus Network Topology

The T-connector is used to construct a Furuno CAN bus backbone and to extend the backbone with appropriate lengths of backbone cable. The T-connectors can be separated by the backbone cable or connected directly together. When constructing the network, take the following into account;

- 1) Use one T-connector per device (see Fig.3).
- 2) Use the sides of the T-connectors to construct the backbone of the network. (Furuno CAN bus device with an internal terminator is connected to the side of the T-connector.) Fig.5
- 3) Use the top of the T-connector to attach a device.

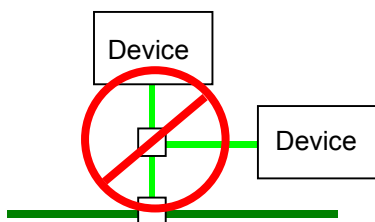

Fig.2

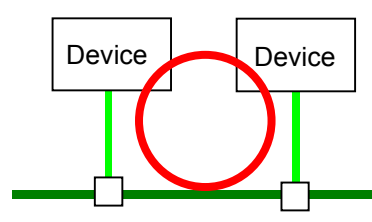

Fig.3

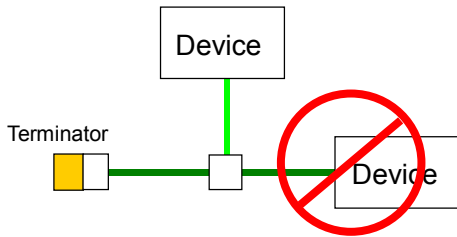

Fig.4

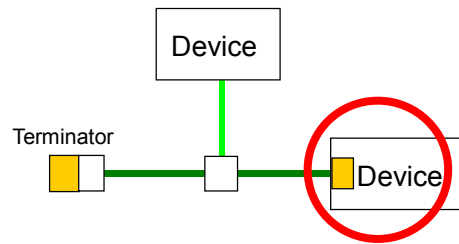

Fig.5

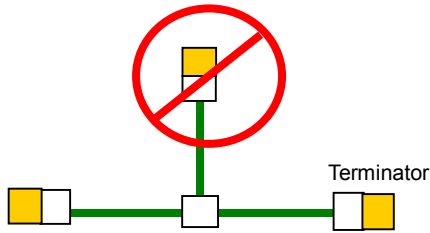

Fig.6

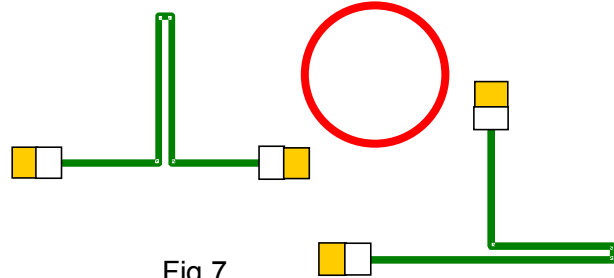

Fig.7

Daisy Chain Connection Example

A Furuno CAN bus device, the FI-50, can be connected in daisy chain without the T-connector as shown in Fig.8.

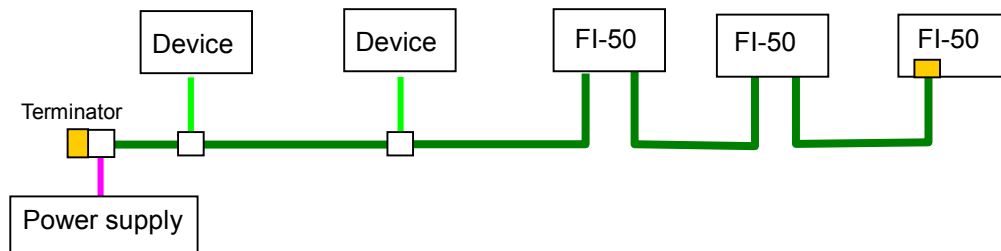

Fig.8 Daisy chain connection of FI-50 series

The network connection is made by two methods for all types of connections: a connector and barrier strips. The connections are used;

- (a) For connecting segments of backbone cable together
- (b) For connecting terminations at the two ends of the cable
- (c) For connecting the network power source, and
- (d) For connecting devices.

Two types of the connector; “Mini” for heavy cable and “Micro” for light cable are used for NMEA 2000 network connections.

Barrier strips are only recommended when the connections are made in a protected location, or when they are installed in a weatherproof enclosure. Two methods may be used together in the same network.

Fig.9 shows a typical network connection made with barrier strips. When used for termination resistors, all five wires are attached to the barrier strip and the termination resistor, 120 ohms, 1/4 W connected between NET-H and NET-L. No connections are allowed to the other terminals.

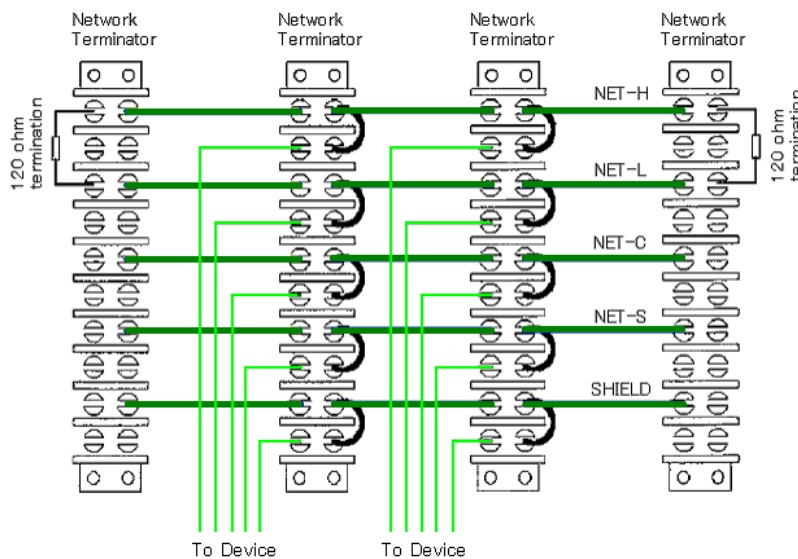

Fig.9 Barrier strips

“Star” type connections are not allowed.

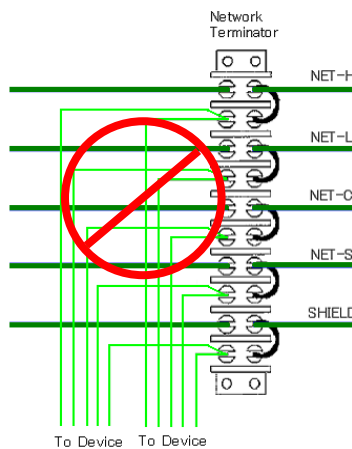

Fig.10 Barrier strip - Improper connection

### 1.3 Network Cable

Two types of cable are used in the network, heavy cable and light cable. The selection of cable type for various portions (including the drop cable) of the network depends on the number of Network loads attached, the length of the network cables, and the location of the specific cable in the network.

#### Heavy cable

The heavy cable is five-wire constructed with two individually twisted-shielded pairs enclosed by an overall shield with a shield drain wire connecting all three shields. Table 3 shows the wire colors of the heavy cable (10 mm diameter, MAX. 8 A).

Table 3 Wire colors of heavy cable

Name	Pair	Color	Size	Pin#
Shield	Drain	Bare	18AWG	1
NET-S	Power	Red	16AWG	2
NET-C	Power	Black	16AWG	3
NET-H	Signal	White	18AWG	4
NET-L	Signal	Blue	18AWG	5

Light cable

The light cable is five-wire constructed with two individually twisted-shielded pairs enclosed by an overall shield with a shield drain wire connecting all three shields. Table 4 shows wire colors of the light cable (6 mm diameter, MAX. 1 A).

Table 4 Wire colors of light cable

Name	Pair	Color	Size	Pin#
Shield	Drain	Bare	22AWG	1
NET-S	Power	Red	22AWG	2
NET-C	Power	Black	22AWG	3
NET-H	Signal	White	24AWG	4
NET-L	Signal	Blue	24AWG	5

### 1.4 Network Connector

Furuno CAN bus network uses NMEA2000 standard 5-pin connectors for the network connections: “Mini” for the heavy cable and “Micro” for the light cable. Note that FI-50 series uses the L-type Micro connector.

Table 5 and Figs.11 to 14 show Furuno CAN bus connector pin functions and face views. These connectors comply with NMEA2000 LTW connector standard.

Table 5 Pin function of Furuno NMEA 2000 LTW connector

Pin No.	Function	Color
1	Shield	Bare
2	NET-S (Power supply positive, +V)	Red <span style="color:red">■</span>
3	NET-C (Power supply common, -V)	Black <span style="color:black">■</span>
4	NET-H (CAN-H)	White <span style="border: 1px solid black; display: inline-block; width: 10px; height: 10px;"></span>
5	NET-L (CAN-L)	Blue <span style="color:blue">■</span>

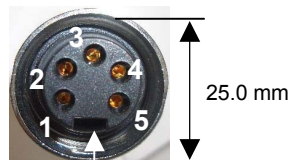

Fig.11 Female Mini connector

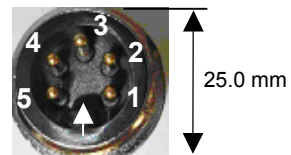

Fig.12 Male Mini connector



Fig.13 Female Micro connector

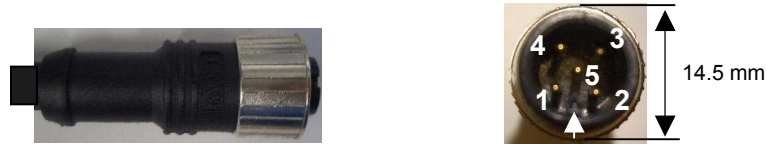

Fig.14 Male Micro connector

The following list shows the backbone/drop cables. To extend the backbone cable, use the cable with a male connector on one end and a female connector on the other. For example, if you need 15 meter cable, connect two 6 m cables, a 2 m cable, and a 1 m cable. Either heavy cable or light cable is used as a backbone cable.

Note that the length of drop cable is 0 to 6 m.

Parts Name	Type	Code Number	Connector fitted
CAN bus light cable (1 m)	M12-05BM+05BF-010	000-167-962	Male and Female
CAN bus light cable (2 m)	M12-05BM+05BF-020	000-167-963	Male and Female
CAN bus light cable (6 m)	M12-05BM+05BF-060	00-167-964	Male and Female
CAN bus light cable (1 m)	M12-05BFFM-010	000-167-965	Female
CAN bus light cable (2 m)	M12-05BFFM-020	000-167-966	Female
CAN bus light cable (6 m)	M12-05BFFM-060	000-167-967	Female
CAN bus heavy cable (1 m)	CB-05PM+05BF-010	000-167-968	Male and Female
CAN bus heavy cable (2 m)	CB-05PM+05BF-020	000-167-969	Male and Female
CAN bus heavy cable (6 m)	CB-05PM+05BF-060	000-167-970	Male and Female
CAN bus heavy cable (1 m)	CB-05BFFM-010	000-167-971	Female
CAN bus heavy cable (2 m)	CB-05BFFM-020	000-167-972	Female
CAN bus heavy cable (6 m)	CB-05BFFM-060	000-167-973	Female



Fig.15 CAN bus light cable with a connector at both ends



Fig.16 CAN bus light cable with a connector at one end

### 1.5 T-connector

There are two types of T-connectors: Mini for heavy backbone cable, Fig.17 and Micro for light backbone cable, Fig.18.

Parts Name	Type	Code Number	Remarks
Mini T-connector	NC-050505-FMF-TS001	000-160-507	for heavy cable
Micro T-connector	SS-050505-FMF-TS001	000-168-603	for light cable



Fig.17 Mini T-connector (NC-050505-FMF-TS001)

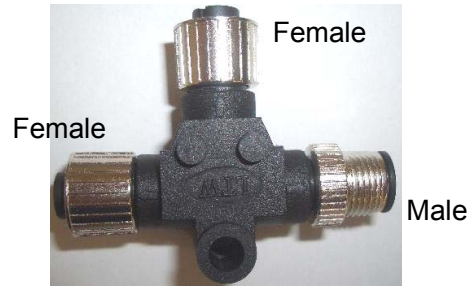

Fig.18 Micro T-connector (SS-050505-FMF-TS001)

### 1.6 Terminator

Furuno CAN bus 120-ohm terminators are available with the following part numbers. The terminator should be attached at each end of the backbone cable.

The terminator has a 120-ohm resistor across pins #4 and #5.

Parts Name	Type	Code Number	Remarks
Male terminator	LTWMN-05AMMT-SL8001	000-160-508	Mini connector, Fig.19
Female terminator	LTWMN-05AFFT-SL8001	000-160-509	Mini connector, Fig.20
Male terminator	LTWMC-05BMMT-SL8001	000-168-604	Micro connector, Fig.21
Female terminator	LTWMC-05BFFT-SL8001	000-168-605	Micro connector, Fig.22



Fig.19 Male terminator for heavy cable



Fig.20 Female terminator for heavy cable



Fig.21 Male terminator for light cable



Fig.22 Female terminator for light cable

### Termination with MFD

The MFD unit is terminated with a terminator as shown in Fig.23, because the unit does not have the internal terminator.

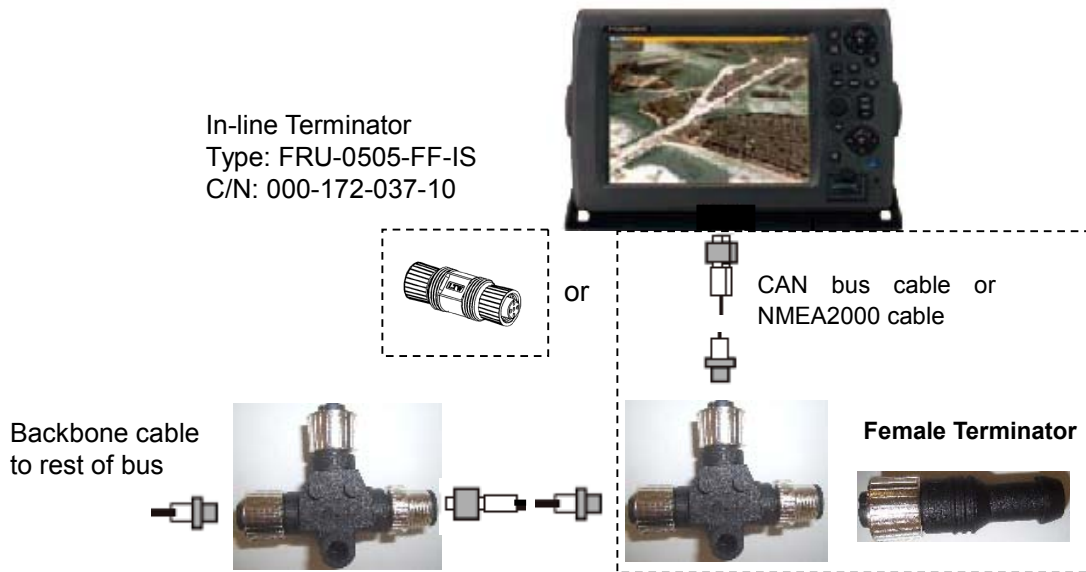

Fig.23 Termination with MFD

### Internal Terminator

Furuno CAN bus devices, DRS, FI-50, GP-330B, SC-30, and WS-200 have an internal terminator, so these devices can be connected to the backbone cable as shown in Fig.24. By connecting the device to the backbone cable, the cable length between the T-connector and the device can be extended more than 6 m.

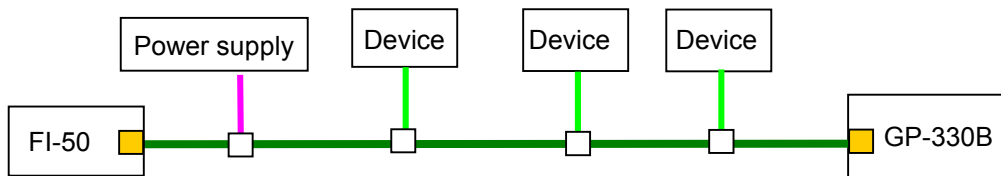

Fig.24 Using internal terminator at both ends of backbone cable

To activate the internal terminator;

#### (a) DRS

The resistor assembly, 120 OHM-1007#24-L50, C/N: 000-167-746 is connected between #5 and #6 of J603 in the radome antenna and #4 and #5 of TB102 in the open type antenna.

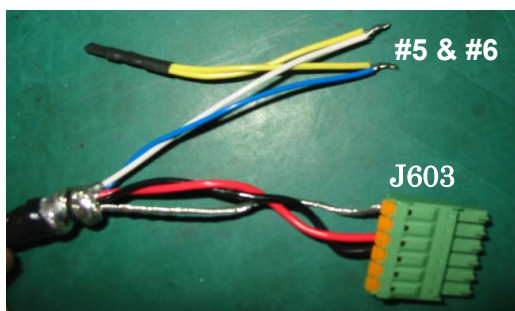

Fig.25 Terminator in DRS2D/4D

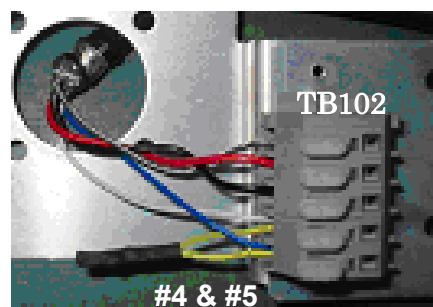

Fig.26 Terminator in DRS4A/6A/12A/25A



(b) GP-330B

The supplied contact pin, 05-251-01 (C/N: 000-168-935) is inserted into socket #5 in the connector before connecting it to the antenna.

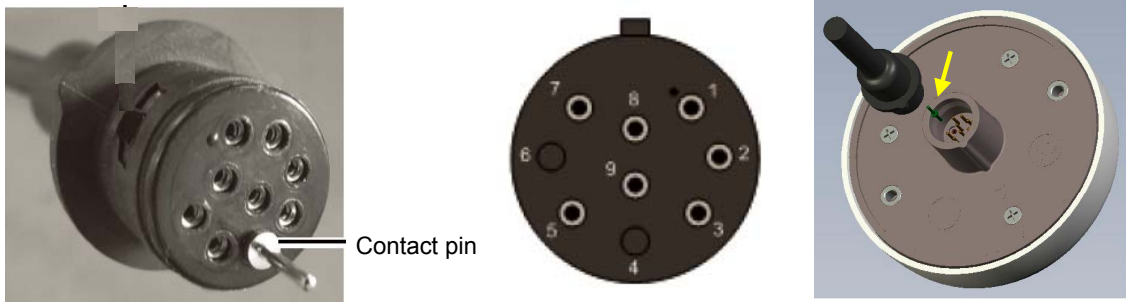

Fig.27 Termination on GP-330B

(c) WS-200

The same contact pin as GP-330B is used for termination. (Type: 05-251-01)

(d) SC-30

Use the cable, MJ-A10SPF0015-15/30 of which 10-pin MJ connector has a 120-ohm resistor connected between pins #4 and #5.

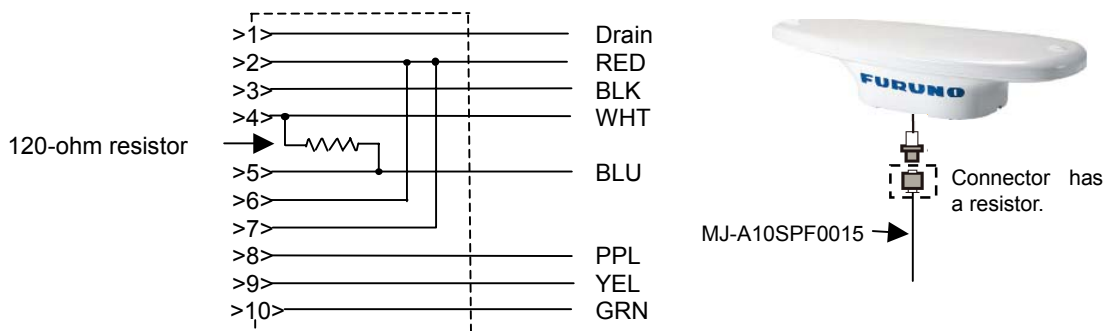

Fig.28 Termination on SC-30

(e) FI-50

The terminal resistor is on and off through “Setup2” menu. To show setup2 menu, press following two keys at a time until the menu appears.

FI-50 series	To get into Setup2 mode, press	To choose item, press
FI-501/502/505	3rd and 4th keys from left	MODE
FI-503	LOWER and SELECT/CLEAR	Upper
FI-504	APP/TRUE and SELECT/CLEAR	DISP
FI-506	BRILL and Left arrow key (To save the change, press BRILL and Left arrow key again.)	Right arrow key

### 1.7 Network Power Supply

The Furuno CAN bus network devices operate at 9.0 to 16.0 Vdc. Ensure that the voltage of power supply to the device located farthest from the power source on the network is 9.0 Vdc or more.

The total current carrying capacity of the network depends on the choice of backbone cable and where the power is connected into that cable. The heavy cable is rated at 8 Amps and the light cable is rated at 1 Amp. Both of these ratings are at 20 degrees Celsius and must be de-rated with temperature. If the power connection is made to the center of the backbone cable, then the current carrying capacity is effectively doubled as the full capacity is available to each end of the network from the power connection point.

#### For CAN bus network with DRS

The DRS series outputs 15 Vdc, 1A from the network port to the CAN bus devices in the network. The power supply cable connection to the network is not necessary when the DRS is in the network. The power connection is at either the end or middle of the network.

Note that the pin assignment of the network port differs between radome and open antennas.

J603 in Radome Antenna			TB102 in Open Antenna		
Pin No.	Signal name	Remarks	Pin No.	Signal name	Remarks
1	SHIELD		1	SHIELD	
2	NC		2	NET_S	V+ (+15V)
3	NET_S	V+ (+15V)	3	NET_C	V-
4	NET_C	V-	4	NET_H	CAN_H
5	NET_H	CAN_H	5	NET_L	CAN_L
6	NET_L	CAN_L			

The number of the devices that can be connected to the network powered from the DRS depends mainly on the network load. For example, Weather Station, WS-200 and Satellite Compass, SC-30 are not connected to the DRS via CAN bus at the same time due to overload. The following section describes the network load calculation.

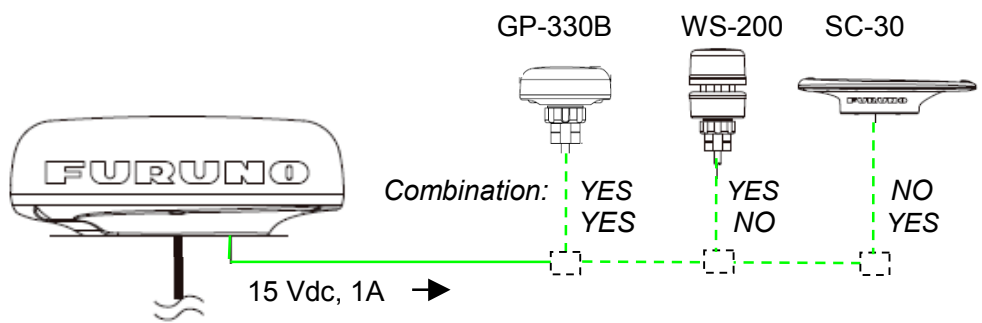

Fig.29 Furuno CAN bus powered from DRS  
(No network power cable required)

When both the SC-30 and WS-200 are connected to the network with the DRS, disconnect pins 3 and 4 of J603 on the CAN bus interface board, 03P9462 in the DRS and connect an external 15-Vdc power supply to the network backbone cable.

Fig.30 shows the simplified circuit diagram of power supply circuit on the CAN bus interface board, 03P9462. The circuit is protected by a 1.5 A onboard fuse.

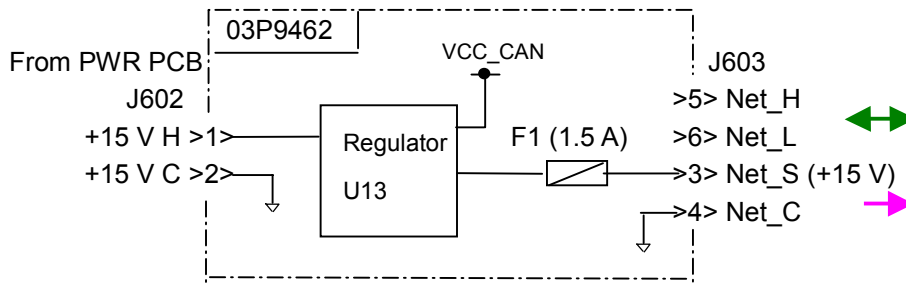

Fig.30 CAN bus interface board in DRS

**For CAN bus network with MFD**

The Furuno CAN bus network is powered through the MFD unit: the power supply or battery is connected to pins #17 (NET\_S\_IN) and #18 (NET\_C\_IN) of 18-pin “DATA 2” connector on MFD8/12/BB with a 1-A in-line fuse and switch. See Figs 31 and 32.

The output voltage of the power supply is ideally 15 Vdc +/-5%, ripple 0.25 Vp-p or less as NMEA2000 standard, considering input line variation and DC drop in the network power cable. Do NOT connect the network to a 24 Vdc power supply.

“Isolation” from other devices power and grounds of the power supply must be maintained.

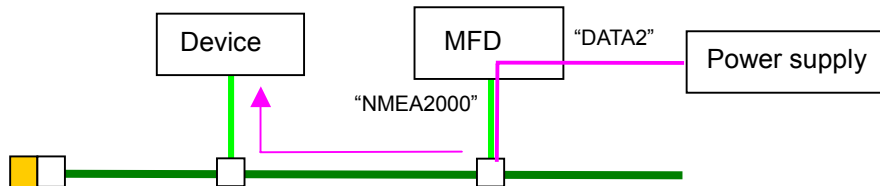

Fig.31 Connection of power supply to network through MFD

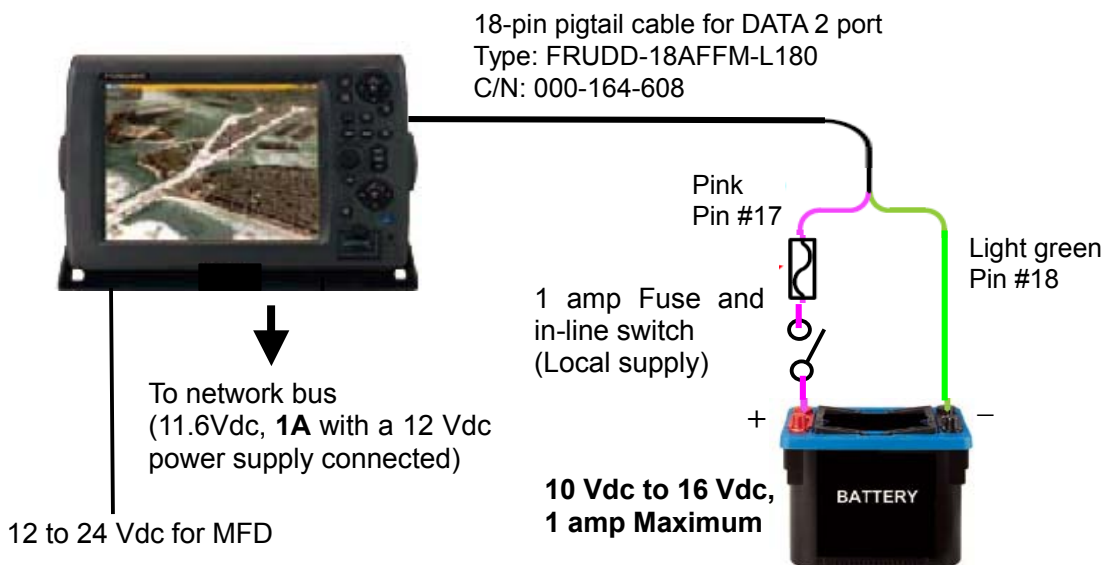

Fig.32 Connection of network power supply to MFD

A diode and a polyswitch (SMDC110F) on CONT2 board in the MFD unit protect the interface circuit against over-current and short-circuit. See Fig.33.

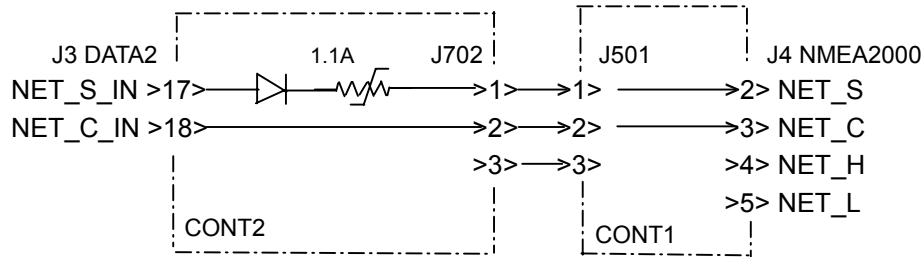

Fig.33 Protection of network power circuit in MFD

The maximum length of the network backbone is 150 m when the heavy cable is used and 50 m when the light cable is used. More details are explained in the “CAN bus Network limitations” section.

### 1.8 Network Grounding

The network is grounded at a SINGLE location. This is normally done at the power supply connection to the network and should be well connected to the vessel’s grounding system. There must be no other ground connections on the network to avoid the problem of ground loops, which can harm the network performance.

### 1.9 Connecting NMEA 0183 Device

An NMEA 0183 device is connected to the CAN bus network via MFD unit or by using NMEA2000 Interface unit, IF-NMEA2K1.

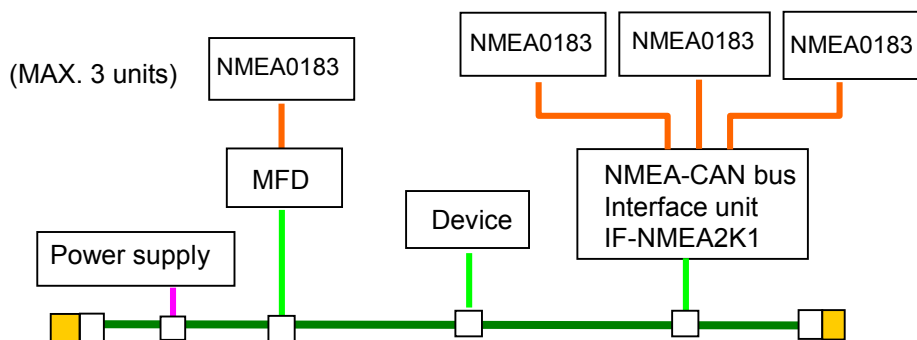

Fig.34 (a) Connection of NMEA0183 to CAN bus network with MFD and IF-NMEA2K1

The remote display RD-33 is also capable of converting the NMEA0183 signal to the CAN bus signal.

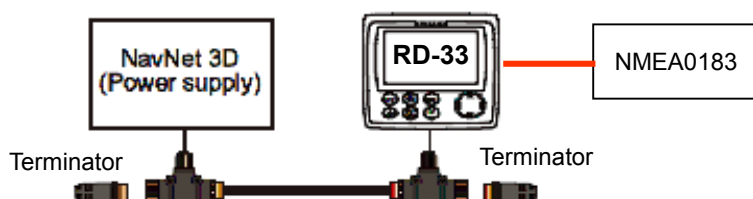

Fig.34 (b) Connection of NMEA0183 to CAN bus network with RD-33

## 1.10 CAN bus Network Limitations

When building a CAN bus network, keep in mind following limitations.

### 1.10.1 Single MFD in CAN bus network

Single MFD or DRS unit, one of MFD8, MFD12, MFD8B, and DRS is connected to a Furuno CAN bus network. Do NOT connect two or more MFD and/or DRS to the Furuno CAN bus network. The DRS and MFD units are connected each other via Ethernet.

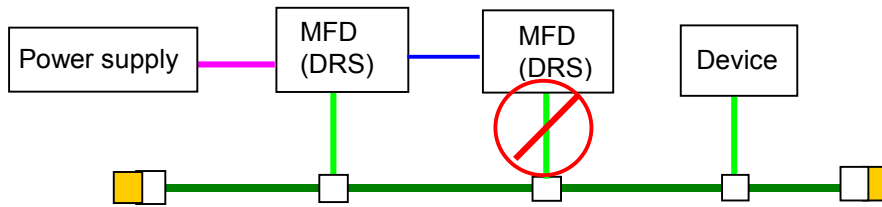

Fig.35 Single MFD or DRS in Furuno CAN bus network

### 1.10.2 Backbone Cable Length

#### Load Equivalency Number (LEN)

Like NMEA2000, the power rating of the Furuno CAN bus device is specified as a Load Equivalency Number, or LEN and used in planning network installations. One network load is defined as 50 mA or any portion thereof (e.g., a device taking 51 mA from the network power bus is a Two LEN device). A LEN of 4 means that the device consumes up to  $4 \times 50 \text{ mA} = 200 \text{ mA}$ .

Table 6 shows the LEN of Furuno CAN bus devices.

Table 6 LEN of Furuno CAN bus devices

Model	MFD BB	MFD 8/12	SC-30	GP-330B	WS-200	FI-50 series*
LEN	1	1	10	3	13	2

\*: FI-501/502/503/504/505/506

Use Tables 7 and 8 to find the maximum length of the backbone cable. First calculate the total LEN of the devices in the network. In the example of Fig.36, the total LEN is  $1 + 1 + 2 + 2 = 6$ . Then, find the maximum cable length for the LEN of 6 in Table 7 or 8: 150 meters for heavy cable and 50 meters for light cable when the network is powered from 15 Vdc power supply.

When the network is connected to 12 Vdc power supply, the maximum cable length is about half the value in Tables 7 and 8.

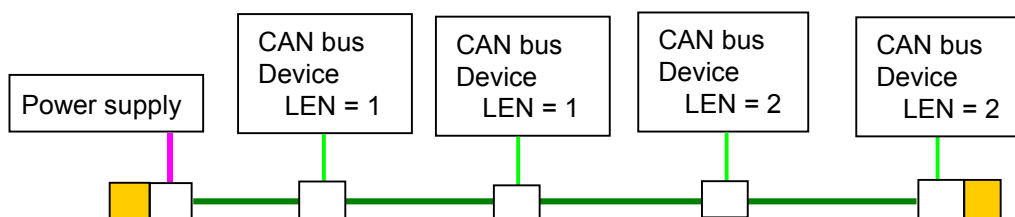

Fig.36

Practically, total LEN in the network is less than 20, so the overall cable length can be extended up to 150 m with heavy cables and 15 Vdc power supply.

When both heavy and light cables are used in the network as shown in Fig.10, the length of cable B is calculated by using the following formula.

$$B = (X - A) / 4$$

Where, X is the maximum cable length obtained from the table.

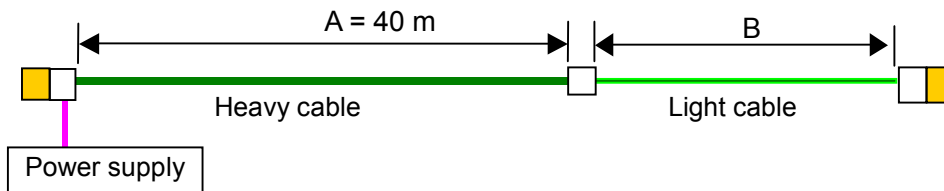

Fig.37

Assuming that the total LEN in the network is 50 and the heavy cable length, A is 40 m;

$$B = (80 \text{ m} - 40 \text{ m}) / 4 = 10 \text{ m}$$

When power supply is connected to the middle of the network as shown in Fig.38, the cable length of A and B is determined individually. For example, if the total LEN of devices attached to the cable A is 75, the maximum length of cable A is 50 m from Table 7. Do the same for B. The total length of cables A and B is less than 150 m.

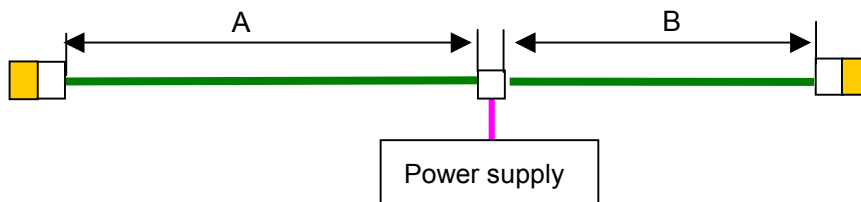

Fig.38 Middle-powered CAN bus network

When the power cable is connected to both ends of the network, the cable length is double the value obtained from the table. In any case, the cable length does not exceed 150 m. For example, the maximum cable length is 150 m, even if the calculated value is 180 m.

Note that power supplies are isolated and the shield connection is made at only one power supply (single-point ground) in multiple power supply configuration. Do NOT use a combination of battery and power supply connections.

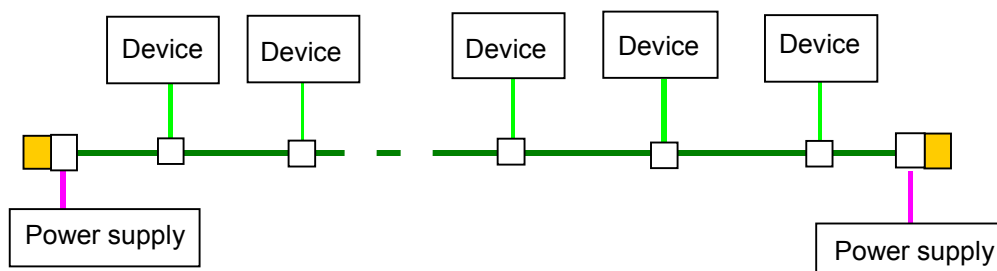

Fig.39 Multiple power supply configuration

### 1.10.3 Drop Cable Length

The total drop cable length must not exceed **60 m** and no single drop cable should exceed **6 m**.

### 1.10.4 Device Limitation

No more than 20 (LEN) CAN bus devices can be connected to the Furuno CAN bus network powered from the DRS and through the MFD unit.

The total LEN of the devices connected to the heavy backbone cable should not exceed 160 and 20 for the light backbone cable.

Table 7 Total LEN vs. Heavy backbone cable length (Power source: 15 Vdc \*)

Total LEN	Max. (m)	Total LEN	Max. (m)	Total LEN	Max. (m)	Total LEN	Max. (m)	Total LEN	Max. (m)
< 20	150	46	80	72	55	98	40	124	30
21	150	47	80	73	55	99	40	125	30
22	150	48	80	74	50	100	40	126	30
23	150	49	80	75	50	101	40	127	30
24	150	50	80	76	50	102	35	128	30
25	150	51	70	77	50	103	35	129	30
26	150	52	70	78	50	104	35	130	30
27	140	53	70	79	50	105	35	131	30
28	140	54	70	80	50	106	35	132	30
29	130	55	70	81	50	107	35	133	30
30	130	56	70	82	45	108	35	134	30
31	130	57	70	83	45	109	35	135	30
32	120	58	65	84	45	110	35	136	30
33	120	59	65	85	45	111	35	137	25
34	110	60	65	86	45	112	35	138	25
35	110	61	65	87	45	113	35	139	25
36	110	62	65	88	45	114	35	140	25
37	100	63	60	89	45	115	35	142	25
38	100	64	60	90	45	116	35	144	25
39	100	65	60	91	40	117	30	146	25
40	100	66	60	92	40	118	30	148	25
41	90	67	60	93	40	119	30	150	25
42	90	68	55	94	40	120	30	152	25
43	90	69	55	95	40	121	30	154	25
44	90	70	55	96	40	122	30	156	25
45	80	71	55	97	40	123	30	160	25

\*: When 12 Vdc power source is connected to the network, divide the cable length in halves.

Table 8 Total LEN vs. Light backbone cable length (Power source: 15 Vdc \*)

Total LEN	Max. (m)	Total LEN	Max. (m)	Total LEN	Max. (m)
<18	50	19	50	20	45

\*: When 12 Vdc power source is connected to the network, divide the cable length in halves.

## 1.11 Adding a New Device

A new device is added to a working network bus by using the following procedure. First, add an additional T-connector anywhere along the network backbone where a connection already exists. The connection is at the end of the network (between a T-connector and a terminator), between two T-connectors, between a T-connector and a backbone extension cable, or between two extension cables. Separate the connectors of the old connection and attach new T-connector between them. Then, connect the device to the T-connector by using a drop cable.

There are a few things to consider:

- 1) Voltage drop between the power source and the device located farthest from the power source is 3.0 Vdc or less when 12 Vdc battery is used.
- 2) Total network load must be considered. When the network is powered through the MFD and from the DRS, **total LEN is 20 or less.**
- 3) The network is terminated to function correctly.

## 1.12 Using Junction Box FI-5002

By using FI-5002 Junction Box, Furuno CAN bus is designed without T-connectors and terminators. The FI-5002 has 120-ohm terminal resistors, six terminal blocks for the connection of up to 6 devices, and two terminal blocks for the connection of backbone cables for network expansion. The junction box is not waterproof.

Fig.40 shows simplified schematic diagram of FI-5002. A three-way terminal block is used for the network power connection.

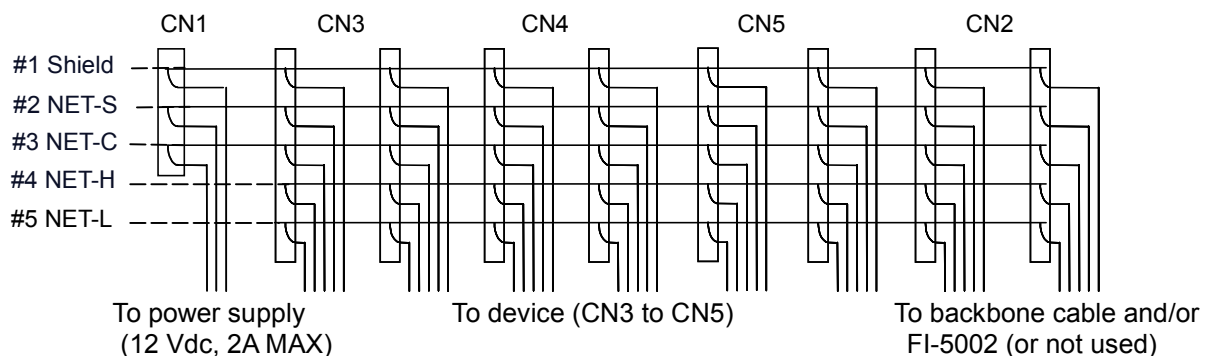

Fig.40 Connection of terminal blocks in FI-5002



Fig.41 shows a typical Furuno CAN bus network by using a junction box FI-5002.

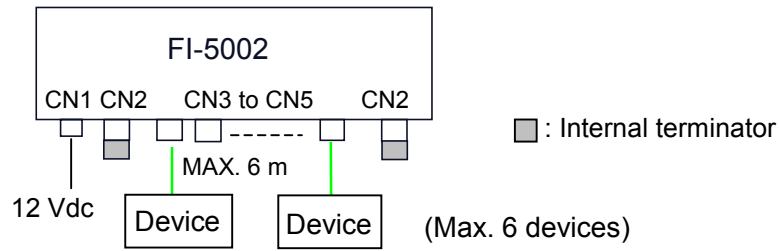

Fig.41 Typical connection on FI-5002

To connect the internal termination resistor to the end of the network bus, set the jumper block as below.

- 1) When no backbone cable is connected, R1 and R2 are set to ON position.
- 2) When one backbone cable is connected, either R1 or R2 is set to ON position.
- 3) When two backbone cables are connected, R1 and R2 are set to OFF position.

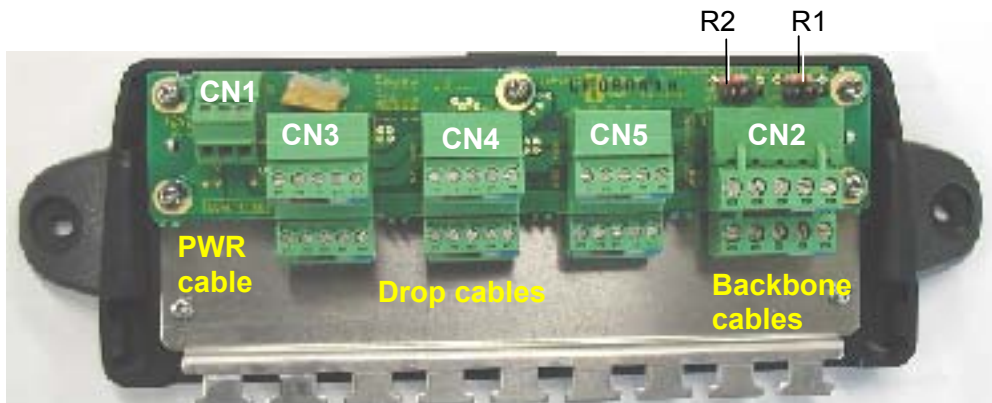
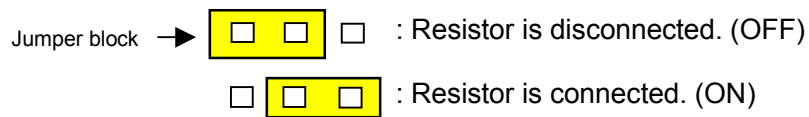

Fig.42 Internal terminators in FI-5002

The FI-5002 is added anywhere along the network backbone. A maximum of three FI-5002 is connected in series.

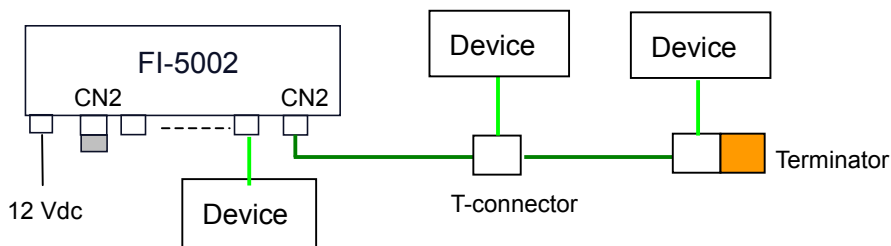

Fig.43 Network with FI-5002 and T-connector

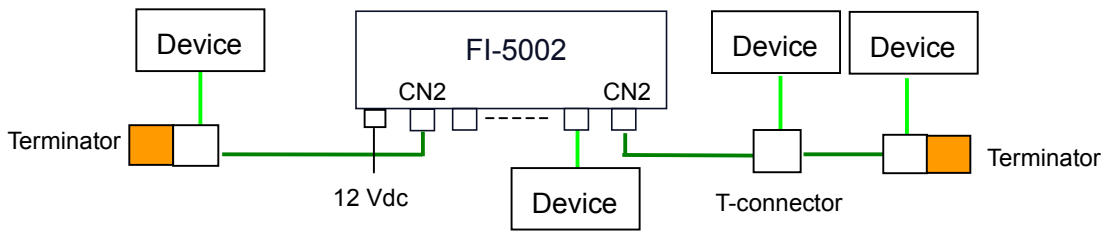

Fig.44 Network with two terminators connected to T-connectors

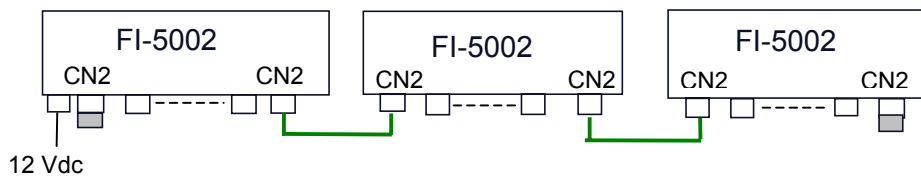

Fig.45 Three FI-5002 in network

### 1.13 NavNet Bridge

Two or more CAN bus networks can be connected by using MFD and DRS via Ethernet as shown in Fig.46. All devices share the sensor data in the network. The connection of the DRS having a CAN bus network to the MFD in the bridge eliminates the duplication of the cable run to the sensors outside.

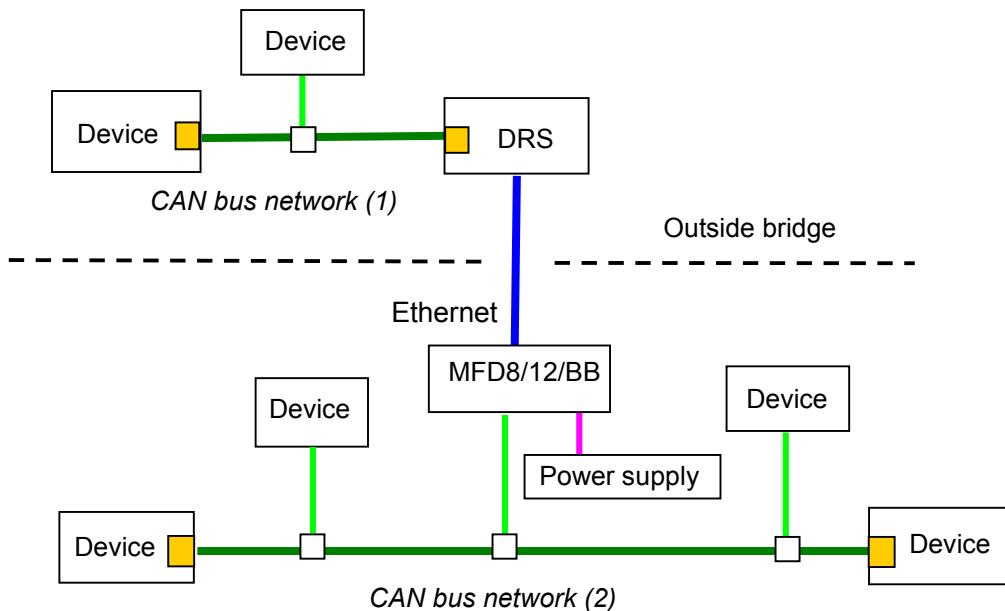

Fig.46 Simplified NavNet Bridge connecting two CAN bus networks

More complex networks are designed by using a network Hub, HUB-101 as shown in Fig.47.

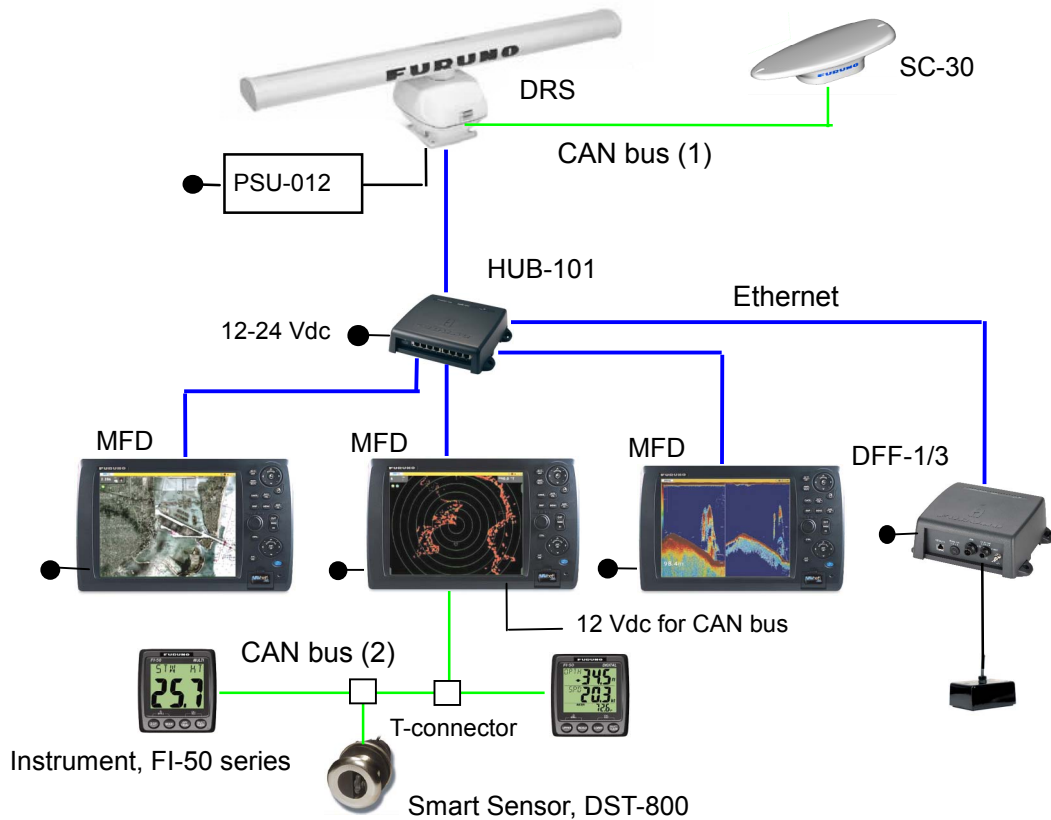

Fig.47 Two or more MFD in network

The number of devices that can be connected to the network is;

- DRS series: 2 units**
- HUB-101: 3 units**
- MFD8/12/BB: 10 units**
- RD-33: 3 units in CAN bus**

The MFDBB has a built-in 4-port Hub, so up to two HUB-101's are connected to the network with a MFDBB.

The Ethernet ports 1 and 2 are designed to output power to the control units, DCU12 and MCU-001. Do NOT connect MFD8/12 to ports 1 and 2, otherwise MFD8/12 in the earlier production may be damaged. MFD8/12 in the current production has the protection circuit.

See Fig.49.



Fig.48 MFDBB, rear view

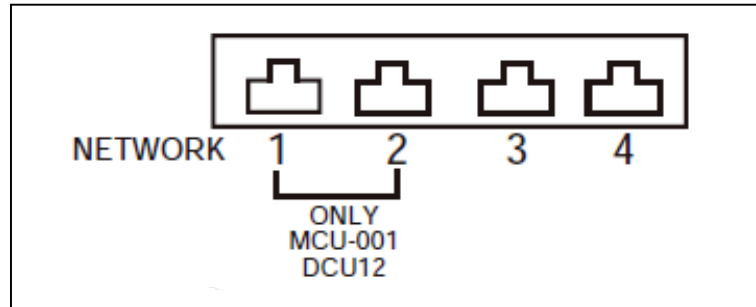

Fig.49 RJ45 jacks for Ethernet connection on MFDBB

Table 9 Pin assignment of built-in Hub of MFDBB

	NETWORK 1 & 2	NETWORK 3 & 4
#1	E_TD_P	E_TD_P
#2	E_TD_N	E_TD_N
#3	E_RD_P	E_RD_P
#4	SW_P	SW_P
#5	SW_N	SW_N
#6	E_RD_N	E_RD_N
#7	PWR_SW_N	N.C.
#8	PWR_SW_P	N.C.

Power Synchronization

Power on/off synchronization amongst all of the NavNet 3D display units can be achieved when the dedicated Ethernet hub HUB-101 is used. Set the corresponding DIP switch in the HUB-101 to ON position to activate this feature.

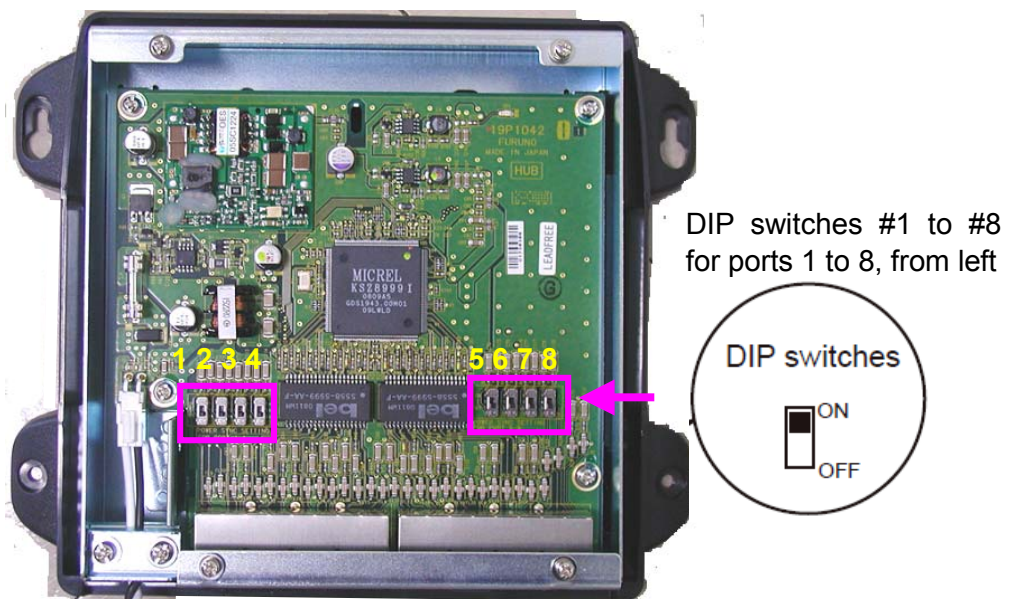

Fig.50 HUB-101 with cover removed