

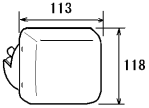
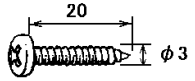
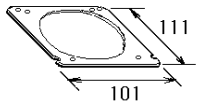
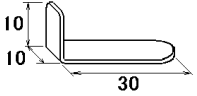

PACKING LIST FAP-7011-A

64BB-X-9860-1

1/1

NAME	OUTLINE	DESCRIPTION/CODE No.	Q'TY
ユニット UNIT			
操作部1D CONTROL UNIT 1D		FAP-7011-A/B 000-016-428-00	1
工事材料 INSTALLATION MATERIALS CP64-03010			
ナベタッピンネジ 1シ SELF-TAPPING SCREW		3X20 SUS304 000-163-884-10	4
Sマウントスポンジ SPONGE		26-001-1012-0 100-352-270-10	1
パネルリムーバー PANEL REMOVER		19-028-3124-1 100-340-471-10	1
バネ座金 SPRING WASHER		M3 SUS304 000-167-404-10	2
ミガキ丸平座金 FLAT WASHER		M3 SUS304 000-167-453-10	2
寸切ボルト BOLT		M3X40 SUS304 000-167-804-10	2
蝶ナット WING NUT		M3 SUS304 000-167-826-10	2

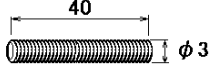
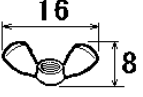
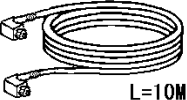
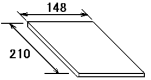
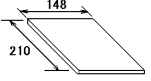
NAME	OUTLINE	DESCRIPTION/CODE No.	Q'TY
ケーブル組品 CABLE ASSEMBLY		BD-07AF-07AF-LR-100 001-081-200-10	1
図書 DOCUMENT			
取扱説明書(英) OPERATOR'S MANUAL (EN)		OME-72720-* 000-171-812-1*	1
操作要領書(多言) OPERATOR'S GUIDE (MLG)		MLG-72720-* 000-172-121-1*	1

(略図の寸法は、参考値です。DIMENSIONS IN DRAWING FOR REFERENCE ONLY.)

型式/コード番号が2段の場合、下段より上段に代わる過渡期品であり、どちらかが入っています。なお、品質は変わりません。

TWO TYPES AND CODES MAY BE LISTED FOR AN ITEM. THE LOWER PRODUCT MAY BE SHIPPED IN PLACE OF THE UPPER PRODUCT. QUALITY IS THE SAME.

C7273-Z02-A