

# Installation Manual FISH FINDER Model FCV-600/800

---

SAFETY INSTRUCTIONS .....	i
SYSTEM CONFIGURATIONS.....	iii
<b>1. MOUNTING.....</b>	<b>1</b>
1.1 Equipment List .....	1
1.2 Main Unit.....	3
1.3 Transducer (Option).....	8
<b>2. WIRING.....</b>	<b>20</b>
2.1 Wiring.....	20
2.2 Data Sentences/PGN Data Sentences .....	25
<b>3. INITIAL SETTINGS.....</b>	<b>28</b>
3.1 Language and Transducer Settings.....	28
3.2 Input/Output Settings .....	29
3.3 Wireless LAN setup .....	34
3.4 Calibration settings .....	39
3.5 Heave Sensor Settings .....	41
<b>APPX. 1 INSTALLATION FOR TRANSDUCER (THRU-HULL MOUNT).....</b>	<b>AP-1</b>
<b>APPX. 2 INSTALLATION OF 525STID-MSD .....</b>	<b>AP-5</b>
<b>PACKING LIST(S) .....</b>	<b>A-1</b>
<b>OUTLINE DRAWING(S) .....</b>	<b>D-1</b>
<b>INTERCONNECTION DIAGRAM(S) .....</b>	<b>S-1</b>

Link For Operator's Manual

Operator's Manual is available on FURUNO website. Access and download the manual from the QR code on the right.



**FURUNO ELECTRIC CO., LTD.**

[www.furuno.com](http://www.furuno.com)

All brand and product names are trademarks, registered trademarks or service marks of their respective holders.



# SAFETY INSTRUCTIONS

The operator and installer must read the applicable safety instructions before attempting to operate or install the equipment.



## WARNING

Indicates a condition that can cause death or serious injury if not avoided.



## CAUTION

Indicates a condition that can cause minor or moderate injury if not avoided.



Warning, Caution



Prohibitive Action



Mandatory Action

### Safety Instructions for the Installer



## WARNING



**Turn off the power at the switchboard before beginning the installation.**

Fire or electrical shock can result if the power is left on.



**Be sure no water leaks in at the transducer or sensor mounting location.**

Water leakage can sink the vessel. Also confirm that the transducer and/or sensor will not loosen by ship's vibration. The installer is solely responsible for the proper installation of the equipment. FURUNO will assume no responsibility for any damage associated with improper installation of the transducer.



**Use the specified power cable.**

Use of other power cable can cause fire.



## CAUTION



**Do not install the transducer or sensor where air bubbles and noise are present.**

Performance will be affected.



## CAUTION



**The following are guidelines for handling of the transducer cable.**

- Keep fuels and oils away from the cable.
- Locate cable in a safe place.
- Do not paint the cable.

The sheath of the cable is made of chloroprene rubber (or polychloride vinyl). For this reason do not paint the cable.



**Do not turn on the equipment with the transducer out of water.**













The transducer can be damaged.



**Observe the following compass safe distances to prevent interference to a magnetic compass:**

Model	Standard compass	Steering compass
FCV-600	0.40m	0.30m
FCV-800	0.70m	0.45m

## Safety Instructions for the Operator

 <b>WARNING</b>	 <b>CAUTION</b>
 <b>ELECTRICAL SHOCK HAZARD</b> Do not open the equipment.  Hazardous voltage exists inside the equipment. Refer repair to authorized service personnel.	 <b>Do not turn on the equipment with the transducer out of water.</b>  The transducer can be damaged.
 <b>Do not disassemble or modify the equipment.</b>  Fire, electrical shock or injury can result.	 <b>The picture is not refreshed when the picture advance setting is "Off".</b>  Maneuvering the vessel in this condition can result in a dangerous situation.
 <b>Immediately turn off the power at the switchboard if the equipment is emitting smoke or fire.</b>  Continued use of the equipment can cause fire or electrical shock. Contact a FURUNO agent for service.	 <b>Adjust the gain correctly.</b>  If the value of the gain setting is too small, weak signals will be suppressed and no indication appears. If the value is too large, noise will fill the screen and the indication will be difficult to distinguish. It is dangerous to use the depth display as a reference when operating the vessel without a clear indication of the seabed.
 <b>Do not maneuver the vessel based on the depth indication alone.</b>  Grounding can result	 <b>The LCD panel is made of glass. Handle it with care.</b>  Injury can result if the glass breaks.
 <b>Use the proper fuse.</b>  Use of an incorrect fuse can damage the equipment and can cause fire.	 <b>Do not use high-pressure cleaners to clean this equipment.</b>  This equipment has the waterproof rating outlined in the specifications, at the back of this manual. However, the use of high-pressure cleaning equipment can cause water ingress, resulting in damage to, or failure of, the equipment.

### Warning Label

A warning label is attached to the display unit. Do not remove the label. If the label is missing or damaged, contact a FURUNO agent or dealer about replacement.



Name: Warning Label  
Type: 16-021-3517-0  
Code No.: 100-350-230-10

The TFT LCD is constructed using the latest LCD techniques, and displays 99.99% of its pixels. The remaining 0.01% of the pixels may drop out or blink, however this is not an indication of malfunction.

### User Guide

On the next page, there is a simplified manual (User Guide) that explains only the basic operations. You can download the manual (in color) in PDF format from our official website.





# SYSTEM CONFIGURATIONS

**Note 1:** See "Equipment List" on page 1 for compatible transducers.

## FCV-600

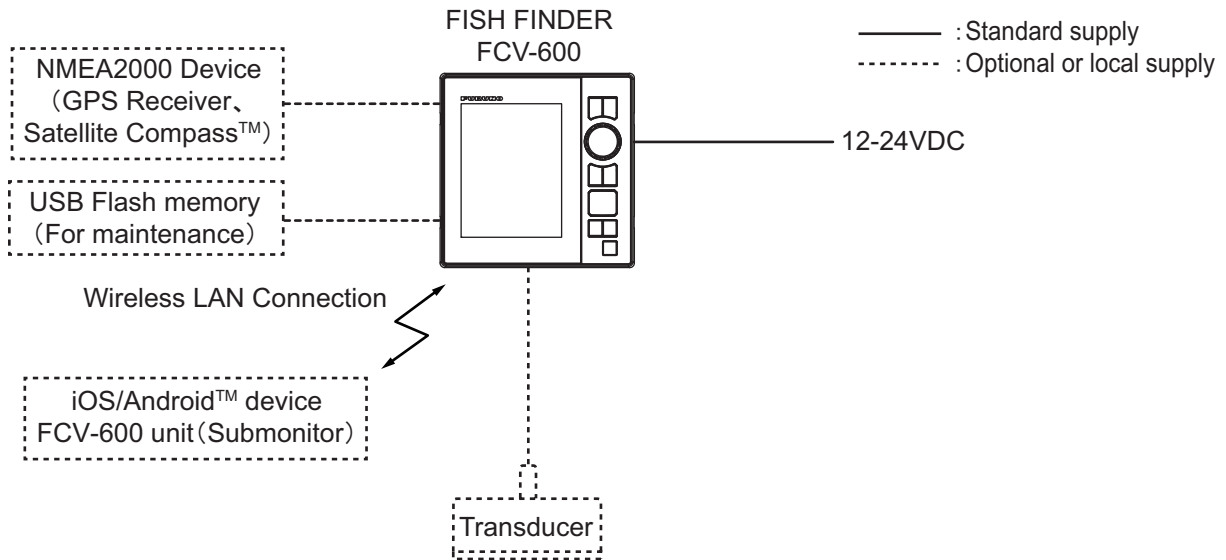

## FCV-800

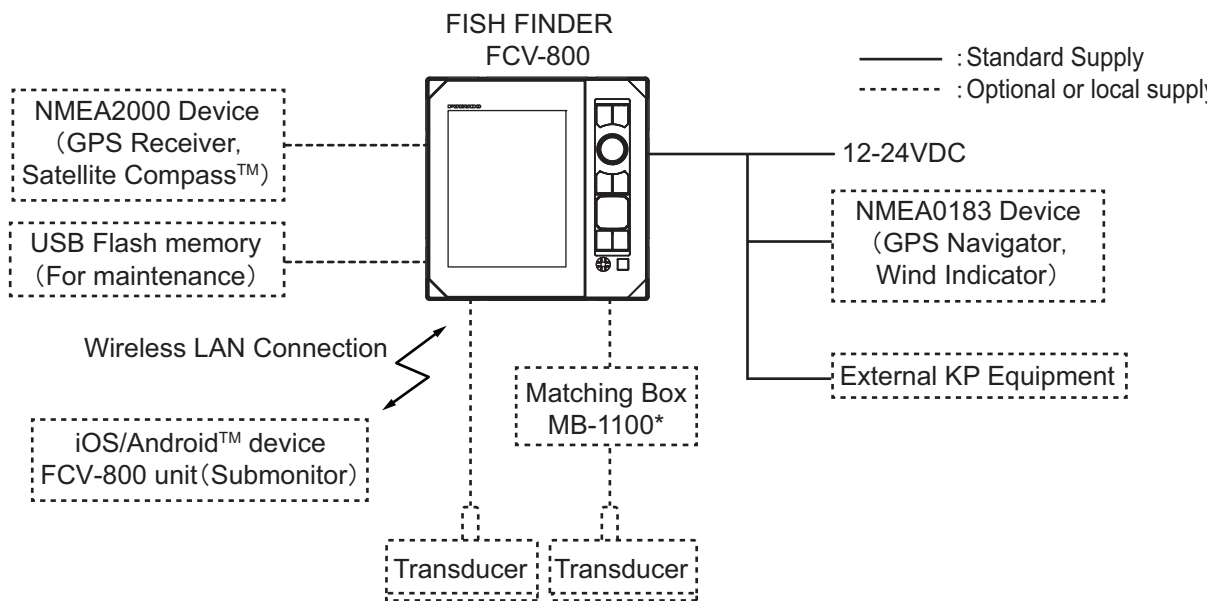

\*: Required when 200B-5S, 50B-6, 50B-6B or 50/200-1T is connected only.

**Note 2:** The optional cable assembly (type: FRU-MJ10CCB12-300) is required for B265LH-FJ12/ TM265LH-FJ12/ CM265LH-FJ12 transducers (FCV-800 only).

# 1. MOUNTING

## NOTICE

**Do not apply paint, anti-corrosive sealant or contact spray to coating or plastic parts of the equipment.**

Those items contain organic solvents that can damage coating and plastic parts, especially plastic connectors.

## 1.1 Equipment List

### Standard supply

Name	Type	Code No.	Qty	Remarks	
FISH FINDER	FCV-600	-	1	With hard cover	
	FCV-800	-			
Installation Materials	CP02-10001	-	1	For power/ data cables, screws	For FCV-600
	CP02-10101	-			For FCV-800
Accessories	FP03-11601	-	1	Cleaner (cloth)	For both FCV-600/800
Spare Parts	SP02-07001	-	1	Fuse	

### Optional supply

Name	Type	Code No.	Remarks	
Operator's Manual	OMJ-23940-*	000-199-649-1*	Japanese edition	
	OME-23940-*	000-199-650-1*	English edition	
Inside Hull Kit S	22S0191	-	With installation instructions; not available with bottom discrimination display.	
Extension Cable	C332 10M	001-464-120	10m, for transducer (10pin)	
Cable Assembly	FRU-CCB12-DA-10M	001-608-450	10m, for transducer (12pin)	
	FRU-MJ10CCB12-300	001-636-150	Converter Cable (10pin×2 - 12pin), 0.3m, for dual frequency CHIRP transducer, for FCV-800	
	FRU-CF-H07-02M	001-641-070	2m, for FCV-600	
	FRU-CF-H16-02M	001-641-080	2m, for FCV-800	
NMEA Cable Assembly	FRU-NMEA-PMMFF-010	001-533-060	1m	For NMEA2000 device
	FRU-NMEA-PMMFF-020	001-533-070	2m	
	FRU-NMEA-PMMFF-060	001-533-080	6m	
	FRU-NMEA-PFF-010	001-507-010	1m	
	FRU-NMEA-PFF-020	001-507-030	2m	
	FRU-NMEA-PFF-060	001-507-040	6m	
NMEA Connector	FRU-MM1MF1MF1001	001-507-050	T Connector	
	FRU-MM1000000001	001-507-070	Terminator	
	FRU-MF000000001	001-507-060	Terminator	

Name	Type	Code No.	Remarks
Matching Box	MB-1100	-	For CW 1kW transducers, For FCV-800
Flush Mount Kit	OP02-89	001-638-230	For FCV-600
	OP02-88	001-638-240	For FCV-800
Transducer	520-5PSD* <sup>1</sup>	-	600W transducers
	520-5MSD* <sup>1</sup>	-	
	520-PLD* <sup>1</sup>	-	
	525-5PWD* <sup>1</sup>	-	
Transducer	525T-PWD* <sup>1</sup>	-	600W transducers
	525T-BSD* <sup>1</sup>	-	
	525T-LTD/12* <sup>1</sup>	-	
	525T-LTD/20* <sup>1</sup>	-	
	SS60-SLTD/12* <sup>1</sup>	-	
	SS60-SLTD/20* <sup>1</sup>	-	
Transducer (Speed/Temperature Sensor)	525STID-PWD* <sup>1</sup>	-	
	525STID-MSD* <sup>1</sup>	-	
CHIRP Transducer	TM150M	-	300W, for single frequency CHIRP transducers
	B-75L	-	
	B-75H	-	600W, for single frequency CHIRP transducers
Transducer	200B-5S*10M* <sup>3</sup>	-	For 1kW transducers (FCV-800 only)
	50B-6*10M* <sup>3</sup>	-	
	50B-6B*15M* <sup>3</sup>	-	
	50/200-1T*10M* <sup>1</sup>	-	
	526TID-HDD* <sup>1</sup>	-	
CHIRP Transducer	B265LH-FJ12* <sup>2</sup>	-	1kW, for dual frequency CHIRP transducers (FCV-800 only)
	TM265LH-FJ12* <sup>2</sup>	-	
	CM265LH-FJ12* <sup>2</sup>	-	
	B-175L	-	1kW, for single frequency CHIRP transducers (FCV-800 only)
	B-175H	-	

\*1: Compatible with ACCUFISH™, Bottom discrimination, RezBoost™, Bottom Hardness.

\*2: Compatible with ACCUFISH™.

\*3: Compatible with Bottom Hardness.

## 1. MOUNTING

### Other compatible transducers (local supply)

The transducers (Manufactured by AIRMAR Technology Corporation) listed in the table below are compatible with this equipment.

#### Single Frequency CHIRP

Output Power	Type						
300W	B150M	SS75L	P95M				
600W	B75M	SS75M	B785M	SS75H	TM165HW	P75M	B75HW
1kw (FCV-800 only)	B175M	TM185M	B285M	B175HW	TM185HW	B285HW	

#### Dual Frequency CHIRP (FCV-800 only)

Output Power	Type					
300W/600W	B765LM	B765LH				
1kw	B265LM	TM265LM	CM265LM	B275LHW	TM275LHW	CM275LHW

## 1.2 Main Unit

This unit can be mounted on a desktop, bulkhead or flush mounted in a console.

#### Mounting considerations

When choosing a location keep the following in mind:

- Do not overhead mount the unit.
- Select a location where the unit is easy to operate.
- Be sure to follow the recommended maintenance space show in the outline drawing.
- Locate the unit away from the air from air conditioners.
- The operating temperature range is 5°F to 131°F.
- Locate the unit away from devices that emit active gas.
- The mounting location must be well ventilated.
- Select a location where vibration and shock are minimal.
- A magnetic compass will be affected if the main unit is placed too close to the compass. Observe the compass safe distances in the safety instructions (see page i) to prevent interference to the compass.
- Select a location out of direct sunlight. Prolonged exposure to direct sunlight can cause LCD blackout.
- When installing the sub monitor, select a location where wireless LAN icon (at least two bars) is shown in the upper right corner of the sub monitor's display.

## 1.2.1 Desktop and bulkhead mount

This unit is shipped with a hanger. Follow the steps below to mount the main unit on a desktop or bulkhead. The figures of FCV-800 are used in this section.

1. Unfasten the knobs on either side of the main unit and detach the unit from the hanger.

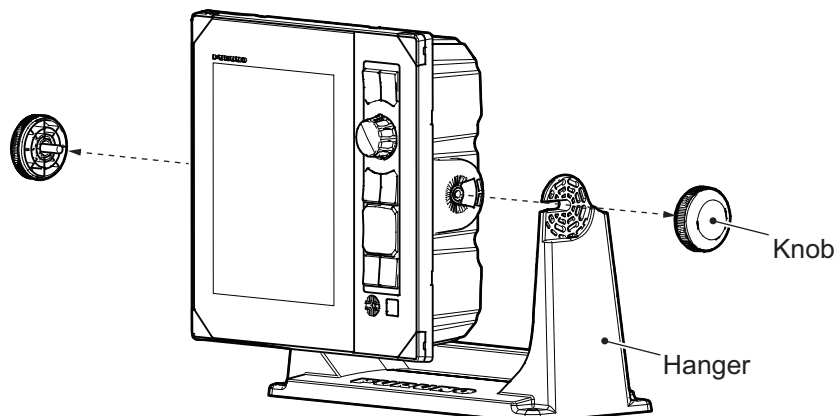

2. Drill four holes for the self-tapping screws at the mounting location. Be sure to follow the recommended maintenance space shown in the outline drawing. Insufficient space may cause damage to connectors when disconnecting and reconnecting them.
3. Fix the hanger to the mounting location with four self-tapping screws ( $\phi 5 \times 20$ , supplied). The hanger should be oriented with the insertion slots facing forward.

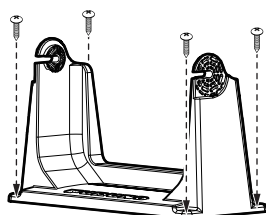

Desktop mount

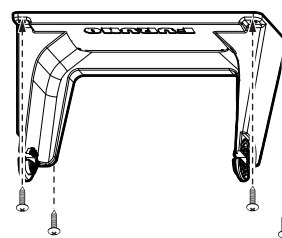

Bulkhead mount

4. See section 2.1 to attach cables to the back of the main unit.  
**Note:** Work on a soft cloth to avoid damaging the unit.
5. Fit the main unit to the hanger and tighten the bolts on either side evenly. Adjust the angle of the main unit so that the screen can be viewed clearly.

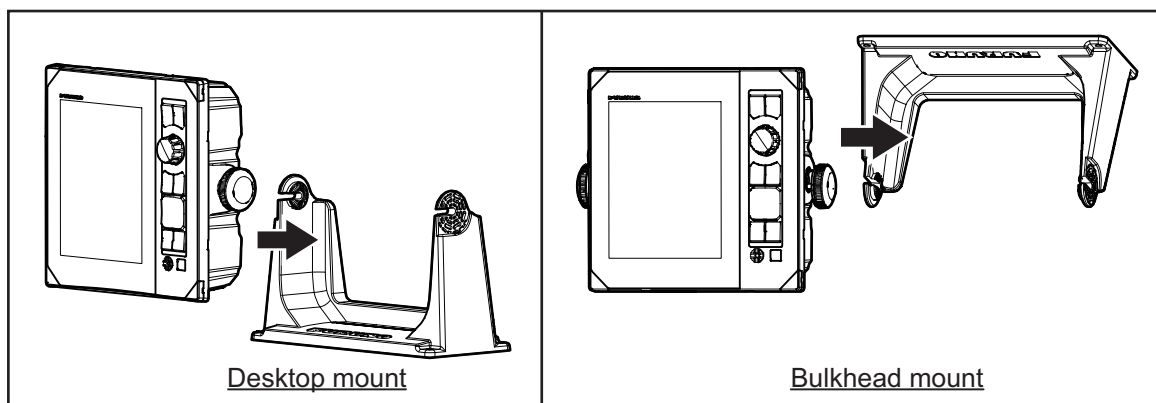

6. Attach the hard cover to the main unit for LCD protection.

## 1. MOUNTING

### 1.2.2 Flush mount (option)

Use the optional flush mount kit to install the unit as shown below.

**Note 1:** Select a flat mounting location to install the unit.

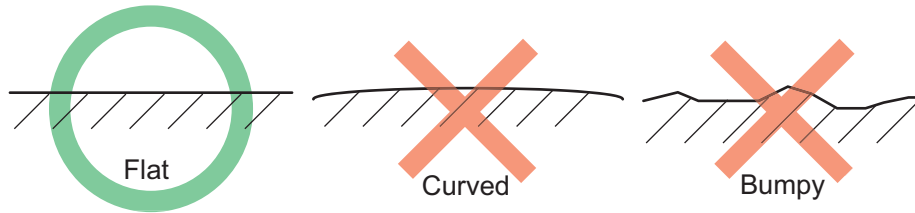

**Note 2:** It is recommended to set up a dedicated breaker when flush mounting the unit, since it will be difficult to disconnect cables.

#### **For FCV-600**

The below flush mount kit is required when flush mounting the unit.

*Kit details: OP02-89, Code No.: 001-638-230*

Name	Qty
Mounting template (for both FCV-600 and FCV-800 (double-sided printing))	1
Sponge V for F mount	2
Sponge H for F mount	2
F mount metal assembly	2
Slotted Hex Bolt	2

1. Use the template (supplied) and cut out a hole in the mounting location.
2. See page 4 to unfasten the two knobs on either side of the main unit to separate the main unit and a hanger. The knob and hanger can be disposed.
3. Attach the Sponge V and H for Mount F (four in total, supplied) in order at the back of the unit (see the figure below).

**Note 1:** Work on a soft cloth to avoid damaging the main unit.

**Note 2:** Make sure not leave any gap between sponge V and H when attaching.

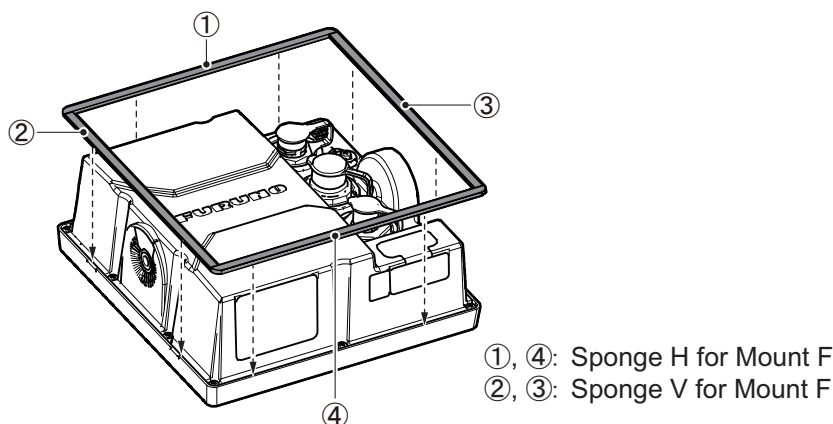

4. See section 2.1 to connect the required cables to the back of the unit.
5. Fasten the main unit with connected cables to the mounting location.



- Rotate the butterfly bolts and butterfly nuts attached to the flush mount F metal (two in total) to move the screw leg protector towards the mount F metal.

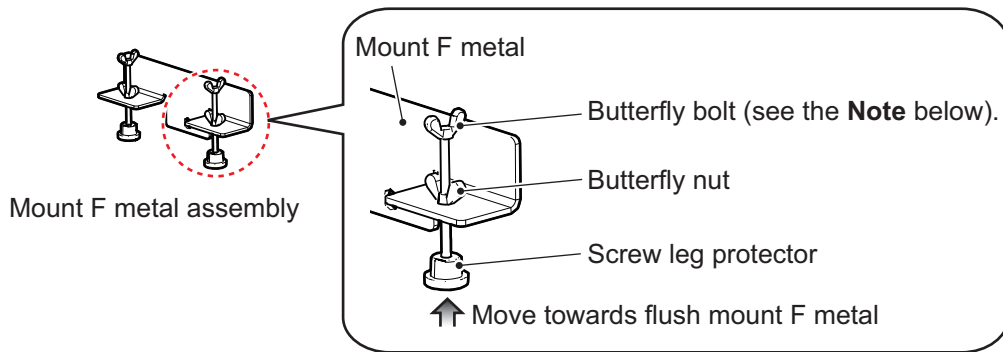

**Note:** Tighten the butterfly bolts by hand without using tools. When tightening the bolts, tighten the all four bolts evenly and gradually. Tools can be used for tightening the butterfly nuts.

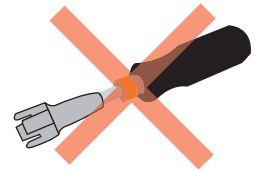

- Use both slotted hex bolts (M6×12, supplied) and fasten mount F metal assembly to the both sides of the main unit. F Mount metal assembly should be attached to the hanger mounting screw holes on both sides of the main unit.

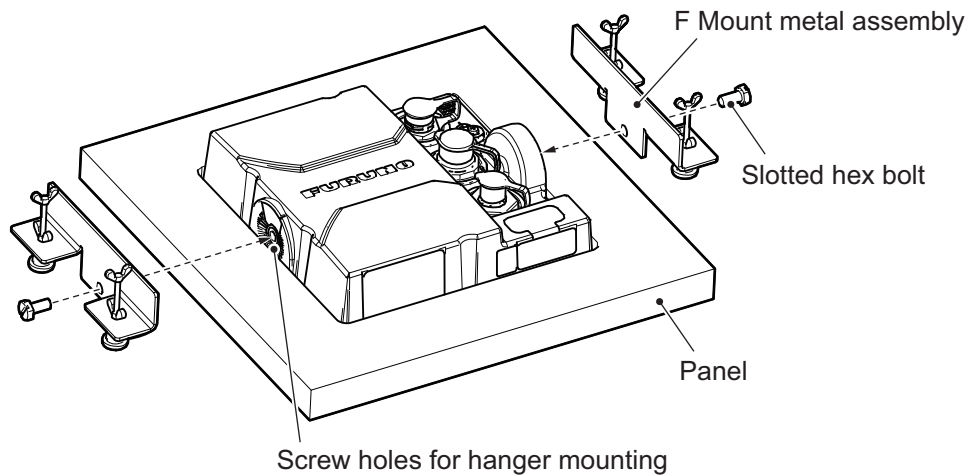

- Rotate the butterfly bolts of the mount F metal to fasten the screw leg protector to the panel.
- Fasten the butterfly nuts of the mount F metal.

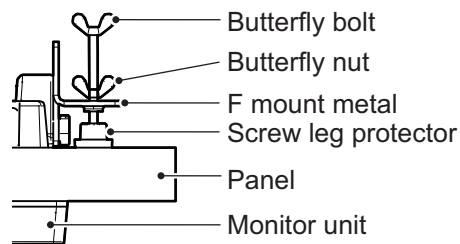

- Attach the hard cover to the unit for LCD protection.

## 1. MOUNTING

### **For FCV-800**

The below flush mount kit is required when flush mounting the main unit.

*Kit details: OP02-88. Code No.: 001-638-240*

Name	Qty
Mounting template (for both FCV-600 and FCV-800 (double-sided printing))	1
Sponge V for F mount	2
Sponge H for F mount	2
Binding screw	4

1. Use the template (supplied) and cut out a hole in the mounting location.
2. Drill four holes for the binding screws at the mounting location.
3. See page 4 to unfasten the two knobs on either side of the main unit to separate the main unit and a hanger. The knobs and hanger can be disposed.
4. Attach the Sponge V and H for Mount F (four in total, supplied) in order at the back of the main unit (see the figure below).

**Note 1:** Work on a soft cloth to avoid damaging the unit.

**Note 2:** Attach the sponge so that it does not block the screw holes.

**Note 3:** Make sure not leave any gap between sponge V and H when attaching.

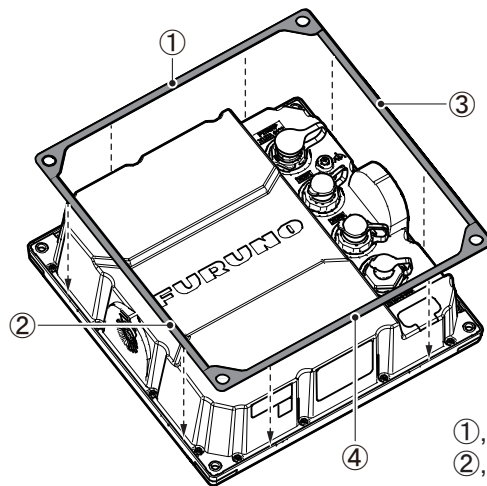

①, ④: Sponge H for Mount F  
②, ③: Sponge V for Mount F

5. See section 2.1 to connect the required cables to the back of the main unit.
6. Fasten the main unit with connected cables to the mounting location.
7. Remove the four screw covers on the each corner of the main unit.

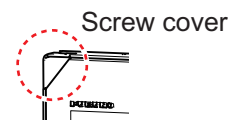

8. Use the four binding screws ( $\phi 5 \times 20$ ) and fasten the main unit.

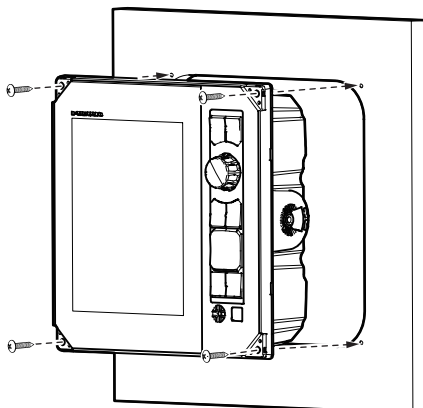

9. Place the screw covers back to the each corner of the unit. Push the screw covers in order until they click into their place, first on the front and then on the sides (two locations). There is no "click" when fitting the side covers.
10. Attach the hard cover to the main unit for LCD protection.

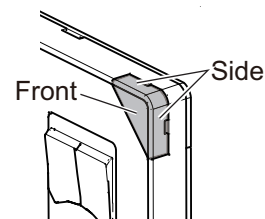

### 1.3 Transducer (Option)

**⚠ NOTICE**

**⊘ Do not cover the transducer with FRP resin.**  
 The heat generated when the resin hardens may damage the transducer, especially CHIRP transducer.

The transducer can be installed through the ship's hull, stern or inboard. The method is selected according to the ship's shape and other factors.

**Note:** The transducer must be equipped in an external tank (compatible with: CM265LH-FJ12/CM265LM/ CM275LHW). Do not install the transducer in fibreglass or inside the hull. Use a tank that allows the surface and sides of the transducer to be immersed in water. If possible, use and install the transducer with tank listed in the table below.

Type	Name	Code No.
T-711-FJ12	Hull Tank (R2)	000-038-527

# 1. MOUNTING

## 1.3.1 Thru-hull mount

### **520-PLD**

For details of the installation, see the transducer manual.

### **Transducer mounting location (for 520-5PSD/520-5MSD)**

The thru-hull mount transducer provides the best performance of all, since the transducer protrudes from the hull and the effect of air bubbles and turbulence near the hull skin is reduced. When the boat has a keel, the transducer should be at least 30 cm away from it.

The performance of this fish finder is directly related to the mounting location of the transducer, especially for high-speed cruising. The installation should be planned in advance, keeping the length of the transducer cable and the following factors in mind:

- Air bubbles and turbulence caused by movement of the boat seriously degrade the sounding capability of the transducer. The transducer should, therefore, be located in a position where water flow is the smoothest.
- Noise from the propellers adversely affects performance and the transducer should not be mounted nearby. The lifting strakes are notorious for creating acoustic noise, and these must be avoided by keeping the transducer inboard of them.
- The transducer must always remain submerged, even when the boat is rolling, pitching or up on a plane at high speed.

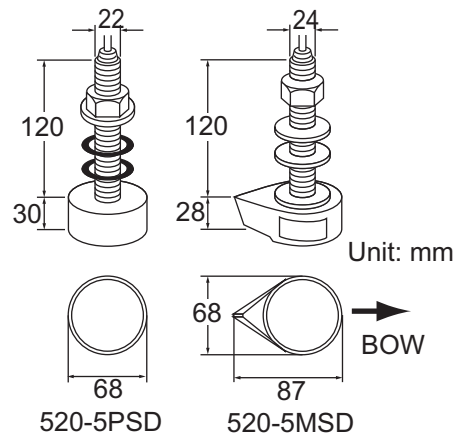

- A practical choice would be somewhere between 1/3 and 1/2 of the boat's length from the stern. For planing hulls, a practical location is generally rather far astern, so that the transducer is always in water regardless of the planing attitude.

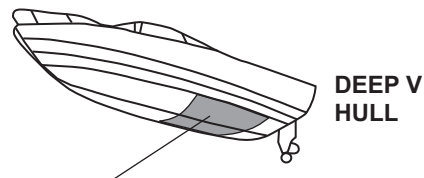

- Position 1/2 to 1/3 of the hull from stern.
- 15 to 30 cm off center line (inside first lifting strakes.)

### **Procedure for installation of the thru-hull mount transducer (for 520-5PSD/520-5MSD)**

1. With the boat hauled out of the water, mark the location chosen for mounting the transducer on the bottom of the hull.
2. If the hull is not level within 15° in any direction, fairing blocks made out of teak should be used between the transducer and hull, both inside and outside, to keep the transducer face parallel with the water line. Fabricate the fairing block as shown in the following figure and make the entire surface as smooth as possible to provide an undis-



- Within the wetted bottom area
- Deadrise angle within 15°

turbed flow of water around the transducer. The fairing block should be smaller than the transducer itself to provide a channel to divert turbulent water around the sides of the transducer rather than over its face.

3. Drill a hole just large enough to pass the threaded stuffing tube of the transducer through the hull, making sure it is drilled vertically.
4. Apply a sufficient amount of high quality caulking compound to the top surface of the transducer, around the threads of the stuffing tube and inside the mounting hole (and fairing blocks if used) to ensure watertight mounting.
5. Mount the transducer and fairing blocks and tighten the locknut. Be sure that the transducer is properly oriented and its working face is parallel to the waterline.

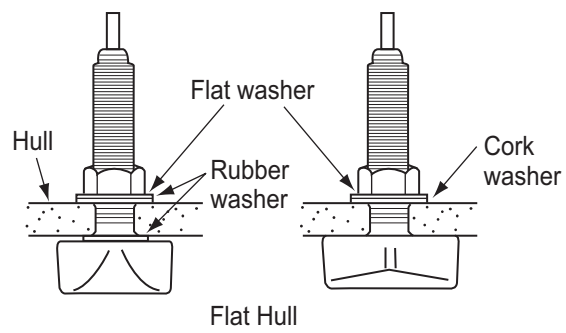
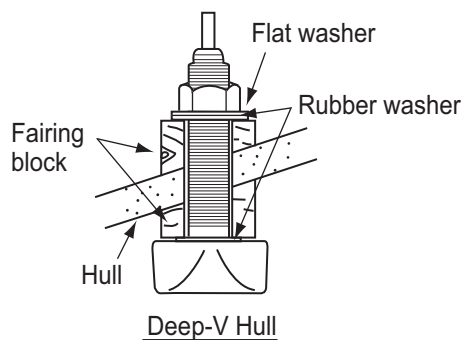
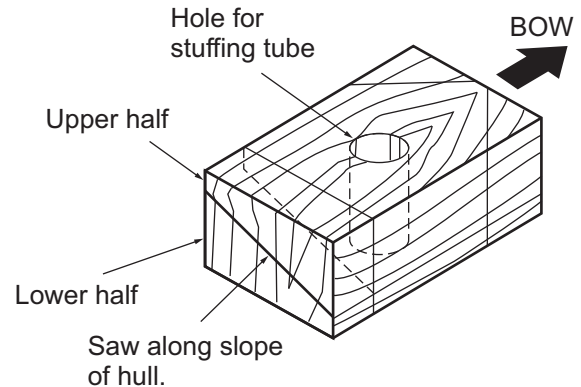

**Note:** Do not over-stress the stuffing tube and locknut through excessive tightening, since the wood block will swell when the boat is placed in the water. It is suggested that the nut be tightened lightly at installation and retightened several days after the boat has been launched.

#### **Transducer preparation (for 520-5PSD/520-5MSD)**

Before putting the boat in water, wipe the face of the transducer thoroughly with a detergent liquid soap. This will lessen the time necessary for the transducer to have good contact with the water. Otherwise the time required for complete "saturation" will be lengthened and performance will be reduced.

**Note: DO NOT** paint the transducer. Performance will be affected.

## 1. MOUNTING

### 1.3.2 Transom mount transducer

The optional transom mount transducer is very commonly employed, usually on relatively small I/O or outboard boats. Do not use this method on an inboard motor boat because turbulence is created by the propeller ahead of the transducer.

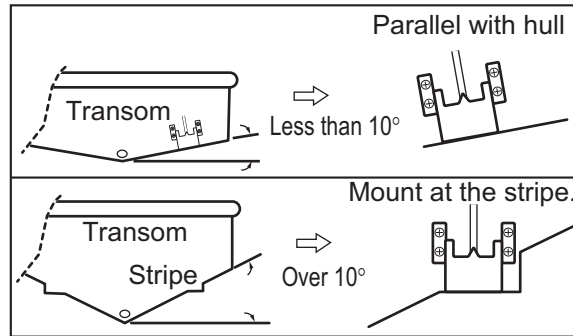

*525-5PWD mounting locations*

#### **Installation procedure**

A suitable mounting location is at least 50 cm away from the engine and where the water flow is smooth.

1. Drill four pilot holes for self-tapping screw ( $\phi 5 \times 20$ ) in the mounting location.
2. Coat the threads of the self-tapping screws ( $M5 \times 14$ ) for the transducer with marine sealant for waterproofing. Attach the transducer to the mounting location with the self-tapping screws.

**Note:** DO NOT overtighten screws; they may be damaged.

3. Adjust the transducer position so the transducer faces right to the bottom. If necessary, to improve water flow and minimize air bubbles staying on the transducer face, incline the transducer about  $5^\circ$  at the rear. This may require a certain amount of experimentation for fine tuning at high cruising speeds.
4. Tape the location shown in the figure below. Fill the gap between the wedge front of the transducer and transom with epoxy material to eliminate any air spaces.

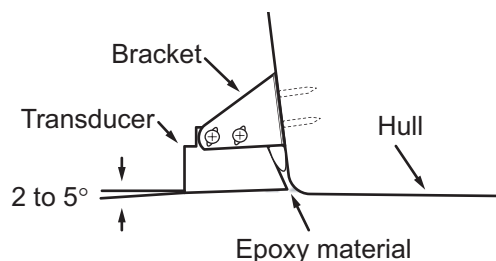
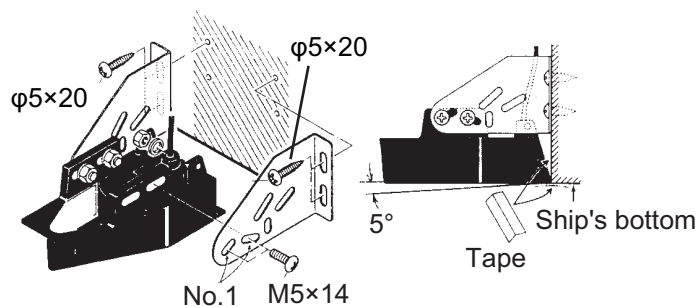

5. After the epoxy hardens, remove the tape.



### 1.3.3 How to mount a Thru-hull transducer inside the hull

The thru-hull mount transducer may also be installed inside the hull on FRP boats. However, this installation method affects the ability to detect the bottom, fish and other objects because the ultrasound pulse is weakened when it passes through the hull. Do not install the transducer inside the hull on a steel or wooden hull vessel, since the ultrasound pulse cannot penetrate those hulls.

## NOTICE

This mounting method should not be used to mount the transducer that supports the ACCU-FISH™, the bottom discrimination display or the [Enhanced] RezBoost™ functions since performance is greatly degraded.

### Necessary tools

You will need the following tools:

- Sandpaper (#100)
- Adhesive (Marine sealant)
- Water-filled plastic bag

### Remarks on installation

- Do the installation with the ship moored at a dock, etc. The water depth should be 6.5-32 feet (2-10 meters).
- Install the transducer within the engine room.
- Turn off the engine.
- Do not power the unit with the transducer in the air, to prevent damage to the transducer.
- Do not use this method on a double layer hull.

### Installation location

If the thickness of the hull varies, then the attenuation of the ultrasound pulse may vary. Select a location where the attenuation is the lowest.

1. Select two or three locations considering the four points mentioned below. (You will finalize the mounting location through some trial and error later.)
  - Mount the transducer at a location  $1/2$  to  $1/3$  of the length of the boat from the stern.
  - The mounting location is between 15 to 50 cm from the centerline of the hull.
  - Do not place the transducer over hull struts or ribs which run under the hull.
  - Avoid a location where the rising angle of the hull exceeds  $15^\circ$ , to minimize the effect of the boat's rolling.

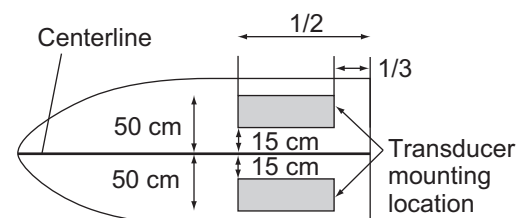

## 1. MOUNTING

2. Decide the most suitable site from the selected locations by doing the following:
  - 1) Refer to section 2.1 for connecting the power cable and transducer cable to the main unit.
  - 2) Put the transducer into a water-filled plastic bag. Press the transducer against the chosen site.

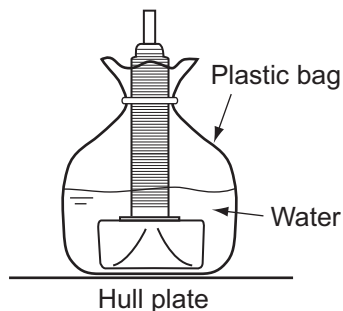

- 3) Press the  /BRILL key to turn on the main unit.
  - 4) See section 3.1 and select the desired transducer model.
  - 5) Press the **MENU/ESC** key to open the main menu.
  - 6) Select [Sounder] and press the **KNOB**.
  - 7) Select [TX Power] and press the **KNOB**.
  - 8) Select [1] and press the **KNOB**.
  - 9) Press the **MENU/ESC** key twice to close the menu.
  - 10) Check if the bottom echo appears on the display. If it doesn't, do this procedure until a suitable location is found.
  - 11) After the mounting location is decided, turn off the power of the unit.
3. Remove the transducer from the plastic bag and wipe the face of transducer with a cloth to remove water and any foreign material. Lightly roughen the face of transducer with #100 sandpaper. Also, use the sandpaper to roughen the inside of the hull where the transducer is to be mounted.
  4. Wipe off any sandpaper dust from the face of the transducer.
  5. Dry the face of the transducer and the hull. Coat the transducer face and mounting location with marine sealant. Hardening begins in approx. 15-20 minutes so do this step without delay.

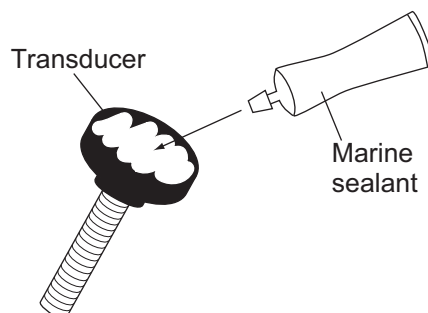

6. Attach the transducer to the hull.  
Press the transducer firmly down on the hull and gently twist it back and forth to remove any air which may be trapped in the marine sealant.

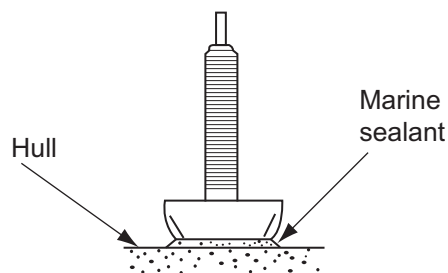

7. Support the transducer with a piece of wood to keep it in place while the sealant is drying. It takes 24-72 hours to harden completely.
8. Turn the power on and change the menu setting as follows:
- 1) Press the **MENU/ESC** key to show the main menu.
  - 2) Select [Sounder] menu and press the **KNOB**.
  - 3) Select [TX Power] and press the **KNOB**.
  - 4) Select [5] and press the **KNOB**.
  - 5) Press the **MENU/ESC** key.
  - 6) Select [Calib] from the [System] menu and press the **KNOB**.
  - 7) Select the [Gain ADJ CHIRP HF/MF/LF], [Gain ADJ CW HF/ LF] as desired and press the **KNOB**. Menu items are displayed according to the connected transducer.
  - 8) Set the value as "+20" and press the **KNOB**.
  - 9) If multiple CW/CHIRP transducers are shown, repeat step 7.
  - 10) For FCV-600, select [Bottom Level XDR] and press the **KNOB**. For FCV-800, select [Bottom Level XDR1] and press the **KNOB**.
  - 11) Set the bottom level value as "-40" and press the **KNOB**.
  - 12) If two transducers are connected, repeat step 10 and select [Bottom Level XDR2] to set the value (for FCV-800 only).
  - 13) Press the **MENU/ESC** key two times to close the menu.

## 1. MOUNTING

### 1.3.4 Mounting of 525STID-MSD/525STID-PWD transducers (speed/temperature sensors)

**Note:** DO NOT overtighten screws. They may be damaged.

#### **525STID-MSD**

The optional transducer 525STID-MSD is designed for thru-hull mounting. For mounting, see section 1.3.1.

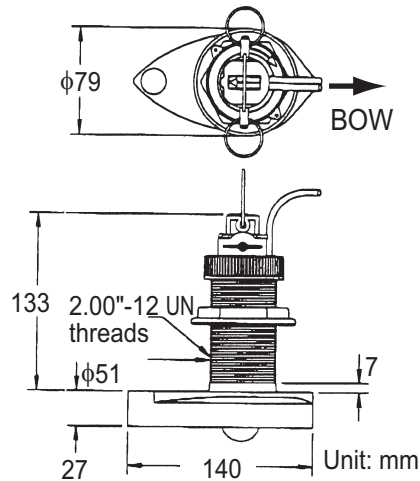

*Triducer 525STID-MSD*

#### **525STID-PWD**

The optional transom mount transducer 525STID-PWD can be mounted by the thru-hull method or the inside-hull method.

#### **Tools and materials needed**

- Scissors
- Safety goggles
- Electric drill
- Drill bit:  $\phi 3, \phi 4, \phi 6, \phi 9$
- Straight edge
- Pencil
- Water-based antifouling paint (mandatory in salt water)
- Masking tape
- Dust mask
- Screwdrivers
- Marine sealant
- Cable ties

#### **Mounting location**

To ensure the best performance, the sensor must be submerged in aeration-free and turbulence-free water. Mount the sensor close to the centerline of the boat. On slower heavier displacement hulls, positioning it farther from the centerline is acceptable. Allow adequate space above the bracket for it to release and rotate the sensor upward. Refer to the illustration below for dimensions.

Height without speed sensor  
191 mm (7-1/2")

Height with speed sensor  
213 mm (8-1/2")

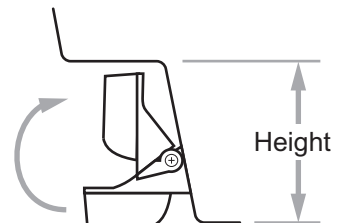

## NOTICE

**Do not mount the sensor in an area of turbulence or bubbles:**

- near water intake or discharge openings
- behind strakes, struts, fittings, or hull irregularities
- behind eroding paint (an indication of turbulence).

**Avoid mounting the sensor where the boat may be supported during trailering, launching, hauling, and storage.**

**Note 1: For single drive boat**, mount on the starboard side at least 75 mm (3") beyond the swing radius of the propeller.

**Note 2: For twin drive boat**, mount between the drives.

### Installation of bracket

The bracket is designed for a standard 13° transom angle. For 2° to 10° or 19° to 22° transom angle, the shim is required.

1. Cut out the installation template (enclosed with transducer) along the dotted line.
2. At the selected location, position the template, so the arrow at the bottom is aligned with the bottom edge of the transom. Being sure the template is parallel to the waterline, tape it in place.

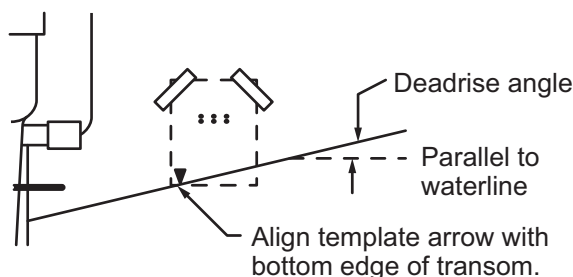
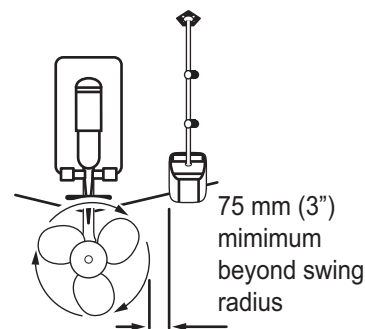

### *Positioning the template*

**Warning:** Always wear safety goggles and a dust mask.

3. Using a 4 mm, #23, or 9/64" bit, drill three holes 22 mm (7/8") deep at the locations indicated. To prevent drilling too deeply, wrap masking tape around the bit 22 mm (7/8") from the point.

**Fiberglass hull:** Minimize surface cracking by chamfering the gelcoat. If a chamfer bit or countersink bit is not available, start drilling with a 6mm or 1/4" bit to a depth of 1 mm (1/16").

4. Using the three #10 x 1-1/4" self-tapping screws, temporarily screw the bracket to the hull. **DO NOT** tighten the screws completely at this time. Follow the step 1-4 in "Attaching the sensor to the bracket", before proceeding with "Adjusting".
5. If you know your transom angle, the bracket is designed for a standard 13° transom angle.
  - 11°-18° angle: No shim is required. Skip to step 3 in "Adjustments".
  - Other angles: The shim is required. Skip to step 2 of "Adjustments".

## 1. MOUNTING

If you do not know the transom angle, temporarily attach the bracket and sensor to the transom to determine if the plastic shim is needed.

### Adjustments

- Using a straight edge, sight the underside of the sensor relative to the underside of the hull. The stern of the sensor should be 1-3 mm (1/16-1/8") below the bow of the sensor or parallel to the bottom of the hull.

**Note:** Do not position the bow of the sensor lower than the stern because aeration will occur.

- To adjust the sensor's angle relative to the hull, use the tapered plastic shim provided. If the bracket has been temporarily fastened to the transom, remove it. Key the shim in place on the back of the bracket.

**2°-10° transom angle (stepped transom and jet boats):** Position the shim with the tapered end down.

**19°-22° transom angle (small aluminum and fiberglass boats):** Position the shim with the tapered end up.

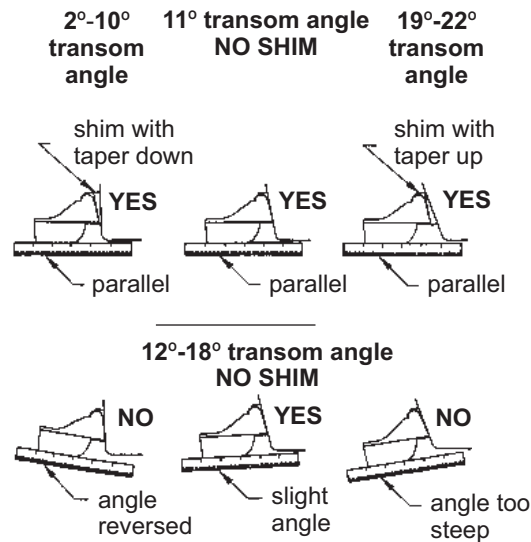

### *Sensor position and transom angle*

- If the bracket has been temporarily fastened to the transom, remove it. Apply marine sealant to the threads of the three #10 x 1-1/4" self tapping screws to prevent water seeping into the transom. Screw the bracket to the hull. Do not tighten the screws completely at this time.
- Repeat step 1 to ensure that the angle of the sensor is correct.

**Note:** Do not position the sensor farther into the water than necessary to avoid increasing drag, spray, and water noise and reducing boat speed.



- Using the vertical adjustment space on the bracket slots, slide the sensor up or down to provide a projection of 3 mm (1/8").
- Tighten the self tapping screws.

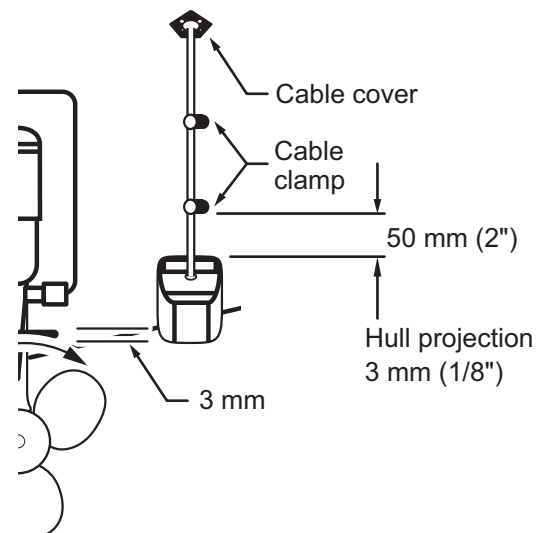

#### Attaching the sensor to the bracket

- If the retaining cover near the top of the bracket is closed, open it by depressing the latch and rotating the cover downward.
- Insert the sensor's pivot arms into the slots near the top of the bracket.
- Maintain pressure until the pivot arms click into place.
- Rotate the sensor downward until the bottom snaps into the bracket.
- Close the retaining cover to prevent the accidental release of the sensor when the boat is underway.

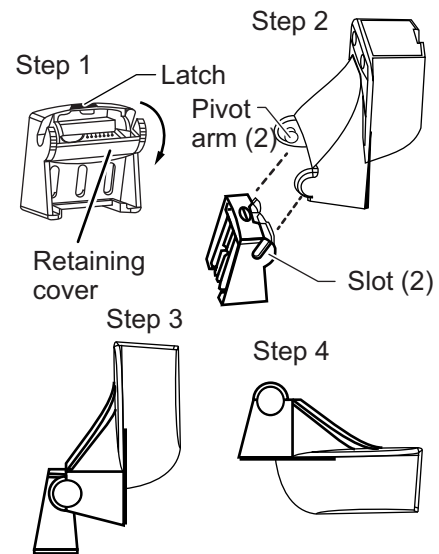

#### Cable routing

Route the sensor cable over the transom, through a drain hole, or through a new hole drilled in the transom above the waterline. If a hole must be drilled, choose a location well above the waterline. Check for obstructions such as trim tabs, pumps, or wiring inside the hull. Mark the location with a pencil. Drill a hole through the transom using a 19 mm or 3/4" bit (to accommodate the connector).

**Note:** Never cut the cable or remove the connector; this will void the warranty. Always wear safety goggles and a dust mask.

- Route the cable over or through the transom. On the outside of the hull secure the cable against the transom using the cable clamps. Position a cable clamp 50 mm (2") above the bracket and mark the mounting hole with a pencil.
- Position the second cable clamp halfway between the first clamp and the cable hole. Mark this mounting hole.
- If a hole has been drilled in the transom, open the appropriate slot in the transom cable cover. Position the cover over the cable where it enters the hull. Mark the two mounting holes.
- At each of the marked locations, use a 3 mm or 1/8" bit to drill a hole 10 mm (3/8") deep. To prevent drilling too deeply, wrap masking tape around the bit 10 mm (3/8") from the point.

## 1. MOUNTING

5. Apply marine sealant to the threads of the #6 x 1/2" self-tapping screw to prevent water from seeping into the transom. If you have drilled a hole through the transom, apply marine sealant to the space around the cable where it passes through the transom.
6. Position the two cable clamps and fasten them in place. If used, push the cable cover over the cable and screw it in place.
7. Route the cable to the instrument being careful not to tear the cable jacket when passing it through the bulkhead(s) and other parts of the boat. To reduce electrical interference, separate the sensor cable from other electrical wiring and "noise" sources. Coil any excess cable and secure it in place with zip-ties to prevent damage.

# 2. WIRING

## 2.1 Wiring

Refer to the below figures and interconnection diagram to connect cables. Also, be sure to cover and keep the waterproof caps of connectors that are not in use.

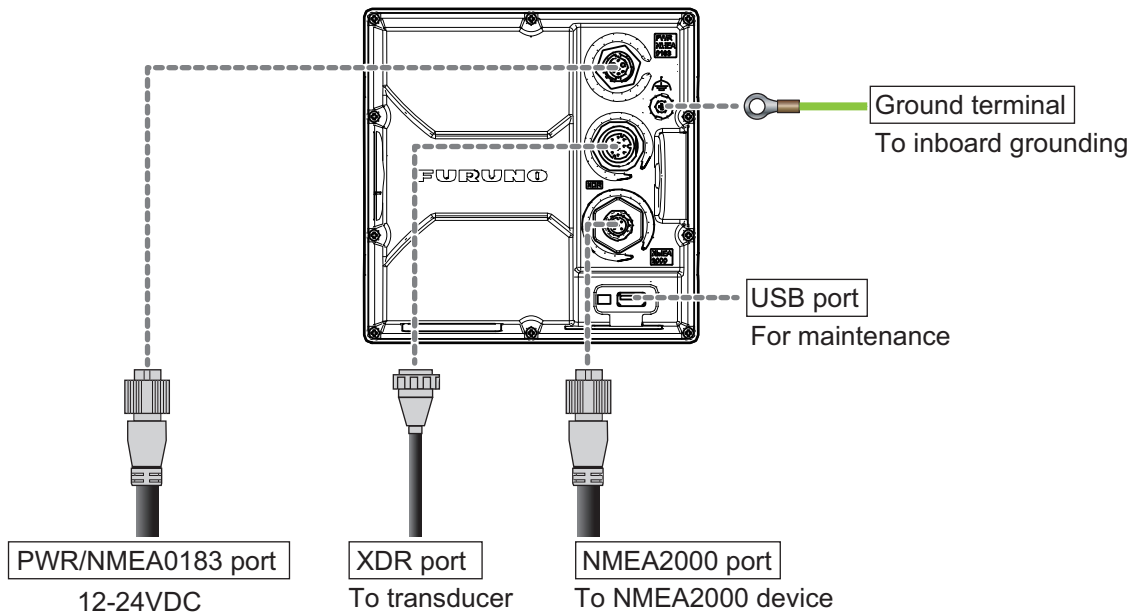

*Back side of FCV-600*

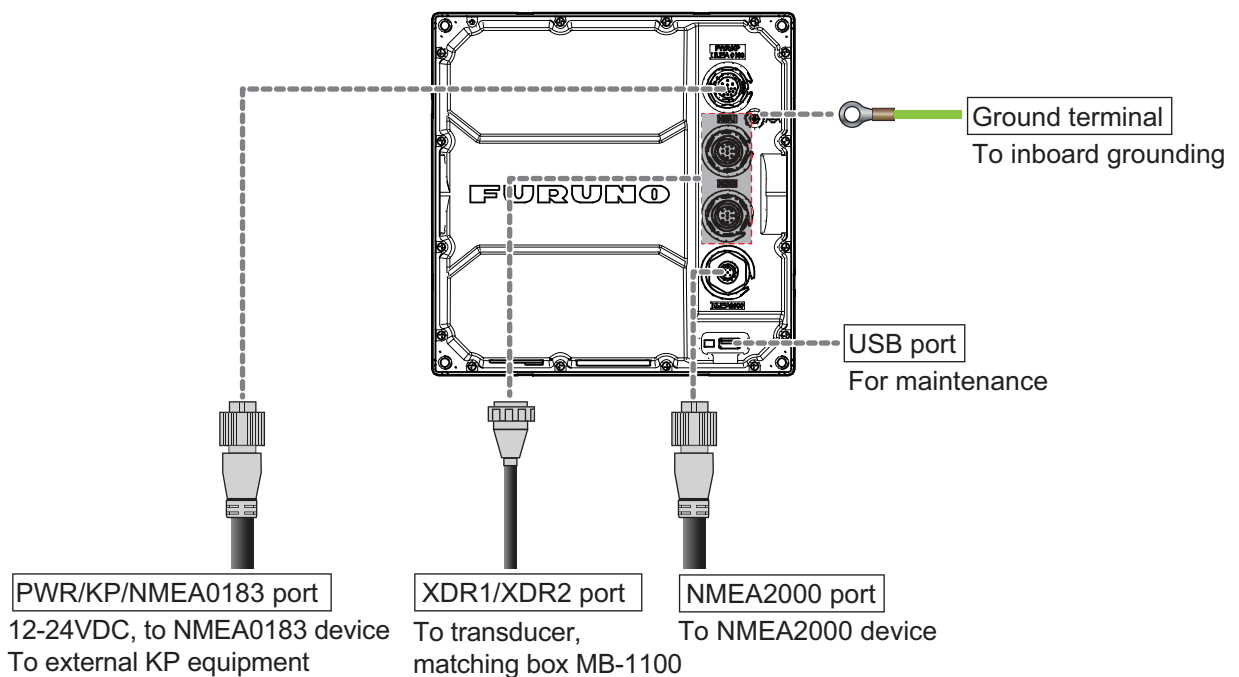

*Back side of FCV-800*

## 2. WIRING

### 2.1.1 Power/data cable and ground wiring

For FCV-600, connect the supplied FRU-CF-H07-02M cable (2m, single ended connector) to the [PWR/NMEA0183] port.

For FCV-800, connect the supplied FRU-CF-H16-02M cable (2m, single ended connector) to the [PWR/KP/NMEA0183] port.

The pinout of the power/data cable is as follows.

#### FRU-CF-H07-02M (FCV-600)

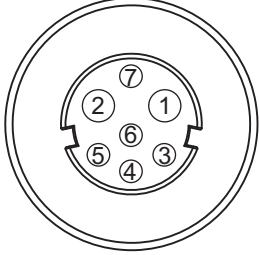
Pin No.	Signal name	Core color	Remarks	Pinout (front view)
1	DC-P	Red (bold)	Power input 12-24VDC	
2	DC-N	Blue (bold)		
3	TD-A	White	For Tankenmaru (not used)/ Raw echo data output	
4	TD-B	Blue		
5	NC	Yellow		
6	NC	Green		
7	SHIELD	Black	Drain wire (to GND terminal on switchboard)	

#### FRU-CF-H16-02M (FCV-800)

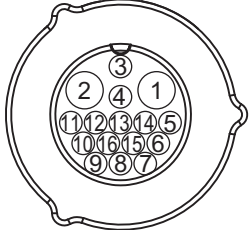
Pin No.	Signal name	Core color	Remarks	Pinout (front view)
1	DC-P	Red (bold)	Power input 12-24VDC	
2	DC-N	Blue (bold)		
3	TD1-A	White	NMEA0183 For navigation equipment connection/ Bottom Hardness	
4	TD1-B	Blue		
5	RD1-H	Yellow		
6	RD1-C	Green		
7	TD2-A	White/Black	For Tankenmaru (not used)/ Raw echo data out- put	
8	TD2-B	Blue/White		
9	EXT_KP_OUT-H	Yellow/Black	External KP Input/Output	
10	EXT_KP_OUT-C	Green/White		
11	EXT_KP_IN-H	Brown		
12	EXT_KP_IN-C	Orange		
13	NC	Pink		
14	NC	Gray		
15	NC	Red/White		
16	SHIELD	Black	Drain wire (to GND terminal on switchboard)	

**Note 1:** Cut unused cores and tape them.

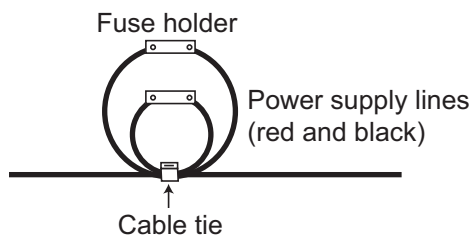

**Note 2:** Connector of cable edge breaks easily. Be careful when connecting or disconnecting the connector.

**Note 3:** The fuse holder contains a spring which fixes the fuse. To prevent detachment of the spring, which would cause loss of power, tie the lines as shown below.



### **How to ground the main unit**

- Use a 1.25 sq wire (local supply) for the ground wire.
- Make the length of the ground wire as short as possible and connect it to the boat's ground.
- For FRP vessels, attach a steel plate measuring 20 cm by 30 cm on the outside of the hull to provide a ground point. Connect the ground wire there.

**Note 1:** Use a ring-type lug (  ) to make the connection at the main unit. Do not use a fork-type lug (  ).

**Note 2:** External equipment should not be connected to the fish finder if the signal ground of the external equipment and the positive DC terminal of the fish finder are connected to the boat's ground.

### **Connection of the power cable inboard**

Connect the power wire of the power/data cable to the vessel power supply (12-24 VDC).

### **Connection of NMEA0183 and external KP devices (FCV-800 only)**

Connect the signal wires of power/data cables used for NMEA0183 (navigation device, wind sensor) and external KP.

## **2.1.2 Transducer cable connection**

For FCV-600, connect the transducer cable to the [XDR] port.

For FCV-800, the type and combination of transducer determines the port to which the transducer cable is connected.

**Note:** Supply voltages are different depending on XDR ports. Be sure to connect each transducer to the correct port (see the table below).

<b>Transducer</b>	<b>Connection port</b>
CW transducer connection only. Compatible transducers: 520-5PSD, 520-5MSD, 520-PLD, 525-5PWD, 525STID-PWD, 525STID-MSD, 525T-PWD, 525T-BSD, 525T-LTD/12, 525T-LTD/20, SS60-SLTD/12, SS60-SLTD/20, 200B-5S, 50B-6, 50B-6B, 50/200-1T, 526TID-HDD	[XDR1]
Single frequency (LF) CHIRP transducer connection (LF: Low Frequency). Compatible transducers: B-75L, B-175L, etc.	[XDR1]
Single frequency (MF/HF) CHIRP transducer connection (MF: Medium Frequency, HF: High Frequency). Compatible transducers: TM150M, B-75H, B-175H, etc.	[XDR2]

## 2. WIRING

Transducer	Connection port
Dual frequency CHIRP transducer connection*. Compatible transducers: B265LH-FJ12, TM265LH-FJ12, CM265LH-FJ12, etc.	[XDR1], [XDR2]
Simultaneous connection of single frequency (LF) CHIRP and single frequency (MF/HF) CHIRP transducers. Compatible transducers: Only in the below combinations <ul style="list-style-type: none"> <li>• LF: B-75L, MF: B150M/B75M, HF: B-75H</li> <li>• LF: SS75L, MF: SS75M, HF: SS75H</li> <li>• LF: B-175L, MF: B175M, HF: B-175H/B175HW</li> </ul>	[XDR1]: CHIRP (LF) [XDR2]: CHIRP (MF/HF)
Simultaneous connection of CW and single frequency (MF/HF) CHIRP transducers. Compatible transducers: See above. <b>Note:</b> Simultaneous connection of CW and single frequency (LF) CHIRP transducers is not available.	[XDR1]: CW [XDR2]: CHIRP

\*:When connecting dual frequency CHIRP transducer, an optional cable assembly (type: FRU-MJ10CCB12-300) is required.

**Note:** When using the optional extension cable (for 10-pin: C332 10M, for 12-pin: FRU-CCB12-DA-10M), keep the following points in mind.

- Detection performance may be degraded.
- False positives (under-display of fish length, reduced number of detections, false detection of single fish) may occur when using the ACCU-FISH™ function.
- Values measured by the ship speed sensor may differ from the actual values.
- TD-ID may not work.

### Matching box for 1kW transducer

The optional matching box (type: MB-1100) is required to connect the 1kW transducers (however, for 526TID-HDD matching box is not required).

Part	Type	Code no.	Qty
Matching Box*	MB-1100	000-027-226	1
Crimp-on Lug	FV1.25-3 (LF)	000-116-756-10	6
Cord Lock**	NC-1	000-168-230-10	1

\*: With 10P connector cable

\*\* : For connecting two transducers

Connect the transducer cables to the matching box as shown below.

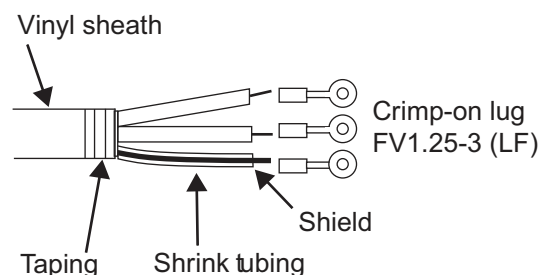



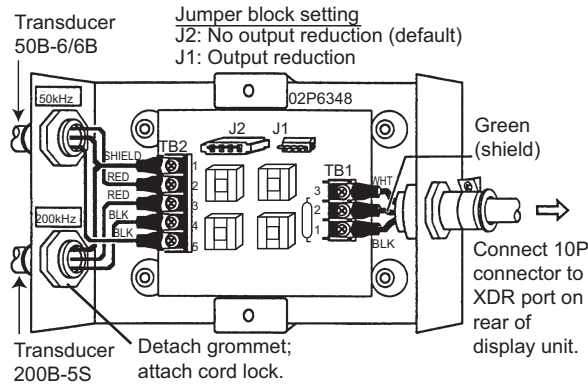

### 2.1.3 NMEA2000 device connection

Use the optional FRU-NMEA-PMMFF cable (1m, 2m, 6m, both end connectors) or FRU-NMEA-PFF (1m, 2m, 6m, single end connector) to connect to the backbone of NMEA2000 (CAN bus) network. The NMEA2000 device must be connected to the same backbone as the NMEA2000 devices (GPS receiver and Satellite Compass™) used as data sources for the monitoring system.

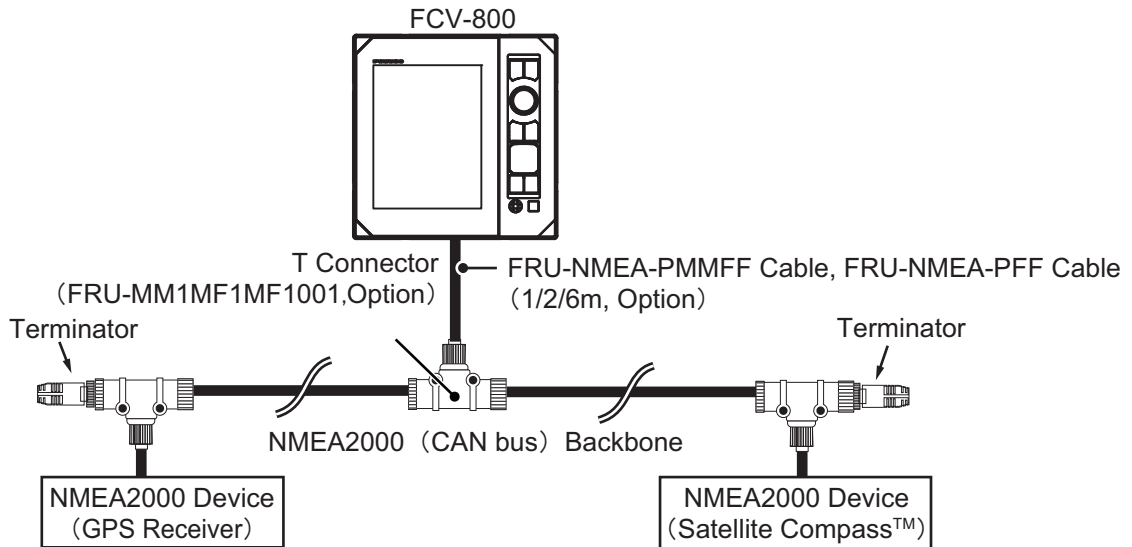

**Note 1:** NMEA2000 corresponds to CAN bus, so CAN bus devices can also be connected.

**Note 2:** The NMEA2000 (CAN bus) network requires a dedicated NMEA2000 power supply. Turn on the power for the NMEA2000 network before turning on the system.

**Note 3:** Terminators must be installed at both ends of the backbone cable of the NMEA2000 (CAN bus) network. The following table shows the optional terminators available for the NMEA2000.

Name	Type	Code No.	Remarks
Connector (NMEA)	FRU-MM1000000001	001-507-070	Male
	FRU-MF000000001	001-507-060	Female

## 2.2 Data Sentences/PGN Data Sentences

### 2.2.1 NMEA0183 (FCV-800 only)

The table below shows the data sentences which can be input to and output from your fish finder.

Input data sentences

Sentence	Meaning	Version
BWC	Bearing (magnetic) and distance to waypoint	Ver. 1.5/2.0/3.0/4.0/4.1
GGA	Global positioning system (GPS) fix data	Ver. 1.5/2.0/3.0/4.0/4.1
GLL	Geographic position - latitude/longitude	Ver. 1.5/2.0/3.0/4.0/4.1
GNS	GNSS fix data	Ver. 3.0/4.0/4.1
HDG	Heading, deviation and variation	Ver. 2.0/3.0/4.0/4.1
HDT	Heading, true	Ver. 1.5/2.0/3.0/4.0/4.1
MDA	Atmospheric pressure	Ver. 1.5/2.0/3.0/4.0/4.1
MTW	Water temperature.	Ver. 1.5/2.0/3.0/4.0/4.1
MWV	Wind speed and angle	Ver. 2.0/3.0/4.0/4.1
RMA	Lat/Lon, SOG, course	Ver. 1.5/2.0/3.0/4.0/4.1
RMB	Nav data (waypoint, etc.)	Ver. 1.5/2.0/3.0/4.0/4.1
RMC	Lat/Lon (GPS), SOG, course	Ver. 1.5/2.0/3.0/4.0/4.1
THS	Heading, true	Ver. 4.0/4.1
VHW	Water speed and heading	Ver. 1.5/2.0/3.0/4.0/4.1
VTG	Course over ground and ground speed	Ver. 1.5/2.0/3.0/4.0/4.1
XTE	Cross track error	Ver. 1.5/2.0/3.0/4.0/4.1
ZDA	Time and date	Ver. 1.5/2.0/3.0/4.0/4.1
GPatt	FURUNO original sentence	-
GPhve	FURUNO original sentence	-
pireq	FURUNO original sentence	-

Order of priority

<u>Data</u>	<u>Priority</u>
Latitude/Longitude:	GNS>GGA>RMC>RMA>GLL
Course (true):	VTG>RMC>RMA
Course (magnetic):	VTG
Ground speed:	VTG>RMC>RMA
Water speed:	VHW
Distance to waypoint:	BWC>RMB
Bearing to waypoint (true):	BWC>RMB
Bearing to waypoint (magnetic):	BWC
Heading (true):	THS>HDT>VHW
Heading (magnetic):	HDG>VHW
Cross track error:	XTE>RMB
Water temperature:	MTW

Wind speed and angle (true):	MWV
Wind speed and angle (apparent):	MWV
Atmospheric pressure:	MDA
Time:	ZDA
Heave:	GPhve
Roll&Pitch:	GPatt
Magnetic Variation:	HDG > RMC > RMA

Output data sentences

Sentence	Meaning	Version
DBS	Depth from sea surface	Ver. 1.5/2.0/3.0/4.0/4.1
DBT	Depth below transducer	Ver. 1.5/2.0/3.0/4.0/4.1
DPT	Depth	Ver. 2.0/3.0/4.0/4.1
MTW	Water temperature	Ver. 1.5/2.0/3.0/4.0/4.1
RMB	Recommended minimum navigation information	Ver. 1.5/2.0/3.0/4.0/4.1
TLL	Target position	Ver. 3.0/4.0/4.1
VHW	Speed through the water	Ver. 1.5/2.0/3.0/4.0/4.1
pidat	FURUNO original sentence	-
SDbhr	FURUNO original sentence	-
SDmrk	FURUNO original sentence	-
SDtbd	FURUNO original sentence	-
SDtfl	FURUNO original sentence	-

## 2.2.2 NMEA2000

The following PGNs can be input and output.

input PGN

PGN	PGN name
059392	ISO Acknowledgement
059904	ISO Request
060160	ISO Transport Protocol, Data Transfer
060416	ISO Transport Protocol, Connection Management - BAM group function
060928	ISO Address Claim
061184	FURUNO original PGN
065240	ISO Commanded Address
065280	FURUNO original PGN
126208	NMEA - Request group function
	NMEA - Command group function
	NMEA - Acknowledge group function
126720	FURUNO original PGN
126996	Product Information
127250	Vessel Heading
127252	Heave
127257	Attitude
128259	Speed, Water referenced

2. WIRING

PGN	PGN name
129025	Position, Rapid Update
129026	COG & SOG, Rapid Update
129029	GNSS Position Data
129283	Cross Track Error
129284	Navigation Data
130306	Wind Data
130310	Environmental Parameters - DEPRECATED
130311	Environmental Parameters - DEPRECATED
130312	Temperature - DEPRECATED
130314	Actual Pressure
130316	Temperature, Extended Range
130577	Direction Data
130821	FURUNO original PGN

output PGN

PGN	PGN name	Transmission Interval (msec)
059392	ISO Acknowledgement	-
059904	ISO Request	-
060928	ISO Address Claim	-
061184	FURUNO original PGN	-
126208	NMEA - Command group function	-
	NMEA - Acknowledge group function	-
126464	PGN List - Transmit PGN's group function	-
	PGN List - Received PGN's group function	-
126720	FURUNO original PGN	-
126993	Heartbeat	60,000
126996	Product Information	-
126998	Configuration Information	-
128259	Speed, Water referenced	1,000
128267	Water Depth	1,000
130310	Environmental Parameters - DEPRECATED	500
130312	Temperature - DEPRECATED	2,000
130316	Temperature, Extended Range	2,000
130821	FURUNO original PGN	-
130822	FURUNO original PGN	-
130830	Target Information (PPGN)	-
130831	Target Bottom Classification Data (PPGN)	-
130832	Target Fish Length (PPGN)	-

# 3. INITIAL SETTINGS

## 3.1 Language and Transducer Settings

1. Press the /BRILL key to show the [Installation] menu.

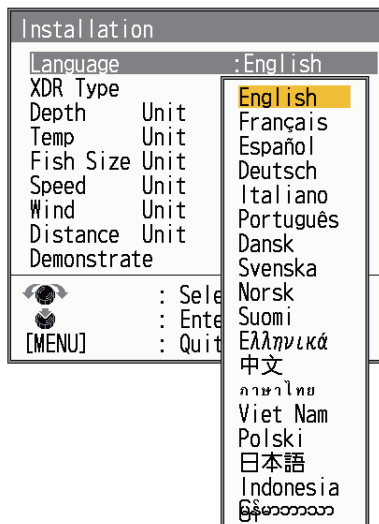

For FCV-600

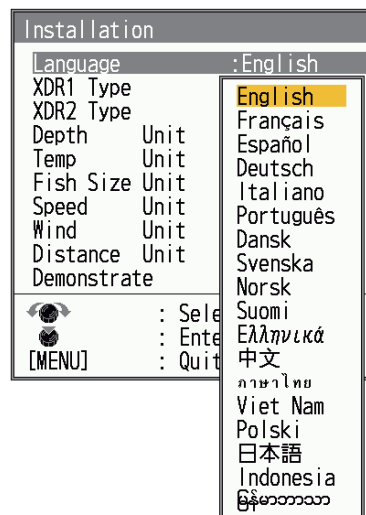

For FCV-800

2. Select your language, then press the **KNOB**. The units for depth, water temperature, fish length, ship speed, wind speed and distance are set according to the language selected. Continue the procedure to select the transducer.
3. Select [XDR Type] (for FCV-600) or [XDR1 Type] (for FCV-800) and press the **KNOB**.

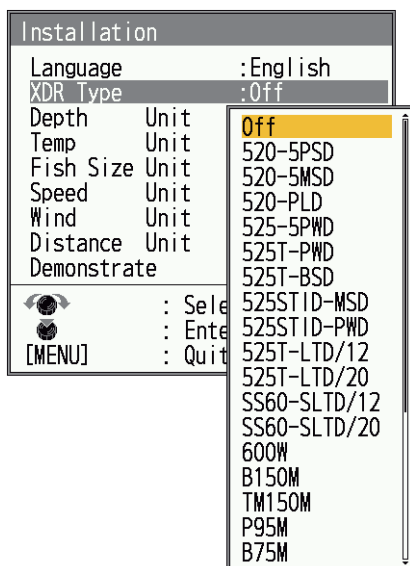

For FCV-600

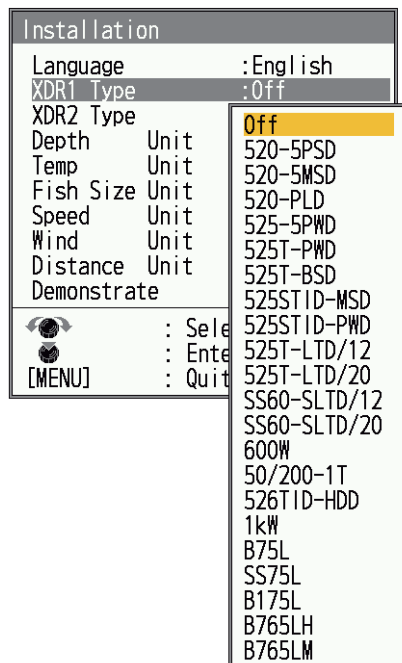

For FCV-800

4. Select the model of transducer connected to the [XDR] (for FCV-600) or [XDR1] (for FCV-800) port and press the **KNOB**. If you use a model of CW transducer that

### 3. INITIAL SETTINGS

is not shown on the list in step 3, depending on the transmission output, select [600W] or [1kW] (for FCV-800 only).

**Note 1:** Make sure to select the appropriate transducer. Otherwise the connected transducer will be damaged.

**Note 2:** You can view and modify transducer settings on the [Transducer] menu from the [System] menu (see Operator's Manual for further information).

5. If the transducer is connected to [XDR2] port, select [XDR2 Type] on the menu and select the appropriate transducer (for FCV-800 only).
6. Press the **MENU/ESC** key to close the menu. "Restart to apply changes?" message appears.
7. Select [Yes] and press the **KNOB** to finish.

## 3.2 Input/Output Settings

This section describes how to adjust input/output data settings.

### 3.2.1 Data source settings

On the [Data Source] setting window, select the desired sensor for SOG, STW, Nav Data, Heading, Position, Wind Spd/Dir, Atmos Press. (Atmospheric Pressure), Water Temperature and heave.

1. Turn on the power of all the connected sensors.
2. Press the **MENU/ESC** key to show the main menu.
3. Select [Network] from the [System] menu, then press the **KNOB**.

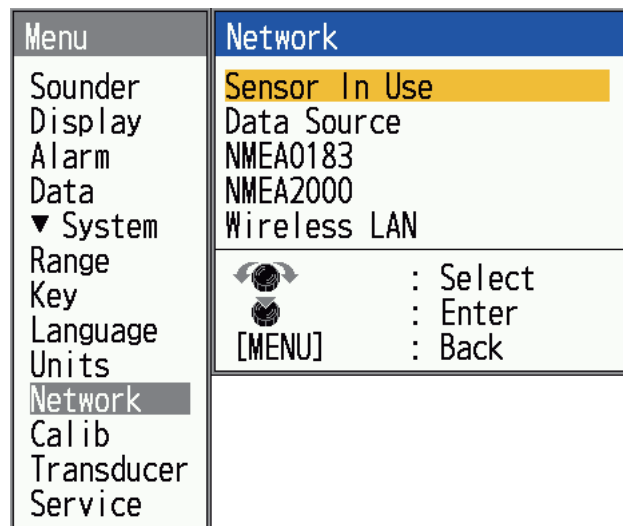

Example of FCV-800 display

- Select [Data Source] and press the **KNOB**. [Data Source] setting window will be shown.

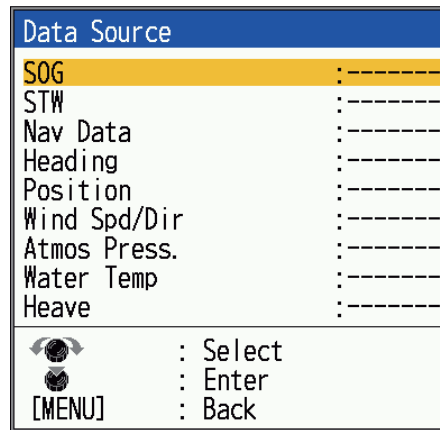

- Select the desired data and press the **KNOB**. Selection window for data source will be shown. The example display on the right is shown when [SOG] is selected.
- Select one of the following data sources and press the **KNOB**. The choices displayed in the [Data Source] selection window depend on the item selected in step 5.

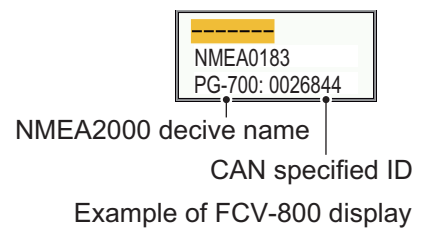

- [-----]: Unselected
  - **[NMEA0183]** (for FCV-800 only): Data is imported from NMEA0183 device connected to the [PWR/KP/NMEA0183] port.
  - **[XDR], [XDR1]** (for FCV-800 only): Data is imported from transducer connected to the [XDR] (for FCV-600) or [XDR1] (for FCV-800) port.
  - **[XDR2]** (for FCV-800 only): Data is imported from transducer connected to [XDR2] port.
  - **NMEA2000/CAN ID:** Data is imported from NMEA2000 device connected to [NMEA2000] port. If multiple devices are connected to the same network, the names of all devices are displayed. Select the desired device for data source.
- Repeat step 5 to step 6 and set all data sources.
  - Press the **MENU/ESC** key twice to close the menu.

### 3. INITIAL SETTINGS

#### **[Sensor In Use] list**

You can check the data sources of the currently used sensors in the [Sensor In Use] of the [Network] menu. If no data is entered, [-----] will be displayed.

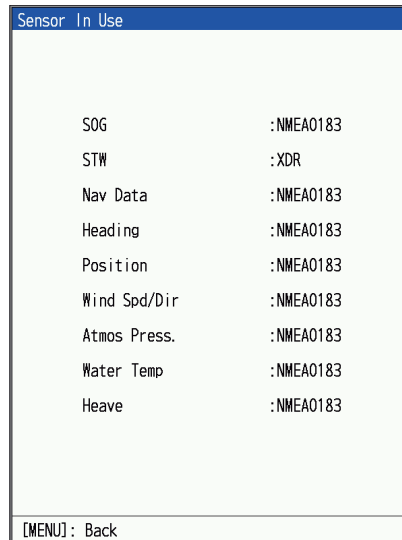

Example of FCV-800 display

#### **3.2.2 NMEA0183 port settings (FCV-800 only)**

Adjust the nav equipment settings connected to the [PWR/KP/NMEA0183] port.

1. Press the **MENU/ESC** key to show the main menu.
2. Select [Network] and press the **KNOB**.
3. Select [NMEA0183] and press the **KNOB**.

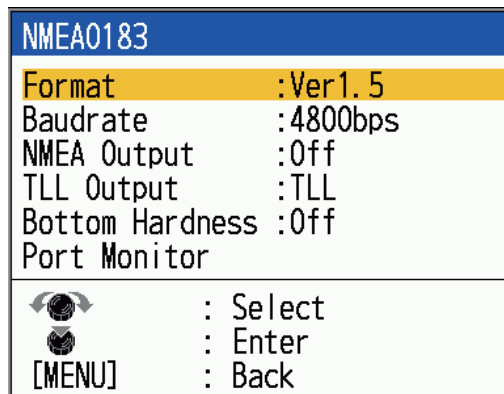

4. See the below table to adjust the NMEA0183 settings.

Name	Explanation
[Format]	Select the version of nav equipment connected to [PWR/KP/NMEA0183] port. Available versions are [Ver 1.5], [Ver 2.0] or [Ver 3.0/4.0/4.1].
[Baudrate]	Select [4800bps] or [38400bps] for the baudrate.
[NMEA Output]	Select what data sentences to output. <ul style="list-style-type: none"> <li>• [Off]: Do not output the NMEA0183 data sentences.</li> <li>• [On]: Output the NMEA0183 data sentences. However, do not output data that is input from other equipment.</li> </ul>



Name	Explanation
[TLL Output]	Output the position specified by the <b>MARK</b> key to the connected plotter. <ul style="list-style-type: none"> <li>• [Off]: Do not output latitude/longitude.</li> <li>• [TLL]: Output latitude/longitude.</li> <li>• [FURUNO-TLL]: Output latitude/longitude, depth and water temperature. Requires [FURUNO-TLL] enabled device.</li> </ul>
[Bottom Hardness]	Shown only when the transducer that supports hardness* is connected. Select [On] to output the hardness sentence (SDBhr).

\*: See the equipment list on page 2.

5. Press the **MENU/ESC** key twice to close the menu.

### **[Port Monitor] menu**

Port Monitor window shows the data sentence information input to the [PWR/KP/NMEA0183] port. Press the **KNOB** to display the latest data sentence information.

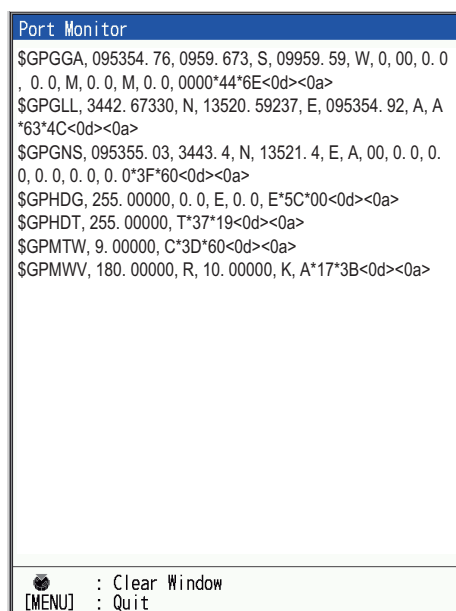

### **3.2.3 Information/reception status of NMEA2000**

The [NMEA2000] window allows you to view information/reception status of NMEA2000 devices that are on the same NMEA2000 network as the unit. You can also change settings related to output of NMEA2000.

1. Press the **MENU/ESC** key to show the main menu.
2. Select [Network] and press the **KNOB**.
3. Select [NMEA2000] and press the **KNOB**.

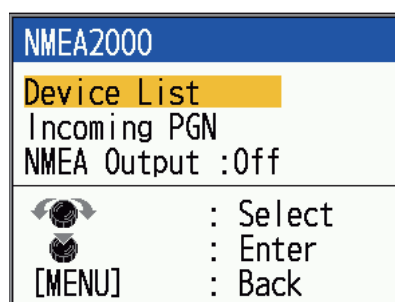

### 3. INITIAL SETTINGS

- Select [Device List] to show the list of other connected equipments and press the **KNOB**. Select the device from the list and press the **KNOB** to show the [Device Info] display.

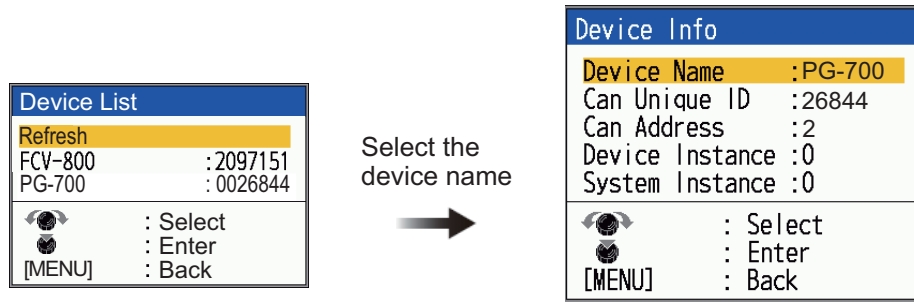

Example of FCV-800 display

Adjust the value of [Device Instance] and [System Instance].

**Note:** To see the latest information, select [Refresh] on the [Device List] window.

- Select [Incoming PGN] and press the **KNOB** to show status of NMEA2000 incoming PGN list. Received data is displayed in black, while data not yet received is displayed in gray (updated in one-second cycles). The middle section of the window shows the information of the PGN selected by the selection cursor (shown in yellow).

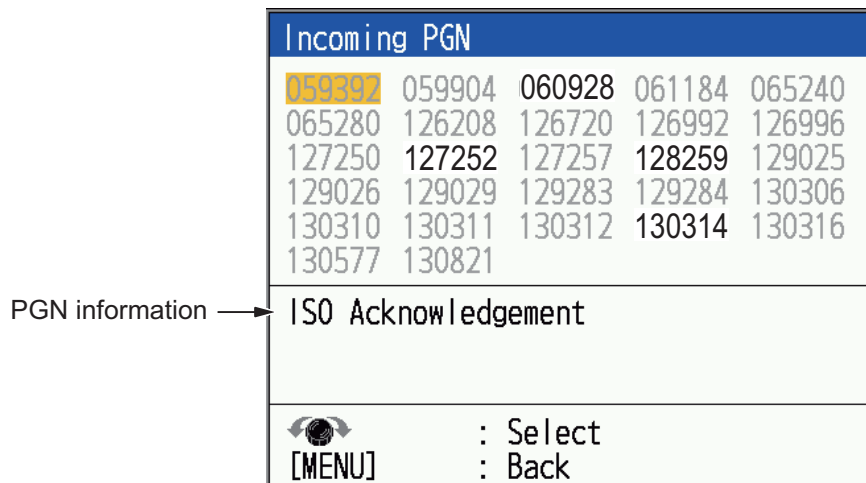

- Select [NMEA Output] and press the **KNOB** to adjust what data sentences to output.
  - [Off]:** Do not output the 128259, 128267, 130310, 130312, 130316, 130830, 130831, 130832 PGN data sentences.
  - [On]:** Output the 128259, 128267, 130310, 130312, 130316, 130830, 130831, 130832 PGN data sentences.
- Press the **MENU/ESC** key twice to close the menu.

## 3.3 Wireless LAN setup

When connected to wireless LAN, the following operations become available:

- View FCV-600 or FCV-800 fish finder images and voyage information on your iOS or Android™ device (for iOS: only one device can be connected).
- Use the FCV main unit\* as a sub monitor (only one sub-monitor can be connected).  
\*: FCV-600 or FCV-800 wireless LAN connection is required.

The sub monitor displays the fish finder images of the main monitor. The sub monitor can also be used to change settings for the main monitor (only for certain functions).

### Notice regarding use of wireless LAN

- The wireless LAN function is available only in the countries which have acquired radio wave certification. Turn wireless LAN off in countries which do not have the certification. Ocean-going vessels that have radio wave certification are able to use the wireless LAN in any country that has acquired radio wave certification. Vessels with radio wave certification that enter a country that does not have the certification, may use the wireless LAN only inboard. Available countries (as of January, 2022): USA, Canada, New Zealand, Australia, Japan, UK and all countries of the EU.
- The communication rate and effective range for the wireless LAN can be affected by electromagnetic waves, interfering objects, or access point location.
- We strongly recommend using a wireless LAN with encrypted connection. Otherwise unauthorized access by a third party can occur, which can cause loss of data or system crash.
- We recommend changing the initial password when using a local wireless network.
- If wireless LAN communication fails while using the microwave oven, turn off the microwave oven.

### 3.3.1 LAN settings on the FCV main unit (main monitor side)

Do the following procedure when using the FCV as a standard unit or as the main monitor.

1. Press the **MENU/ESC** key to show the main menu.
2. Select [Network] and press the **KNOB**.
3. Select [Wireless LAN] and press the **KNOB**.

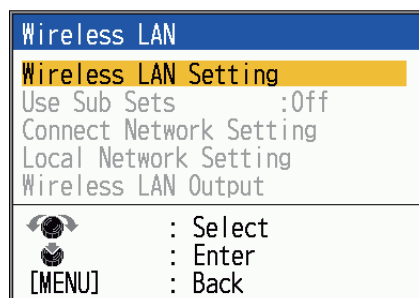

Enabled when the [Wireless LAN] is set to [On] in the [Wireless LAN Setting] window

### 3. INITIAL SETTINGS

4. Select [Wireless LAN Setting] and press the **KNOB**.

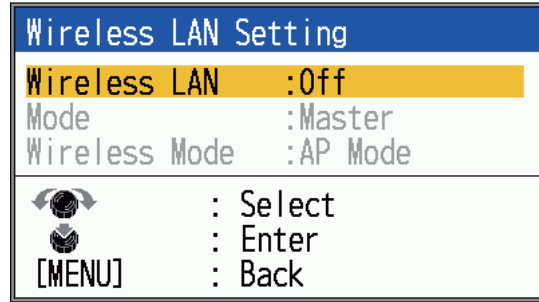

5. Select [Wireless LAN] and press the **KNOB**.
6. Select [On] and press the **KNOB**.
7. Select [Mode] and press the **KNOB**.
8. Select [Master] and press the **KNOB**.
9. Select [Wireless Mode] and press the **KNOB**.
10. Select one of the following settings and press the **KNOB**.
  - [AP Mode]: Use the FCV main unit (main monitor) as an access point.
  - [Client Mode]: Use existing access point.
11. Press the **MENU/ESC** key.

The confirmation message "Restart to apply changes?" appears.
12. Select [Yes] and press the **KNOB**.

The system restarts. After restarting, if you selected "AP Mode" in step 10, a wireless LAN icon (  ) will appear in the upper right corner of the screen. This icon indicates that the FCV is used as an access point.
13. Repeat step 1 to 3 to show the [Wireless LAN] setting window.
14. Depending on the item selected in step 10, do one of the following procedures.

#### **For [AP Mode]**

- 1) Select [Local Network Setting] on the [Wireless LAN] menu.

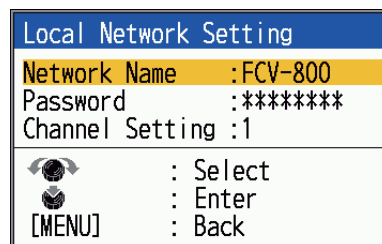

Example of FCV-800 display

- 2) To change the network name (factory default: the model name of the unit), select [Network Name] and press the **KNOB**.

[Network Name] display will be shown. If no changes are required, go to step 4.

3) Change to the desired name (maximum 32 characters).

a) Select the typing mode (abc, ABC, ?123, ~[<) and press the **KNOB**.

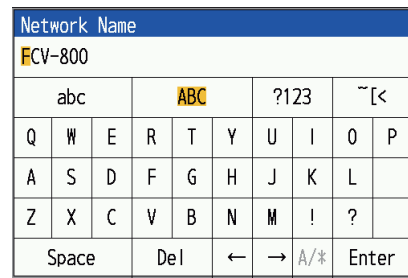
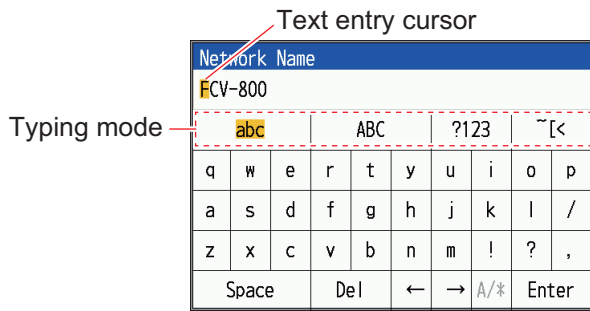

Typing mode: Alphabet (lowercase letters)

Typing mode: Alphabet (uppercase letters)

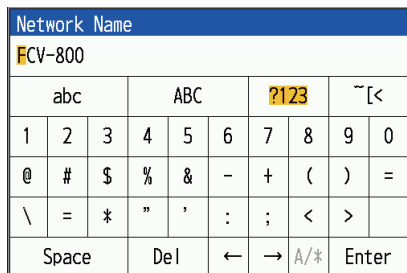

Typing mode: Numerical

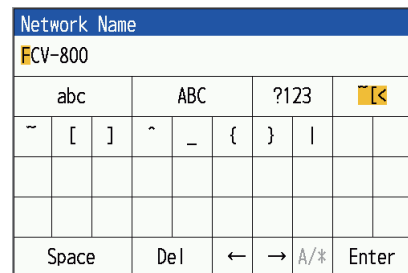

Typing mode: Symbol

b) Select a character and press the **KNOB**.

c) Repeat a) and b) and type the name. To delete any character, select [←] or [→] and press the **KNOB** to move the cursor to the character you want to delete. Then select [Del] and press the **KNOB**.

d) Select [Enter] and press the **KNOB**.

4) Select [Password] and press the **KNOB**.

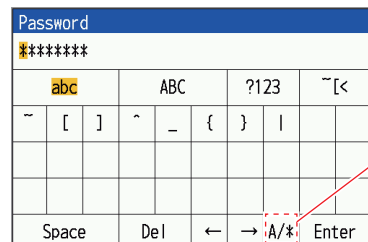

Switch between plain text and symbols display

5) Refer to step 3) above and change the password (maximum 40 characters).

Depending on the [A/\*] setting, the password will appear as follows.

Plaintext: Displays all typed characters.

Ciphertext: Typed characters are displayed as ""\*".

6) In case of difficulty to connect due to multiple LAN environments, change the channel settings.

a) Select [Channel Setting] and press the **KNOB**.

b) Select a channel (from 1 to 11) and press the **KNOB**.

7) Press the **MENU/ESC** key.

“Restart to apply changes?” message appears.

8) Select [Yes] and press the **KNOB**.

### 3. INITIAL SETTINGS

#### **For [Client Mode]**

- 1) Select [Connect Network Setting] and press the **KNOB**.

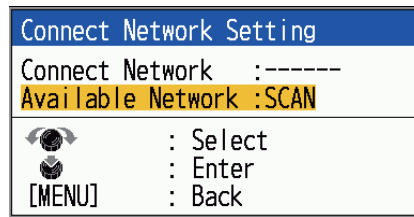

- 2) With [Available Network] selected, press the **KNOB**. When an available network near the unit is detected, the name of the network is displayed in the [Network List] window.

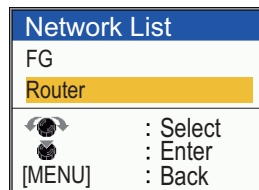

- 3) Select the network to connect and press the **KNOB**. The following window will be displayed.

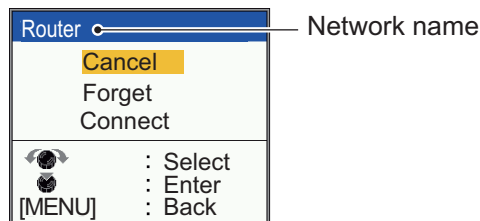





- 4) Select [Connect] and press the **KNOB**. [Password] setting window will be shown.

**Note:** If you want to erase the password for the last connected network, select [Forget] before [Connect]. The password will be erased all at once, making it easier to enter the new password when connecting to a different network.

- 5) Enter the password for the network.

See page 35 "For [AP Mode] (local network setting)" to select the typing mode. After entering the password and when the connection to the network is complete, the "Connecting..." message will disappear and the wireless LAN icon () will appear in the upper right corner of the screen. The LAN icon indicates that access point other than the FCV is being used. If the message "Connection failed" is displayed, the password you entered may be incorrect. Press the **MENU/ESC** key and repeat step 3) to 5).

**Note:** Bar on the wireless LAN icon indicates the signal strength.

Symbol	Meaning	Symbol	Meaning
3 (  )	Strong	1 (  )	Weak
2 (  )	Average	0 (  )	Extremely weak/ No connection

**For sub monitor**

1. Press the **MENU/ESC** key to show the main menu.
2. Select [Network] and press the **KNOB**.
3. Select [Wireless LAN] and press the **KNOB**.

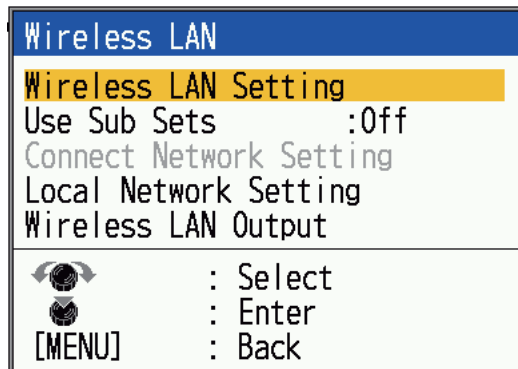

4. Select [Use Sub Sets] and press the **KNOB**.
5. Select one of the following and press the **KNOB**.
  - [On]: Reflects setting changes made on the sub monitor side to the main monitor.
  - [Off]: Do not reflect setting changes made on the sub monitor side on the main monitor.
6. Press the **MENU/ESC** key twice to close the menu.

**Wireless LAN output data settings**

Do the following procedure to output depth, navigation or weather data.

1. Press the **MENU/ESC** key to show the main menu.
2. Select [Network] and press the **KNOB**.
3. Select [Wireless LAN] and press the **KNOB**.
4. Select [Wireless LAN Output] and press the **KNOB**.

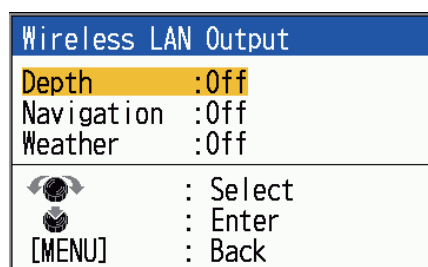

5. Select [Depth], [Navigation] or [weather] and press the **KNOB**.
6. Select [On] and press the **KNOB**.
7. Press the **MENU/ESC** key twice to close the menu.

### 3. INITIAL SETTINGS

#### 3.3.2 LAN settings on the sub monitor side

Do the following procedure when using the FCV as a sub monitor.

1. Press the **MENU/ESC** key to show the main menu.
2. Select [Network] and press the **KNOB**.
3. Select [Wireless LAN] and press the **KNOB**.
4. Select [Wireless LAN Setting] and press the **KNOB**.
5. Select [Wireless LAN] and press the **KNOB**.
6. Select [On] and press the **KNOB**.
7. Select [Mode] and press the **KNOB**.
8. Select [Sub] and press the **KNOB**.
9. Check that the [Wireless Mode] is set as [Client Mode].

**Note:** The main monitor and sub monitor should use the same network.

10. Continue from the page 35 step 11 to finish.

**Note:** Check the wireless LAN icon (bar) in the upper right corner of the sub monitor display. A Location with two or more bars are recommended for installation.

#### 3.3.3 LAN settings on the iOS or Android™ device



If you are using an iOS device or Android™, carry out the following settings.

- Network name set for the FCV main unit
- Password of the network set for the FCV main unit.

**Note:** The FCV and the iOS /Android™ should be connected on the same network.

### 3.4 Calibration settings

1. Press the **MENU/ESC** key to show the main menu.
2. Select [Calib] and press the **KNOB**.

Menu	Calibration
Sounder	Draft :+0.0ft
Display	Gain Adj CW HF :+0
Alarm	Gain Adj CW LF :+0
Data	Temp :+0.0°F
▼ System	Speed(STW) :+0%
Range	Fish Size :+0%
Key	Water Type :Salt
Language	Zero Line
Units	Rejector :0n
Network	Area :4.5ft
Calib	Bottom Detect :0.0ft
Transducer	Bottom Level XDR1:+0
Service	Bottom Level XDR2:+0
	Bottom Hardness :+0
	Heave Sensor Setting
	 : Select
	 : Enter
	[MENU] : Back

Example of FCV-800 display



3. See the table below to adjust the calibration settings.

Name	Explanation
[Draft]	To display the depth from the sea surface, set the ship's draft value.
[Gain Adj CHIRP HF/ MF / LF]* <sup>1</sup>	To set the gain higher or lower, or to adjust the balance of gain between low frequency and high frequency.
[Gain Adj CW HF/ LF]* <sup>1</sup>	
[Temp]	Compensates the errors in water temperature data. For example, if the displayed value is 35.6°F (2°C) higher than the actual water temperature, set "28.4°F" (-2°C) to correct.
[Speed (STW)]	Compensates the errors in vessel speed data. For example, if the displayed value is 10% lower than the actual vessel speed, set "+10%" to compensate.
[Fish Size]	Compensates the displayed value of the fish size.
[Water Type]	Select whether to use in seawater or freshwater as the water type. Salinity and other factors affect the speed of sound, causing errors in depth display.
[Zero Line], [Rejector]	When set to [On], the oscillation line rejection function is activated and fish school reactions near the surface can be identified. The length of the oscillation line tailing off varies depending on the type of transducer and the installation conditions. If you are using a transducer with an oscillation line longer than 4.5 ft, change the setting in the [Area] menu below.
[Zero Line], [Area]	This setting is enabled when the [Rejector] is set to [On]. If the tail of the oscillation line is long, set a higher value. If the oscillation line does not disappear, decrease the value of the transmit output.
[Bottom Detect]	Depending on the installation of the transducer, tailing of the oscillation line or reverberation echoes may be shown as seabed. In such cases, set a higher value. Shallower depths than the set value will no longer be detected.
[Bottom Level XDR] * <sup>2</sup>	The factory default setting is "0" and continuous strong echo level is recognized as seabed. If the depth display is unstable, adjust the bottom detection level. If a line appears in the seafloor line magnification screen, lower the bottom level to make the line disappear. <b>Note:</b> If the bottom level is set too low, a dense school of fish may be detected as seabed.
[Bottom Level XDR1] * <sup>3</sup> /	
[Bottom Level XDR2]* <sup>3</sup>	
[Bottom Hardness]* <sup>3</sup>	Compensates the NMEA0183 output hardness value.
[Heave Sensor Setting]	See section 3.5.

\*1: The items displayed will vary depending on the connected transducer.

\*2: Displayed for FCV-600 only.

\*3: Displayed for FCV-800 only.

4. Press the **MENU/ESC** key twice to close the menu.

### 3.5 Heave Sensor Settings

[Heaving Sensor Setting] window allows you to adjust settings related to heaving compensation.

**Note 1:** Satellite Compass™ connection is required to use the heaving correction function. If no hull motion information is input from the Satellite Compass™, the heave sensor compensation function cannot be used.

**Note 2:** If the [External KP] setting is set to [On] in the [Transducer] menu, the heave sensor compensation function cannot be used (FCV-800 only).

**Note 3:** Use of NMEA data converter (NMEA0183 to NMEA2000) is not recommended.

**Note 4:** Make sure to set the position of the Satellite Compass™ and transducer. Failure will result in inefficient performance.

**Note 5:** To use the heave sensor compensation function, set the output data of the Satellite Compass™ as follows. For details, refer to the desired Operator’s manual.

	NMEA0183	NMEA2000
Output sentence	ATT (GPatt), HVE (GPhve)	-
Baudrate	38,400bps	-
Output cycle	Lower than 25ms	-
Version	IEC ED1 (SC-50/110 only)	-
PGN	-	Heave: 65280 Attitude: 127257

1. Press the **MENU/ESC** key to show the main menu.
2. Select [Calib] and press the **KNOB**.
3. Select [Heave Sensor Setting] and press the **KNOB**.

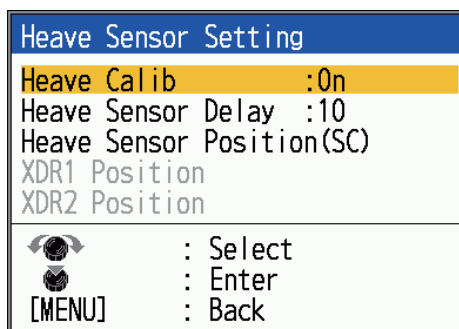

Example of FCV-800 display

4. Select [Heave Calib] and press the **KNOB**.
5. To use the heaving compensation function, select [On] and press the **KNOB**. When set to [On], the shape of the seabed will be displayed stably even in rough sea conditions.

6. Select [Heave Sensor Position (SC)] and press the **KNOB**.

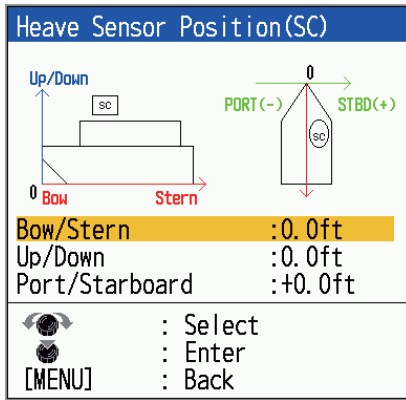

SC: Satellite Compass™

Up/Down: Height of the Satellite Compass™

(Standard point: Ship bottom)

Bow/Stern: Bow and stern direction of the

Satellite Compass™ (Standard point: bow)

Port/STBD: Left/right direction of the Satellite Compass™

(Standard point: Ship centerline)

7. See the figure above to enter the Satellite Compass™ location information. Set the Satellite Compass™ position ([Bow/Stern] [Up/Down] [Port/Starboard]) as measured from the standard point ("0"). Port is "-" and starboard is "+".
8. If the seabed is not displayed stably even when position is set correctly, select [Heave Sensor Delay] and press the **KNOB**.
9. Set the delay value and press the **KNOB**.  
Recommended setting value is 10ms. See the window when adjusting the value.
10. Press the **MENU/ESC** key to return to the [Heave Sensor Setting] window.
11. Select [XDR Position] (FCV-600) or [XDR1 Position] (FCV-800) and press the **KNOB**.

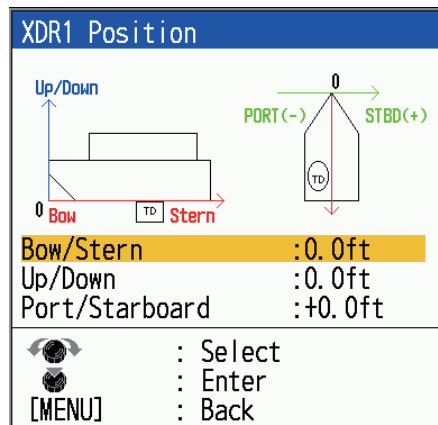

TD: Transducer

Up/Down: Height of the transducer

12. See the figure above to enter the location information of the transducer connected to the [XDR] (FCV-600) or [XDR1] (FCV-800) port. Set the position of the transducer ([Bow/Stern] [Up/Down] [Port/Starboard]) as measured from the reference point ("0"). Port is "-" and starboard is "+".

If you have a transducer connected to the [XDR2] (FCV-800) port, carry out [XDR2 Position] setting procedure same as explained above.

13. Press the **MENU/ESC** key twice to close the menu.



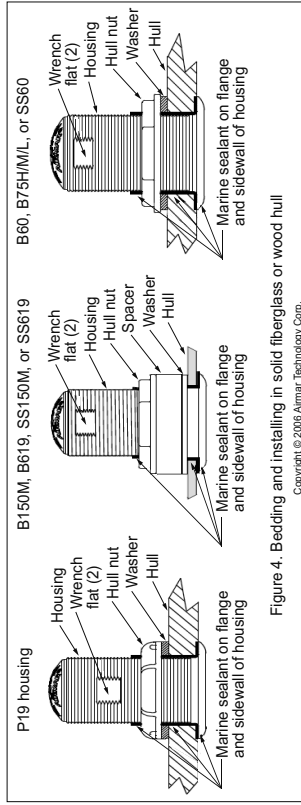

Figure 4. Bedding and installing in solid fiberglass or wood hull

Copyright © 2006 Airmar Technology Corp.

**Stainless steel housing in a metal hull** - To prevent electrolytic corrosion, the stainless steel housing must be isolated from the metal hull. Slide the isolation bushing onto the housing (see Figure 5). Apply additional marine sealant to the surfaces of the bushing that will contact the hull, filling any cavities in and around the isolation bushing.

**Installing**

- From outside the hull, thread the cable through the mounting hole. Push the housing into the mounting hole using a twisting motion to squeeze out excess sealant.
- 12" and 20" models** - From inside the hull, point the arrow on the top of the transducer (and the cable exit) toward the KEEL or centerline of the boat (see Figure 1). This will align the angle of the element inside the transducer with the deadrise angle of your hull.
- Slide the washer onto the housing (see Figure 4 or 5).
- B150M, B619, SS150M, SS619** - Also slide the spacer onto the housing and rest it against the washer. Do not use the spacer if there is insufficient space to tighten the nut or it is within 11 mm (1/2") of the top of the housing.
- Stainless steel housing in a metal hull** - Be sure the washer contacts the hull. Do not tighten the hull nut with the washer against the isolation bushing, as the housing will not be firmly installed. If necessary, sand the isolation bushing until the washer rests against the hull.
- Screw the hull nut in place.
- Plastic housing** - Do not clamp tightly on the wrench flats to avoid possibly fracturing the housing.

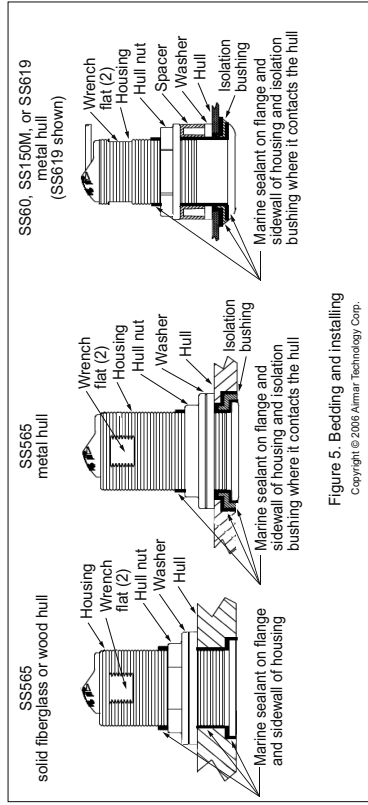

Figure 5. Bedding and installing

Copyright © 2006 Airmar Technology Corp.

- Sand and clean the area around the hole, inside and outside, to ensure that the marine sealant will adhere properly to the hull. If there is any petroleum residue inside the hull, remove it with either mild household detergent or a weak solvent (alcohol) before sanding.
- Proceed with "Bedding" on page AP-2.

**Maintenance & Replacement Anti-fouling Paint**

Surfaces exposed to salt water must be coated with anti-fouling paint. Use water-based anti-fouling paint only. Never use ketone-based paint, since ketones can attack many plastics possibly damaging the transducer. Reapply anti-fouling paint every 6 months or at the beginning of each boating season.

**Cleaning**

Aquatic growth can accumulate rapidly on the transducer's face, reducing its performance within weeks. Clean the surface with a Scotch-Brite® scour pad and mild household detergent, being careful to avoid making scratches. If the fouling is severe, lightly wet sand it with fine grade wet/dry paper.

**Replacement Transducer & Parts**

The information needed to order a replacement transducer is printed on the cable tag. Do not remove this tag. When ordering, specify the part number, date, and frequency in kHz. For convenient reference, record this information on the top of page AP-1.

Lost, broken, and worn parts should be replaced immediately.

Model	Hull Nut	Washer	Spacer	Isolation Bushing
P19	04-004	09-452	-	-
B60	02-133-01	09-813-01	-	-
B75H/M/L	02-143-01	09-1012-01	-	-
B150M B619	02-030	09-452	04-846-01	-
SS60	02-563-01	09-813-01	-	04-660-01
SS150M SS619	02-520-02	09-452	04-846-01	04-186-1
SS565	02-563-01	09-813-01	-	04-589-01

Obtain parts from your instrument manufacturer or marine dealer.

Gemeco (USA)  
Tel:803-693-0777  
Fax:803-693-0477  
email:sales@gemeco.com

Airmar EMEA (Europe, Middle East, Africa)  
Tel:+33(0)2323.52.06.48  
Fax:+33(0)2323.52.06.49  
email:sales@airmar-emea.com

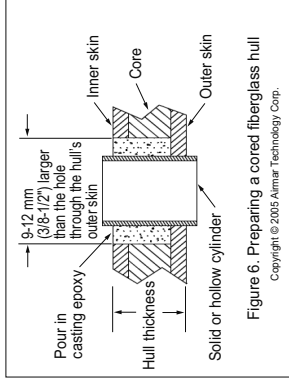

Figure 6. Preparing a cored fiberglass hull

Copyright © 2005 Airmar Technology Corp.

**Checking for Leaks**

When the boat is placed in the water, immediately check around the transducer for leaks. Note that very small leaks may not be readily observed. Do not leave the boat in the water for more than 3 hours before checking it again. If there is a small leak, there may be considerable bilge water accumulation after 24 hours. If a leak is observed, repeat "Bedding" and "Installing" immediately (see pages AP-2 to AP-3).

**Installation in a Cored Fiberglass Hull**

The core (wood or foam) must be cut and sealed carefully. The core must be protected from water seepage, and the hull must be reinforced to prevent it from crushing under the hull nut allowing the housing to become loose. **CAUTION:** Completely seal the hull to prevent water seepage into the core.

- Drill a 3 mm or 1/8" pilot hole from inside the hull (see Figure 6). If there is a rib, strut, or other hull irregularity near the selected mounting location, drill from the outside. (If the hole is drilled in the wrong location, drill a second hole in a better location. Apply masking tape to the outside of the hull over the incorrect hole and fill it with epoxy.)
- Using the appropriate size outside hull hole saw, cut a hole from outside the hull through the outer skin only (see table on page AP-2).
- From inside the hull, using the appropriate size hull interior hole saw, cut through the inner skin and most of the core. The core material can be very soft. Apply only light pressure to the hole saw after cutting through the inner skin to avoid accidentally cutting the outer skin.
- Remove the plug of core material, so the inside of the outer skin and the inner core of the hull is fully exposed. Sand and clean the inner skin, core, and the outer skin around the hole.
- If you are skilled with fiberglass, saturate a layer of fiberglass cloth with a suitable resin and lay it inside the hole to seal and strengthen the core. Add layers until the hole is the correct diameter. Alternatively, a hollow or solid cylinder of the correct diameter can be coated with wax and taped in place. Fill the gap between the cylinder and hull with casting epoxy. After the epoxy has set, remove the cylinder.

# APPX. 2 INSTALLATION OF 525STID-MSD

The installation instructions in this chapter are copied from the manufacturer's (AIRMAR® Technology Corporation) installation guide. The optional transducer (speed/temperature sensor) 525STID-MSD corresponds to B744V. The model numbers mentioned within the documentation should be read as follows:

- Thru-Hull  
**TRIDUCER** Multisensors: B744V, B744VL  
 Retractable with Valve  
**Chirp Transducers:** B765LH, B765LM, B785M

Patent <http://www.airmar.com/patent.html>

Follow the precautions for optimal product performance and to reduce the risk of property damage, personal injury, and/or death.

**WARNING:** A High-Performance Faring must be installed following the installation instructions that accompany the faring. A High-Performance Faring requires an anti-rotation bolt to keep the faring from turning while the boat is underway.

**WARNING:** Always wear safety glasses, a dust mask, and ear protection when installing.

**WARNING:** Immediately check for leaks when the boat is placed in the water. Do not leave the boat unattended for more than three hours. Even a small leak may allow considerable water to accumulate.

**WARNING:** B744V, B744VL — The valve is not a watertight seal! Always install the paddlewheel in sert or the blanking plug secured with the insert nut and safety wire for a watertight seal.

**WARNING:** B744V, B744VL — The O-rings must be intact and well lubricated to make a watertight seal.

**WARNING:** B744V, B744VL — Always attach the safety wire to prevent the insert nut from backing out in the unlikely event that the cap nut and/or insert nut fails or is screwed on incorrectly.

**WARNING:** B744V, B744VL — Do not remove the CAP nut. The valve assembly will come out. The insert/blanking plug cannot be secured without the valve assembly.

**CAUTION:** Always operate the transducer in water. Operating in air will allow the transducer to overheat resulting in failure.

**CAUTION:** Never mount a bronze housing in a metal hull because electrolytic corrosion will occur.

**CAUTION:** Never install a metal housing in a vessel with a positive ground system.

**CAUTION:** Never, pull, carry, or hold the sensor by its cable. This may sever internal connections.

**CAUTION:** Never strike the sensor.

**CAUTION:** Never use solvents, cleaner, fuel, sealant, paint and other products may contain solvents that can damage plastic parts, especially the transducer's face.

**IMPORTANT:** The sensor must be installed carefully. Read the instructions completely before proceeding with the installation. These instructions supersede any other instructions in your instrument manual if they differ.

## WARNING

The sensor must be installed with a High-Performance Faring!

A faring that is carefully cut to fit the shape of the hull provides a sealing surface around the drilled hole. If the sensor is not installed with a faring, there may be insufficient surface area to seal the hull. Water may leak into the boat causing damage or possibly sinking.

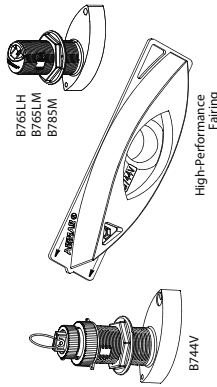

## Applications

Bronze sensor recommended for fiberglass or wood hulls only.

## Tools & Materials

High-Performance Faring (MANDATORY)

Safety glasses

Dust mask

Ear protection

Grommet(s) (some installations)

Cable ties

Water-based anti-fouling paint (mandatory in salt water)

## Identify Your Model

The model name is printed on the cable tag.

**Pretest:** B744V, B744VL

Connect the multisensor to the instrument and spin the paddlewheel. Check for a speed reading and the approximate air temperature. If there is no reading or it is inaccurate, check the connections and repeat the test. If there is still no reading or they are inaccurate, return the product to the place of purchase.

Record the information found on the cable tag for future reference.

Part No. \_\_\_\_\_ Date \_\_\_\_\_ Frequency \_\_\_\_\_ kHz

## APPX. 2 INSTALLATION OF 525STID-MSD

### Boat Types (Figure 1)

- **Displacement hull powerboat** —Locate 1/3 of the way along the LWL and 150–300mm (6–12") off the centerline. The side of the hull where the propeller blades are moving downward is preferred.
- **Planing hull powerboat** —Mount well aft near the centerline and well inboard of the first set of lifting strakes; to ensure that it is in contact with the water at high speeds. The side of the hull where the propeller blades are moving downward is preferred.
- **Outboard and/O** —Mount forward and to the side of the engine(s).
- **Stepped hull** —Mount just ahead of the propeller(s) and shaft(s).
- **Boats capable of speeds above 25 kn (29MPH)** —Review sensor location and operating results of similar boats before proceeding.
- **Fin keel sailboats** —Mount to the side of the centerline and forward of the fin keel 300–600mm (1–2).
- **Full keel sailboats** —Locate amidships and away from the keel at the point of minimum deadrise angle.

### Installation : B744V, B744VL

#### Installing the Cap Nut

**CAUTION :** Avoid cross threading the CAP nut.

Being sure the valve assembly is seated firmly within the housing, carefully screw the CAP nut in place (Figure 2). Hand-tighten only. Do not over tighten.

#### Installing the Paddlewheel Insert

1. After the sealant cures, inspect the O-rings on the paddlewheel insert (replace if necessary) and lubricate them with the silicone lubricant supplied (Figure 3). The O-rings must be intact and well lubricated to make a watertight seal.

2. Slide the paddlewheel insert into the housing with the arrow on the top pointing forward toward the bow. Seat it into place using a twisting motion until the keys fit into the notches. (The insert fits one way only.) Be careful not to rotate the outer housing and disturb the sealant. Screw the INSERT nut in place and hand-tighten only. Do not over tighten.

3. Attach the safety wire to prevent the insert from backing out in the unlikely event that the cap nut and/or insert nut fails or is screwed on incorrectly. Wrap one end of the safety wire tightly around the stem of the housing and twist it together with the long end (Figure 2). Keeping the wire taut throughout, lead the wire straight up and through one eye in the CAP nut. Thread the wire through the eye a second time. Lead the wire in a counterclockwise direction and thread it through the eye in the INSERT nut. Thread the wire through that eye a second time. Loop the wire through the pull ring and twist the wire securely to itself.

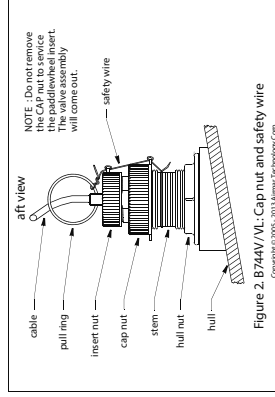

Figure 2. B744V/VL Cap nut and safety wire

Copyright © 2002, 2010 Airmar Technology Corp.

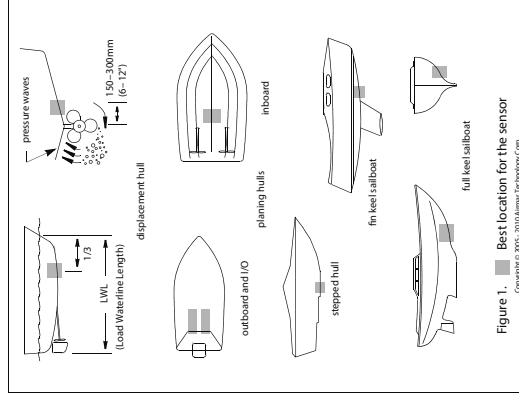

Figure 1. Best location for the sensor

Copyright © 2002, 2010 Airmar Technology Corp.

### Mounting Location Guidelines

**CAUTION :** Do not mount the sensor in line with or near water intake or discharge openings or behind strakes, fittings, or hull irregularities that will disturb the water flow.

**CAUTION :** Do not mount the sensor where the boat may be supported during trailering, launching, hauling, or storage to avoid damaging the transducer's face.

- The water flowing under the hull must be smooth with a minimum of bubbles and turbulence (especially at high speeds).
  - The sensor must be continuously immersed in water.
  - The transducer beam must be unobstructed by the keel or propeller shaft(s).
  - Choose a location away from interference caused by power and radiation sources such as the propeller(s) and shaft(s), other machinery, other echosounders, and other cables. The lower the noise level, the higher the echosounder gain setting that can be used.
  - Choose a location with a minimum deadrise angle.
  - Choose an accessible spot inside the vessel with adequate headroom for the height of the housing, tightening the nuts), and installing any insert.
- | Model  | Min. with fairing |
|--------|-------------------|
| B744V  | 255mm (10")       |
| B744VL | 381mm (15")       |
- **Chirp transducer** —Mount in a cool well-ventilated area away from the engine to avoid overheating.

**Cable Routing & Connecting**

**CAUTION:** If the sensor came with a connector, do not remove it to ease cable routing. If the cable must be cut and spliced, use Airmar's splash-proof Junction Box No. 33-035 and follow the instructions supplied. Removing the waterproof connector or cutting the cable, except when using a water-tight junction box, will void the sensor warranty.

1. Route the cable to the instrument, being careful not to tear the cable jacket when passing it through the bulkheads) and other parts of the boat. Use grommets to prevent chafing. To reduce electrical interference, separate the sensor cable from other electrical wiring and the engine. Coil any excess cable and secure it in place using cable ties to prevent damage.
2. Refer to the echosounder owner's manual to connect the sensor to the instrument.

**Check for Leaks**

When the boat is placed in the water, immediately check around the sensor for leaks. Note that very small leaks may not be readily observed. Do not leave the boat in the water for more than 3 hours before checking it again. If there is a small leak, there may be considered a minor occurrence after 24 hours. If a leak is observed, repeat the following steps immediately (High-Performance Fairing Installation Instructions).

**Operation & Maintenance**

**Anti-fouling Paint**

Surfaces exposed to salt water must be coated with anti-fouling paint. Use water-based anti-fouling paint only. Never use ketone-based paint since ketones can attack many plastics possibly damaging the transducer. Reapply paint every 6 months or at the beginning of each boating season.

- B744V/VL** —Paint the following surfaces (Figure 4).
- Exposed areas of the housing including the transducer's face
  - Bore of the housing up 30mm (1-1/4")
  - Outside wall of the paddlewheel insert below the lower O-ring
  - Paddlewheel cavity
  - Paddlewheel
  - Blanking plug below the lower O-ring including the exposed end

**Cleaning the Sensor**

Aquatic growth can accumulate rapidly on the sensor's surface, affecting its performance. Clean the sensor's surface with mild household detergent and a Scotch-Brite® scour pad. **B744V/VL** —If fouling on the insert is severe, push out the paddlewheel shaft using a spare shaft or a 4-D finish nail with a flattened point. Then lightly wet sand the paddlewheel with fine grade wet/dry paper.

**How the Valve Works: B744V/VL**

**WARNING:** The valve is not a watertight seal. Always install the paddlewheel insert or the blanking plug secured with the INSERT nut and safety wire for a watertight seal.

The multisensor incorporates a self-closing valve which minimizes the flow of water into the vessel when the paddlewheel insert is removed (Figure 3). The curved flap valve is activated by both a spring and water pressure. Water pushes the flap valve upward to block the opening, so there is no gush of water into the boat.

**Using the Blanking Plug: B744V/VL**

- To protect the paddlewheel, use the blanking plug:
- When the boat will be kept in salt water for more than a week.
  - When the boat will be removed from the water.
  - When aquatic growth buildup on the paddlewheel is suspected due to inaccurate readings from the instrument.

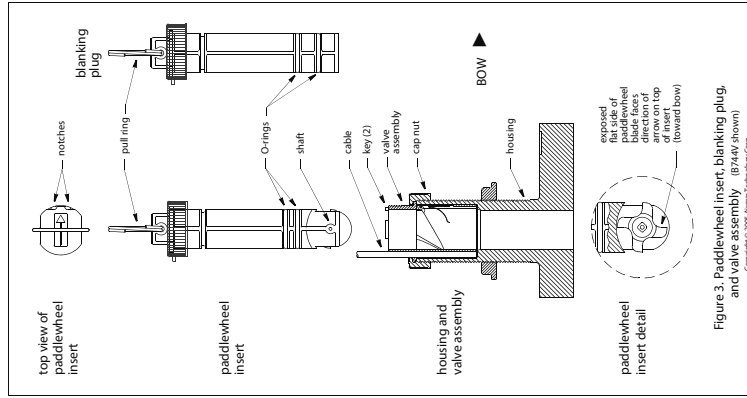

Figure 3. Paddlewheel insert, blanking plug, and valve assembly (B744V/VL shown)

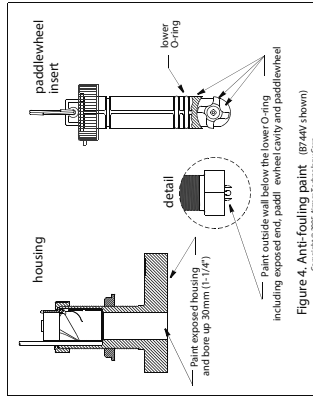

Figure 4. Anti-fouling paint (B744V/VL shown)

1. On the blanking plug, inspect the O-rings (replace if necessary) and lubricate them with silicone lubricant or petroleum jelly (Vaseline®) (Figure 3). The O-rings must be intact and well lubricated to make a watertight seal.
  2. Remove the paddlewheel insert from the housing by removing the safety wire from the pull ring and the INSERT nut (Figure 2). Unscrew the INSERT nut. Do not remove the CAP nut, as the valve assembly will come out.
  3. Grasp the pull ring and remove the paddlewheel insert with a slow pulling motion.
- NOTE:** In the unlikely event that the paddlewheel insert cannot be removed, see "Servicing the Valve Assembly" below.
4. Slide the blanking plug into the housing. Seat it into place with a pushing twisting motion until the keys fit into the notches (Figure 3). Screw the INSERT nut in place and hand-tighten only. Do not over tighten.
  5. Reattach the safety wire (Figure 2).

**Servicing the Valve Assembly: B744V/VL**

**WARNING:** The insert/blanking plug cannot be secured without the valve sleeve. When the valve assembly is removed, always reinsert the valve sleeve secured with the CAP nut and the insert/blanking plug secured with the INSERT nut and safety wire for a watertight seal.

**CAUTION:** Be careful to avoid cross threading the CAP nut. Should the valve fail, it will need to be removed for servicing. Follow the steps below. If a key is missing, a key must be made not immediately available. The valve sleeve must be installed in the multisensor housing for a watertight seal. Remove the flap valve, spring pin, and spring from the sleeve (Figure 5). Then reinstall the sleeve in the housing.

1. On the blanking plug, inspect the O-rings (replace if necessary) and lubricate them with silicone lubricant or petroleum jelly (Figure 3). The O-rings must be intact and well lubricated to make a watertight seal.
2. Remove the safety wire and unscrew the CAP nut (Figure 2). With the blanking plug ready in one hand, remove the paddlewheel insert valve assembly in the other hand by grasping the pull ring. The valve assembly is now ready to be inserted into the boat. Temporarily secure it with the safety wire. Do not leave the boat in the water unattended. This is not a watertight or secure seal.

3. Separate the paddlewheel insert from the valve assembly by unscrewing the INSERT nut (Figure 3). Grasp the pull ring and pull slowly upward.
4. Clean, repair, or replace the valve assembly, so the flap valve moves freely and seats against the sleeve (Figure 5).
5. To reinstall the valve assembly, inspect the O-rings on the paddlewheel insert (replace if necessary) and lubricate them with silicone lubricant or petroleum jelly (Figure 3). The O-rings must be intact and well lubricated to make a watertight seal.

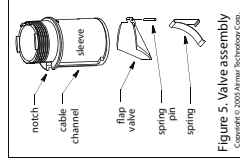

Figure 5. Valve assembly (Copyright © 2008 Airmar Technology Corp.)

6. Slide the paddlewheel insert into the valve assembly. Seat it in place with a twisting motion until the keys fit into the notches. Secure the paddlewheel insert with the INSERT nut. Hand-tighten only. Do not over tighten.
  7. Remove the safety wire from the multisensor. With the combined valve assembly and paddlewheel insert ready in one hand, remove the blanking plug. Slide the assembly into the multisensor housing with the arrow on the top pointing forward toward the bow. Be sure the cable fits into the cable channel and the notch in the sleeve fits into the key in the housing (Figure 5). (A pushing twisting motion will locate the key.)
- Screw the CAP nut in place, being careful to avoid cross-threading. Hand-tighten only. Do not over tighten.
8. Reattach the safety wire (Figure 2).

**Servicing the Paddlewheel Insert: B744V/VL**

The water lubricated paddlewheel bearings have a life of up to 5 years on low-speed boats (less than 10kn (11MPH)) and 1 year on high-speed vessels. Paddlewheels can fracture and shafts can bend due to impact with water borne objects and mishandling in boat yards. O-rings must be free of abrasions and cuts to ensure a watertight seal.

1. Using the new paddlewheel shaft, push out the old shaft about 6mm (1/4"). With pliers, remove the old shaft (Figure 3).
2. Place the new paddlewheel in the cavity with the flat side of the blade facing the same direction as the arrow on the top of the insert.
3. Tap in the new shaft into place until the ends are flush with the sides of the insert.
4. Install two O-rings in the lower grooves near the paddlewheel. Do not place them near the pull ring.
5. The remaining two O-rings are placed in a similar position on the blanking plug.
6. Reinstall the paddlewheel insert, see "Installing the Paddlewheel Insert" (page 2).

**Winterizing: B744V/VL**

After the boat has been hauled for winter storage, remove the blanking plug to let the water drain away before reinserting it. This will prevent any water from freezing around the blanking plug and possibly cracking it.

**Replacement Sensor & Parts**

The information needed to order a replacement Airmar sensor is printed on the cable tag. Do not remove this tag. When ordering, specify the part number, date, and frequency in kHz. For convenient reference, record this information at the bottom of page one.

Lost, broken, and worn parts should be replaced immediately. Obtain parts from your instrument manufacturer or marine dealer.

Gemsecos

USA

Tel: 803-693-0777

email: sales@gemsecos.com

Europe, Middle East, Africa

Tel: +331(0)2232320648

email: sales@airmar-emea.com



**AIRMAR**<sup>®</sup>  
TECHNOLOGY CORPORATION  
35 Meadowbrook Drive, Milford, New Hampshire 03055-4613, USA  
www.airmar.com



Copyright © 2004 2018 Airmar Technology Corp. All rights reserved.

PACKING LIST

02HB-X-9851 -0 1/1

FCV-800-E/J

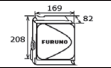
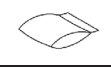
A-1

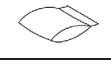
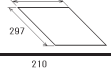
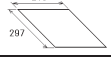
NAME	UNIT	OUTLINE	DESCRIPTION/CODE No.	Q'TY
ユニット FISH FINDER			FCV-800 999-999-666-10	1 (*1)
予備品 SPARE PARTS			SPO2-07001 999-999-777-10	1 (*)
付属品 ACCESSORIES			FPO3-11601 001-134-680-00	1
工事材料 INSTALLATION MATERIALS			CPO2-10001 999-999-888-10	1 (*)
図書 DOCUMENT				
装備要領書(英) INSTALLATION MANUAL (EN)			IME-23940-* 000-199-646-1*	1
装備要領書(和) INSTALLATION MANUAL (JP)			IMJ-23940-* 000-199-645-1*	1

(\*)は、ダミーコードに付き、注文できません。  
(\* THIS CODE CANNOT BE ORDERED.

(略図の寸法は、参考値です。 DIMENSIONS IN DRAWING FOR REFERENCE ONLY.)

CN



C2394-Z01-A

PACKING LIST

02HB-X-9852 -1 1/1

FCV-800-E/J

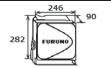
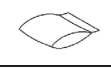
A-2

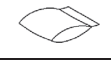
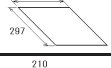
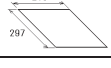
NAME	UNIT	OUTLINE	DESCRIPTION/CODE No.	Q'TY
ユニット FISH FINDER			FCV-800 999-999-666-20	1 (*1)
予備品 SPARE PARTS			SPO2-07001 999-999-777-10	1 (*1)
付属品 ACCESSORIES			FPO3-11601 001-134-680-00	1
工事材料 INSTALLATION MATERIALS			CPO2-10101 999-999-888-20	1 (*)
図書 DOCUMENT				
装備時のご注意 NOTICE FOR INSTALLATION			*22-02302-* 00020056*1*	1
装備要領書 INSTALLATION MANUAL			IME-23940-* 00019964*1*	1

(\*)は、ダミーコードに付き、注文できません。  
(\* THIS CODE CANNOT BE ORDERED.

(略図の寸法は、参考値です。 DIMENSIONS IN DRAWING FOR REFERENCE ONLY.)

CN



C2395-Z01-B

PACKING LIST

02HB-X-9855 -0 1/1

FCV-800-E-MIK

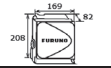
A-3

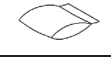
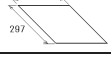
NAME	UNIT	OUTLINE	DESCRIPTION/CODE No.	Q'TY
ユニット FISH FINDER			FCV-800 999-999-666-10	1 (*)
予備品 SPARE PARTS			SPO2-07001 999-999-777-10	1 (*)
付属品 ACCESSORIES			FPO3-11601 001-134-680-00	1
工事材料 INSTALLATION MATERIALS			CPO2-10001 999-999-888-10	1 (*)
図書 DOCUMENT				
装備要領書(英) INSTALLATION MANUAL (EN)			IME-23940-* 000-200-943-1*	1

(\*)は、ダミーコードに付き、注文できません。  
(\* THIS CODE CANNOT BE ORDERED.

(略図の寸法は、参考値です。 DIMENSIONS IN DRAWING FOR REFERENCE ONLY.)

KR





C2394-Z03-A

PACKING LIST

02HB-X-9856 -0 1/1

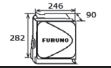
FCV-800-E-MIK

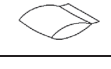
A-4

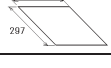
NAME	UNIT	OUTLINE	DESCRIPTION/CODE No.	Q'TY
ユニット FISH FINDER			FCV-800 999-999-666-20	1 (*)
予備品 SPARE PARTS			SPO2-07001 999-999-777-10	1 (*)
付属品 ACCESSORIES			FPO3-11601 001-134-680-00	1
工事材料 INSTALLATION MATERIALS			CPO2-10101 999-999-888-20	1 (*)
図書 DOCUMENT				
装備時のご注意 NOTICE FOR INSTALLATION			E22-02302-* 000-200-944-1*	1
装備要領書(英) INSTALLATION MANUAL (EN)			IME-23940-* 000-200-943-1*	1

(\*)は、ダミーコードに付き、注文できません。  
(\* THIS CODE CANNOT BE ORDERED.

(略図の寸法は、参考値です。 DIMENSIONS IN DRAWING FOR REFERENCE ONLY.)

KR

C2395-Z03-A



表1 TABLE 1

寸法区分 (mm) DIMENSION	公差 (mm) TOLERANCE
L ≤ 50	±1.5
50 < L ≤ 100	±2.5
100 < L ≤ 500	±3

取付穴  
4-φ7  
FIXING HOLES

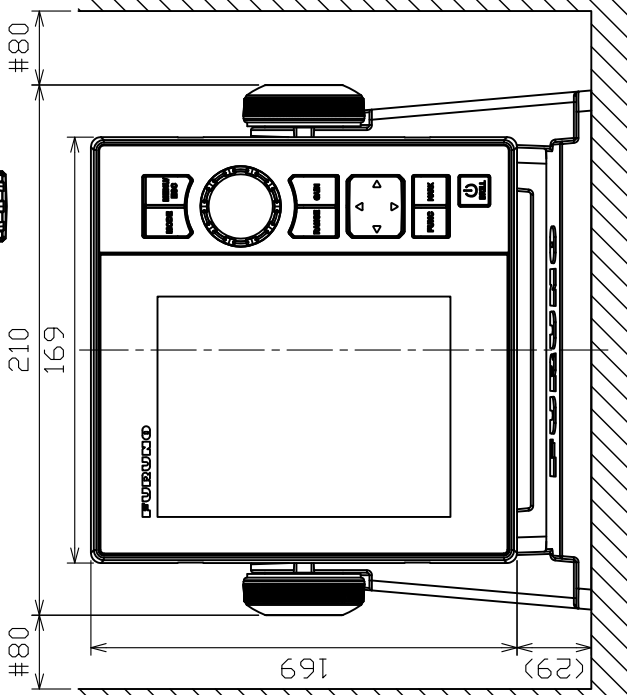
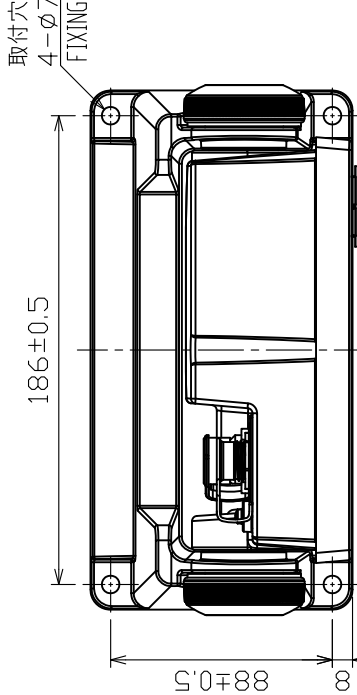
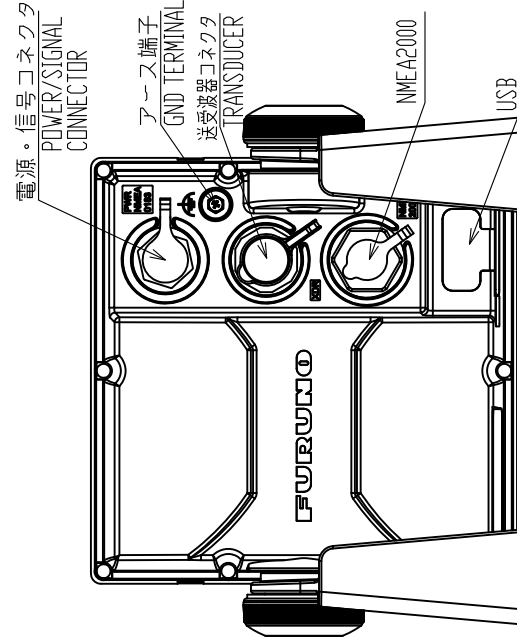
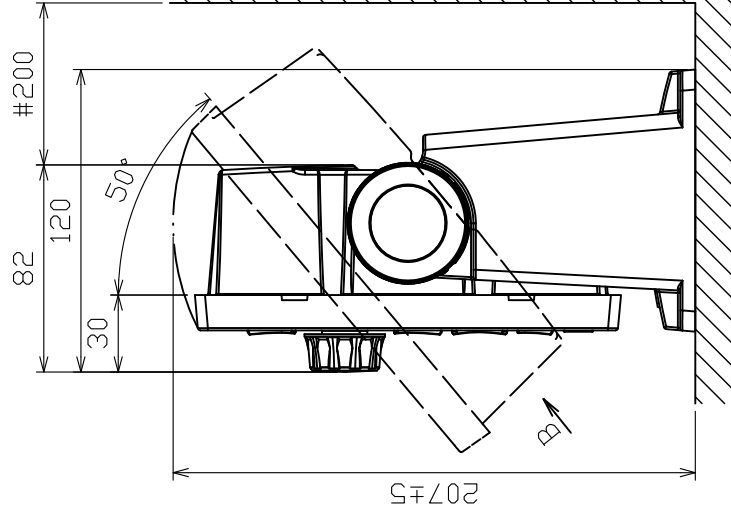
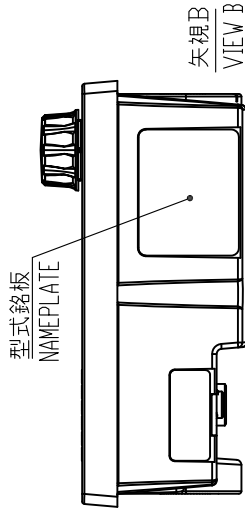

注記

- 1) 指定外の寸法公差は表1による。
- 2) 印寸法は最小サービス空間寸法とする。
- 3) 取付ネジは+トラスタッピンネジ呼び径5×20を使用のこと。

NOTE

1. TABLE 1 INDICATES TOLERANCE OF DIMENSIONS WHICH IS NOT SPECIFIED.
2. #: MINIMUM SERVICE CLEARANCE.
3. USE TAPPING SCREWS φ5x20 FOR FIXING THE UNIT.

DRAWN	1/Nov/2022	I. YAMASAKI	TITLE	FCV-600
CHECKED	1/Nov/2022	H. MAKI	名称	カラーLCD魚探 (卓上装備)
APPROVED	14/Dec/2022	H. MAKI	外寸図	FCV-600
SCALE	1/3	MASS 1.3 kg	NAME	FISH FINDER (TABLETOP MOUNT)
DWG. No.	C2394-G01-A	REF. No.	02-181-100G-2	OUTLINE DRAWING

表1 TABLE 1

寸法区分 (mm) DIMENSION	公差 (mm) TOLERANCE
L ≤ 50	±1.5
50 < L ≤ 100	±2.5
100 < L ≤ 500	±3

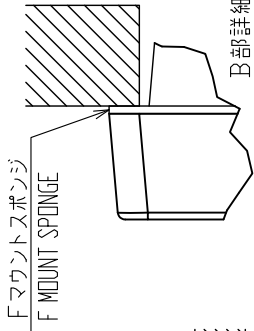

B部詳細<尺度: 1/1>  
DETAIL FOR B (SCALE: 1/1)

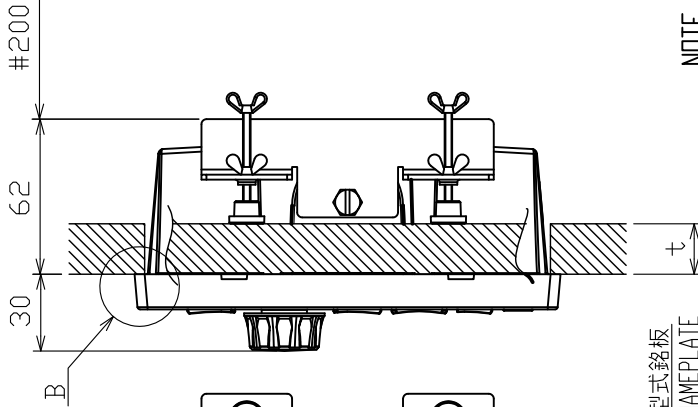
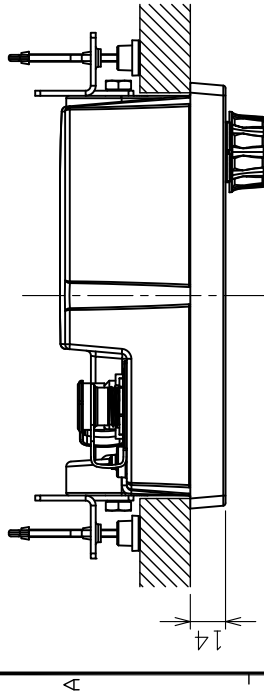

NOTE

1. TABLE INDICATES TOLERANCE OF DIMENSIONS WHICH IS NOT SPECIFIED.
2. #: MINIMUM SERVICE CLEARANCE.
3. BULKHEAD THICKNESS (t):  $3 \leq t \leq 20$ .

DRAWN	1/Nov/2022	T.YAMASAKI	TITLE	FCV-600
CHECKED	1/Nov/2022	H.MAKI	名称	カラーLCD魚探 (埋込装備)
APPROVED	14/Dec/2022	H.MAKI	外寸図	
SCALE	1/3	MASS 1.1 kg	NME	FISH FINDER (FLUSH MOUNT)
DWG.No.	C2394-G02-A	REF.No.	02-181-110G-2	OUTLINE DRAWING

注記

- 1) 指定外の寸法公差は表1による。
- 2) #印寸法は最小サービス空間寸法とする。
- 3) 壁の厚み (t) は、3以上20以下とする。

表1 TABLE 1

寸法区分 (mm) DIMENSION	公差 (mm) TOLERANCE
L ≤ 50	±1.5
50 < L ≤ 100	±2.5
100 < L ≤ 500	±3

矢視B  
VIEW B

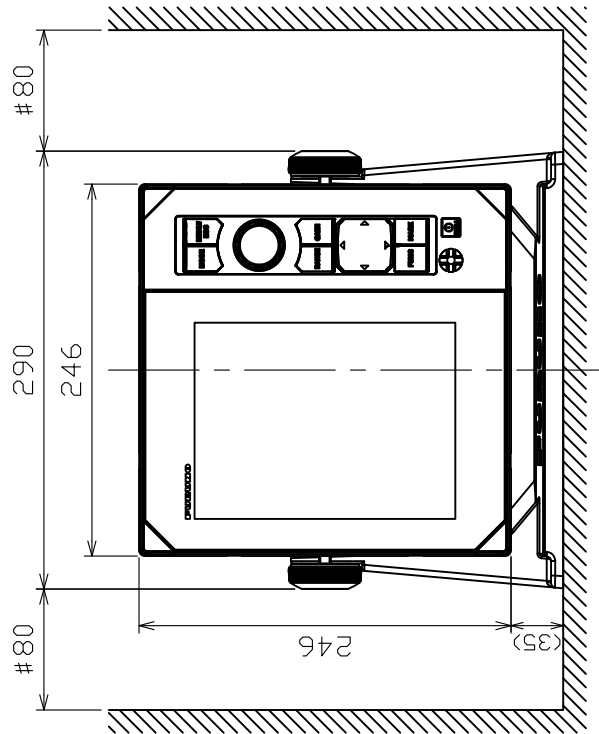
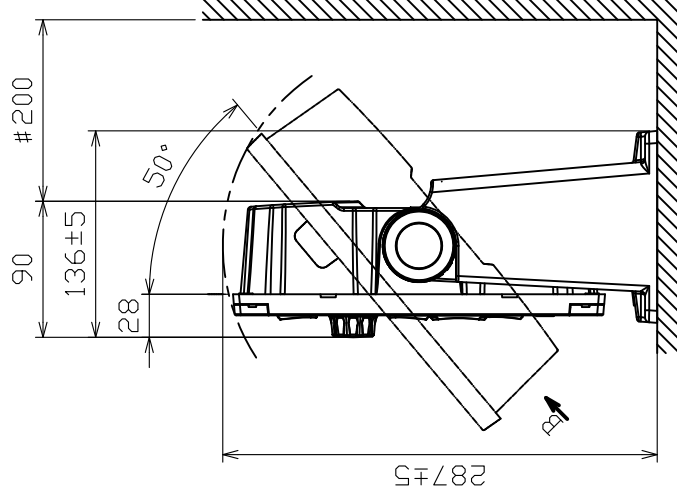
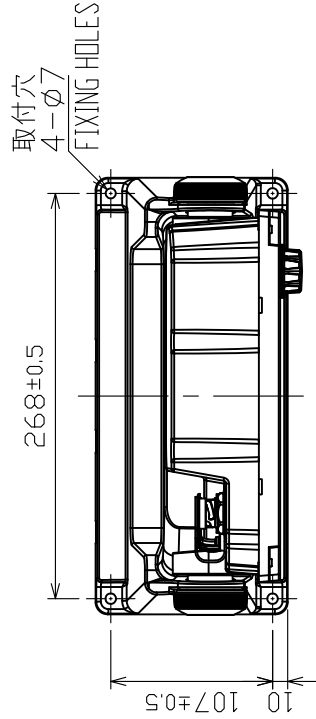
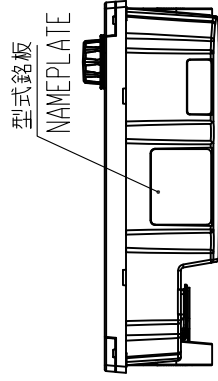

電源・信号コネクタ  
POWER/SIGNAL  
CONNECTOR  
アース端子  
GND TERMINAL  
送受波器コネクタ  
TRANSDUCER  
NMEA2000  
USB

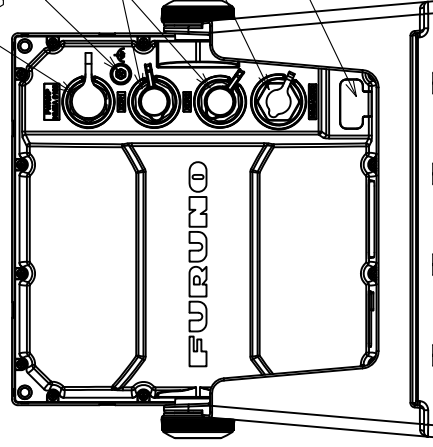

注記

- 指定なき寸法公差は表1による。
- #印寸法は最小サービスマン寸法とする。
- 取付ネジは+トラスタツピンネジ呼び径5×20を使用のこと。

NOTE

- TABLE 1 INDICATES TOLERANCE OF DIMENSIONS WHICH IS NOT SPECIFIED.
- #: MINIMUM SERVICE CLEARANCE.
- USE TAPPING SCREWS φ5×20 FOR FIXING THE UNIT.

DRAWN	1/Nov/2022	I.YAMASAKI	TITLE	FCV-800
CHECKED	1/Nov/2022	H.MAKI	名称	カラーLCD魚探 (卓上装備)
APPROVED	14/Dec/2022	H.MAKI	外寸図	
SCALE	1/5	MASS 2.4 kg	NAME	FISH FINDER (TABLETOP MOUNT)
DWG.No.	C2395-501-A	REF.No.	02-181-200G-1	OUTLINE DRAWING

表1 TABLE 1

寸法区分 (mm) DIMENSION	公差 (mm) TOLERANCE
L ≤ 50	±1.5
50 < L ≤ 100	±2.5
100 < L ≤ 500	±3

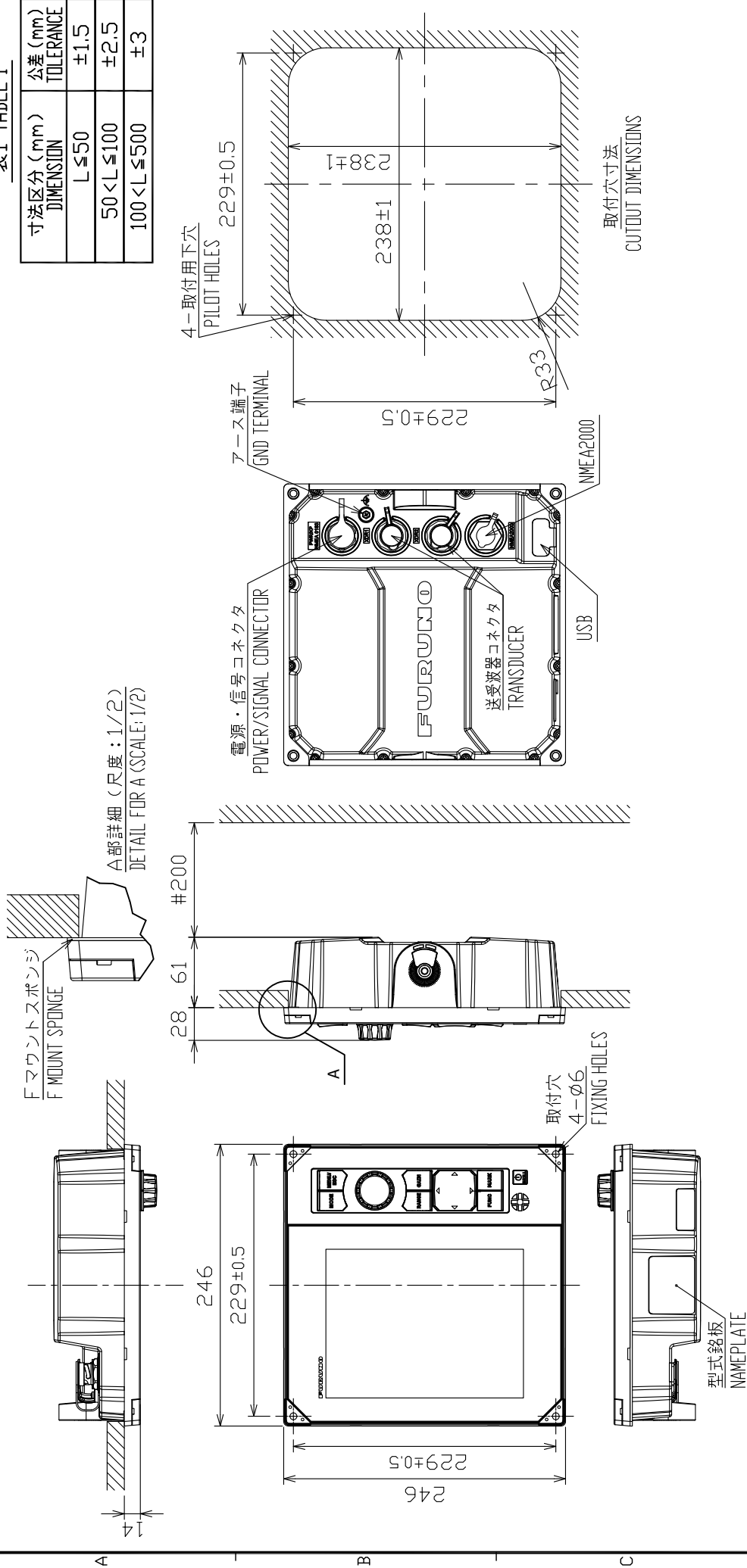

注記

- 1) 指定外の寸法公差は表1による。
- 2) #印寸法は最小サービスマウント間寸法とする。
- 3) 取付ネジは+バインドタピンネジ呼び径5×20を使用のこと。

NOTE

1. TABLE 1 INDICATES TOLERANCE OF DIMENSIONS WHICH IS NOT SPECIFIED.
2. # MINIMUM SERVICE CLEARANCE.
3. USE TAPPING SCREWS  $\phi 5 \times 20$  FOR FIXING THE UNIT.

DRAWN	1/Nov/2022	T.YAMASAKI	TITLE	FCV-800
CHECKED	1/Nov/2022	H.MAKI	名称	カラーLCD魚探 (埋込装備)
APPROVED	14/Dec/2022	H.MAKI	外寸図	
SCALE	1/5	MASS 1.8 kg	NAME	FISH FINDER (FLUSH MOUNT)
DWG.No.	C2395-G02-A	REF.No.	02-181-210G-1	OUTLINE DRAWING



表 1 TABLE 1

寸法区分 (mm) DIMENSION	公差 (mm) TOLERANCE
$L \leq 50$	$\pm 1.5$
$50 < L \leq 100$	$\pm 2.5$
$100 < L \leq 500$	$\pm 3$

- 注 記
- 1) 指定外の寸法公差は表 1 による。
  - 2) # 印寸法は最小サービス空間寸法とする。
  - 3) 取付にはタッピンネジ呼び 4 を使用のこと。

- NOTE
1. TABLE 1 INDICATES TOLERANCE OF DIMENSIONS WHICH IS NOT SPECIFIED.
  2. #: MINIMUM SERVICE CLEARANCE.
  3. USE TAPPING SCREWS  $\phi 4$  FOR FIXING THE UNIT.

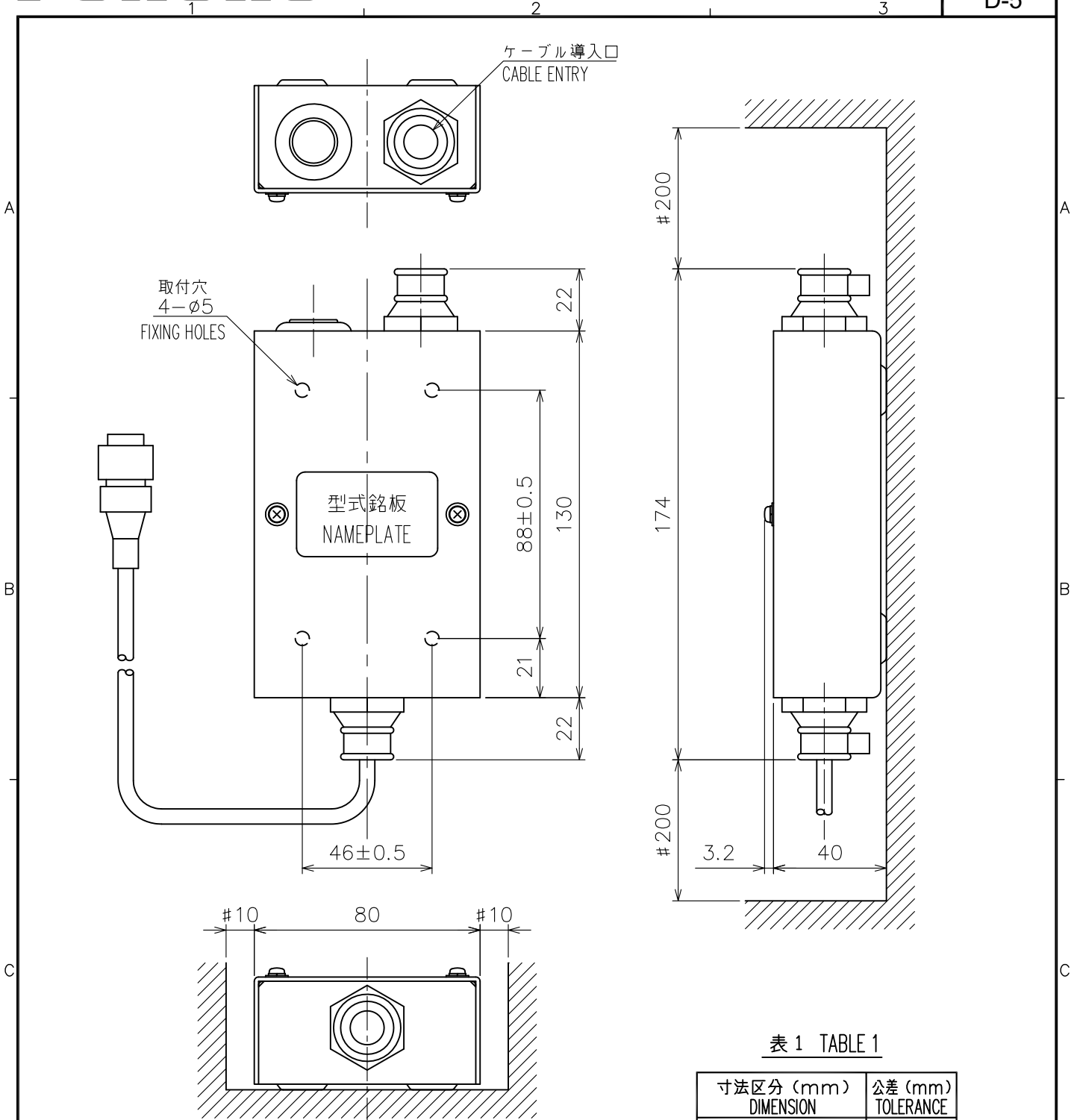
DRAWN	12/Mar/2015 T.YAMASAKI	TITLE	MB-1100
CHECKED	12/Mar/2015 H.MAKI	名称	分配箱
APPROVED	12/Mar/2015 H.MAKI		外寸図
SCALE	1/2	MASS	0.30 $\pm 10\%$ kg
			質量はケーブル (1m) を含む。 MASS INCLUDES 1m CABLE.
DWG. No.	C2375-G03-C	REF. No.	02-155-200G-2
		NAME	MATCHING BOX
			OUTLINE DRAWING

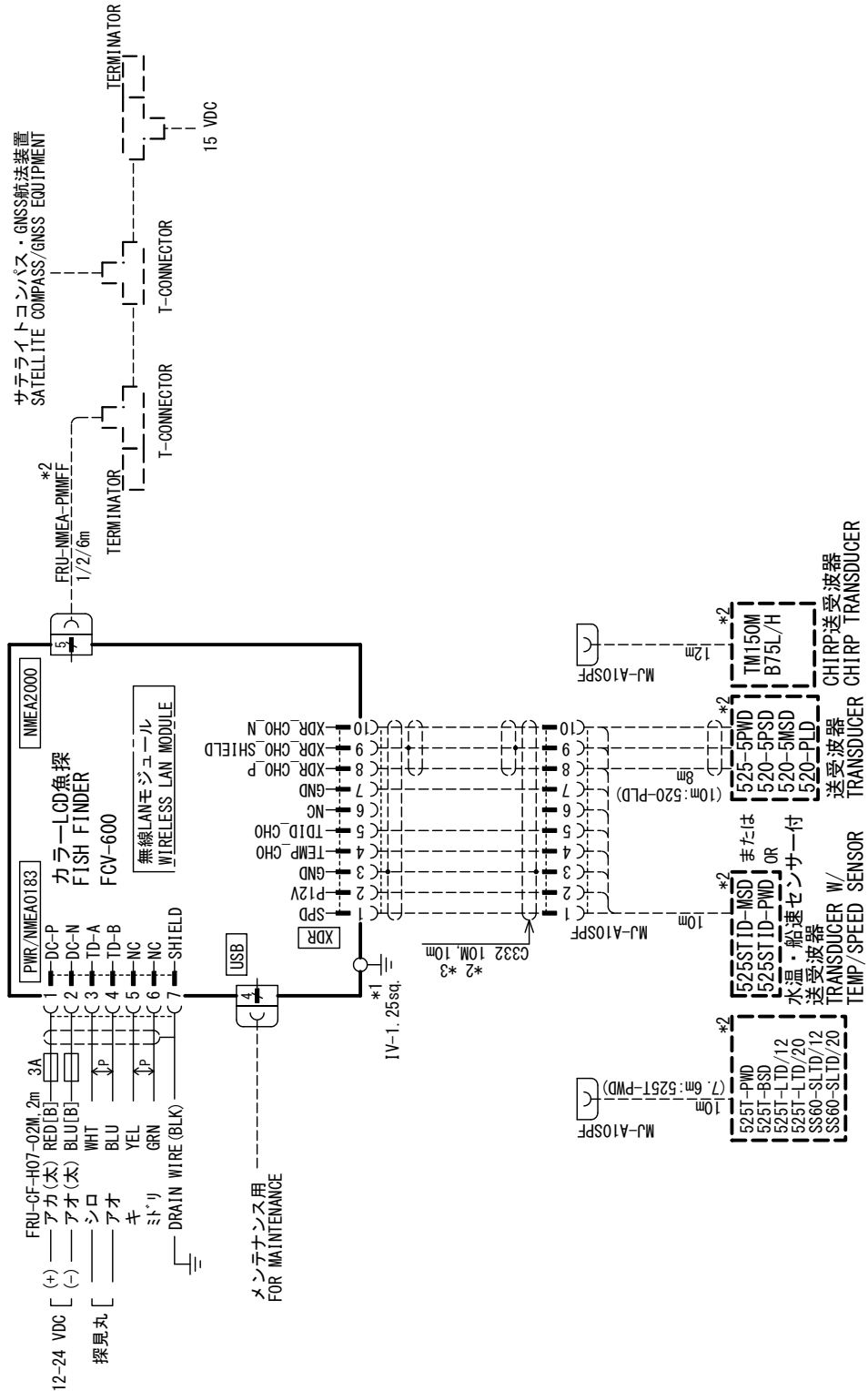

A

B

C

注記  
 \* 1) 造船所手配。  
 \* 2) オプション。  
 \* 3) ケーブル延長の場合、ACCU-FISH性能低下の恐れあり。

NOTE  
 \*1: SHIPYARD SUPPLY.  
 \*2: OPTION.  
 \*3: ACCU-FISH PERFORMANCE MAY BE DECLINED BY CABLE EXTENSION.

DRAWN 27/Oct/2022 T. YAMASAKI	TITLE FCV-600
CHECKED 27/Oct/2022 H. MAKI	名称 カラーLCD魚探
APPROVED 14/Dec/2022 H. MAKI	相互結線図
SCALE 1/ASS	NAME FISH FINDER
DWG. No. C2394-001-A	REF. No. 02-181-6211-0
INTERCONNECTION DIAGRAM	



# FURUNO Worldwide Warranty for Pleasure Boats (Except North America)

This warranty is valid for products manufactured by Furuno Electric Co. (hereafter FURUNO) and installed on a pleasure boat. Any web based purchases that are imported into other countries by anyone other than a FURUNO certified dealer may not comply with local standards. FURUNO strongly recommends against importing these products from international websites as the imported product may not work correctly and may interfere with other electronic devices. The imported product may also be in breach of the local laws and mandated technical requirements. Products imported into other countries as described previously shall not be eligible for local warranty service.

For products purchased outside of your country please contact the national distributor of Furuno products in the country where purchased.

This warranty is in addition to the customer's statutory legal rights.

## 1. Terms and Conditions of Warranty

FURUNO guarantees that each new FURUNO product is the result of quality materials and workmanship. The warranty is valid for a period of 2 years (24 months) from the date of the invoice, or the date of commissioning of the product by the installing certified dealer.

## 2. FURUNO Standard Warranty

The FURUNO standard warranty covers spare parts and labour costs associated with a warranty claim, provided that the product is returned to a FURUNO national distributor by prepaid carrier.

The FURUNO standard warranty includes:

- Repair at a FURUNO national distributor
- All spare parts for the repair
- Cost for economical shipment to customer

## 3. FURUNO Onboard Warranty

If the product was installed/commissioned and registered by a certified FURUNO dealer, the customer has the right to the onboard warranty.

The FURUNO onboard warranty includes

- Free shipping of the necessary parts
- Labour: Normal working hours only
- Travel time: Up to a maximum of two (2) hours
- Travel distance: Up to a maximum of one hundred and sixty (160) KM by car for the complete journey

## 4. Warranty Registration

For the Standard Warranty - presentation of product with serial number (8 digits serial number, 1234-5678) is sufficient. Otherwise, the invoice with serial number, name and stamp of the dealer and date of purchase is shown.

For the Onboard Warranty your FURUNO certified dealer will take care of all registrations.

## 5. Warranty Claims

For the Standard Warranty - simply send the defective product together with the invoice to a FURUNO national distributor. For the Onboard Warranty – contact a FURUNO national distributor or a certified dealer. Give the product's serial number and describe the problem as accurately as possible.

Warranty repairs carried out by companies/persons other than a FURUNO national distributor or a certified dealer is not covered by this warranty.

## 6. Warranty Limitations

When a claim is made, FURUNO has a right to choose whether to repair the product or replace it.

The FURUNO warranty is only valid if the product was correctly installed and used. Therefore, it is necessary for the customer to comply with the instructions in the handbook. Problems which result from not complying with the instruction manual are not covered by the warranty.

FURUNO is not liable for any damage caused to the vessel by using a FURUNO product.

The following are excluded from this warranty:

- a. Second-hand product
- b. Underwater unit such as transducer and hull unit
- c. Routine maintenance, alignment and calibration services.
- d. Replacement of consumable parts such as fuses, lamps, recording papers, drive belts, cables, protective covers and batteries.
- e. Magnetron and MIC with more than 1000 transmitting hours or older than 12 months, whichever comes first.
- f. Costs associated with the replacement of a transducer (e.g. Crane, docking or diver etc.).
- g. Sea trial, test and evaluation or other demonstrations.
- h. Products repaired or altered by anyone other than the FURUNO national distributor or an authorized dealer.
- i. Products on which the serial number is altered, defaced or removed.
- j. Problems resulting from an accident, negligence, misuse, improper installation, vandalism or water penetration.
- k. Damage resulting from a force majeure or other natural catastrophe or calamity.
- l. Damage from shipping or transit.
- m. Software updates, except when deemed necessary and warrantable by FURUNO.
- n. Overtime, extra labour outside of normal hours such as weekend/holiday, and travel costs above the 160 KM allowance
- o. Operator familiarization and orientation.

FURUNO Electric Company, March 1, 2011



## FURUNO Warranty for North America

FURUNO U.S.A., Limited Warranty provides a twenty-four (24) months LABOR and twenty-four (24) months PARTS warranty on products from the date of installation or purchase by the original owner. Products or components that are represented as being waterproof are guaranteed to be waterproof only for, and within the limits, of the warranty period stated above. The warranty start date may not exceed eighteen (18) months from the original date of purchase by dealer from Furuno USA and applies to new equipment installed and operated in accordance with Furuno USA's published instructions.

Magnetrons and Microwave devices will be warranted for a period of 12 months from date of original equipment installation.

Furuno U.S.A., Inc. warrants each new product to be of sound material and workmanship and through its authorized dealer will exchange any parts proven to be defective in material or workmanship under normal use at no charge for a period of 24 months from the date of installation or purchase.

Furuno U.S.A., Inc., through an authorized Furuno dealer will provide labor at no cost to replace defective parts, exclusive of routine maintenance or normal adjustments, for a period of 24 months from installation date provided the work is done by Furuno U.S.A., Inc. or an AUTHORIZED Furuno dealer during normal shop hours and within a radius of 50 miles of the shop location.

A suitable proof of purchase showing date of purchase, or installation certification must be available to Furuno U.S.A., Inc., or its authorized dealer at the time of request for warranty service.

This warranty is valid for installation of products manufactured by Furuno Electric Co. (hereafter FURUNO). Any purchases from brick and mortar or web-based resellers that are imported into other countries by anyone other than a FURUNO certified dealer, agent or subsidiary may not comply with local standards. FURUNO strongly recommends against importing these products from international websites or other resellers, as the imported product may not work correctly and may interfere with other electronic devices. The imported product may also be in breach of the local laws and mandated technical requirements. Products imported into other countries, as described previously, shall not be eligible for local warranty service.

For products purchased outside of your country please contact the national distributor of Furuno products in the country where purchased.

### WARRANTY REGISTRATION AND INFORMATION

To register your product for warranty, as well as see the complete warranty guidelines and limitations, please visit [www.furunousa.com](http://www.furunousa.com) and click on "Support". In order to expedite repairs, warranty service on Furuno equipment is provided through its authorized dealer network. If this is not possible or practical, please contact Furuno U.S.A., Inc. to arrange warranty service.

FURUNO U.S.A., INC.  
**Attention: Service Coordinator**  
4400 N.W. Pacific Rim Boulevard  
Camas, WA 98607-9408  
Telephone: (360) 834-9300  
FAX: (360) 834-9400

Furuno U.S.A., Inc. is proud to supply you with the highest quality in Marine Electronics. We know you had several choices when making your selection of equipment, and from everyone at Furuno we thank you. Furuno takes great pride in customer service.





**FURUNO ELECTRIC CO., LTD.**

9-52 Ashihara-cho,  
Nishinomiya, 662-8580, JAPAN

• FURUNO Authorized Distributor/Dealer

All rights reserved. Printed in Japan

Pub. No. IME-23940-B

(MENA ) FCV-600/FCV-800

A : JAN. 2023

B : MAR. 04, 2024



0 0 0 2 0 0 0 1 3 1 1