

# FURUNO

## INSTALLATION MANUAL

COLOR GPS/PLOTTER/SOUNDER  
COLOR DGPS/PLOTTER/SOUNDER

GP-1650WF  
MODEL GP-1650WDF



**FURUNO ELECTRIC CO., LTD.**  
NISHINOMIYA, JAPAN



(Elemental Chlorine Free)

The paper used in this manual  
is elemental chlorine free.

© **FURUNO ELECTRIC CO., LTD.**

9-52 Ashihara-cho,  
Nishinomiya 662-8580, JAPAN

Telephone : 0798-65-2111

Fax : 0798-65-4200

FURUNO Authorized Distributor/Dealer

All rights reserved.

Printed in Japan

FIRST EDITION :AUG. 2002

A2 : SEP. 09, 2005

Pub. No. IME-44242-A2

( DAMI ) GP-1650WF/1650WDF



\* 0 0 0 8 0 9 3 6 3 0 0 \*



\* I M E 4 4 2 4 2 A 2 0 \*



# SAFETY INSTRUCTIONS

## Safety Instructions for the Installer



### WARNING



**Do not work inside the equipment unless totally familiar with electrical circuits.**

Hazardous voltage which can shock, burn or cause serious injury exists inside the equipment.



**Turn off the power at the mains switchboard before beginning the installation. Post a sign near the switch to indicate it should not be turned on while the equipment is being installed.**

Fire, electrical shock or serious injury can result if the power is left on or is applied while the equipment is being



### CAUTION



**Ground the equipment to prevent electrical shock and mutual interference.**

**Confirm that the power supply voltage is compatible with the voltage rating of the equipment.**

Connection to the wrong power supply can cause fire or equipment damage. The voltage rating appears on the label at the rear of the display unit.

**Use the correct fuse.**

Use of a wrong fuse can cause fire or equipment damage.

**Keep the following compass safe distance.**

	Standard	Steering
Display unit	0.8 m	0.5 m



### CAUTION

**When handling the transducer cable, keep in mind the following points.**

- **Keep the cable away from oil and fuel.**
- **Keep the cable away from the place where it may be damaged during the installation.**
- **Do not paint the cable.**

The sheath of the transducer cable is made of chlorophrene rubber (or vinyl chloride). Therefore, do not paint the sheath with organic liquid (such as toluene) since it may harm the sheath.

# TABLE OF CONTENTS

---

<b>SYSTEM CONFIGURATION</b> .....	<b>iii</b>
<b>EQUIPMENT LISTS</b> .....	<b>iv</b>
<b>1. INSTALLATION</b> .....	<b>1-1</b>
1.1 Installation of Display Unit.....	1-1
1.2 Installation of Antenna Unit (GP-1650WDF only) .....	1-3
1.3 Installation of Transducers .....	1-4
1.4 Installation of Sensors .....	1-19
<b>2. WIRING</b> .....	<b>2-1</b>
<b>3. INITIAL SETTINGS</b> .....	<b>3-1</b>
3.1 NMEA Setting .....	3-1
3.2 Output Data Sentences .....	3-3
3.3 Antenna Height.....	3-4
3.4 DGPS Setting .....	3-5
3.5 External Equipment Setup (Option) .....	3-7
<b>4. INCORPORATION OF DGPS BEACON RECEIVER KIT     (for GP-1650WF)</b> .....	<b>4-1</b>
<b>PACKING LISTS</b>	
<b>OUTLINE DRAWINGS</b>	
<b>INTERCONNECTION DIAGRAM</b>	

# SYSTEM CONFIGURATION

The GP-1650WF/1650WDF mainly consists of a display unit, a GPS antenna and a dual frequency transducer. A DGPS beacon receiver is provided inside the display unit for GP-1650WDF type. The chart card drive in the display unit loads electronic charts. External equipment which may be connected include water temperature and speed sensors, autopilot, and DGPS beacon receiver.

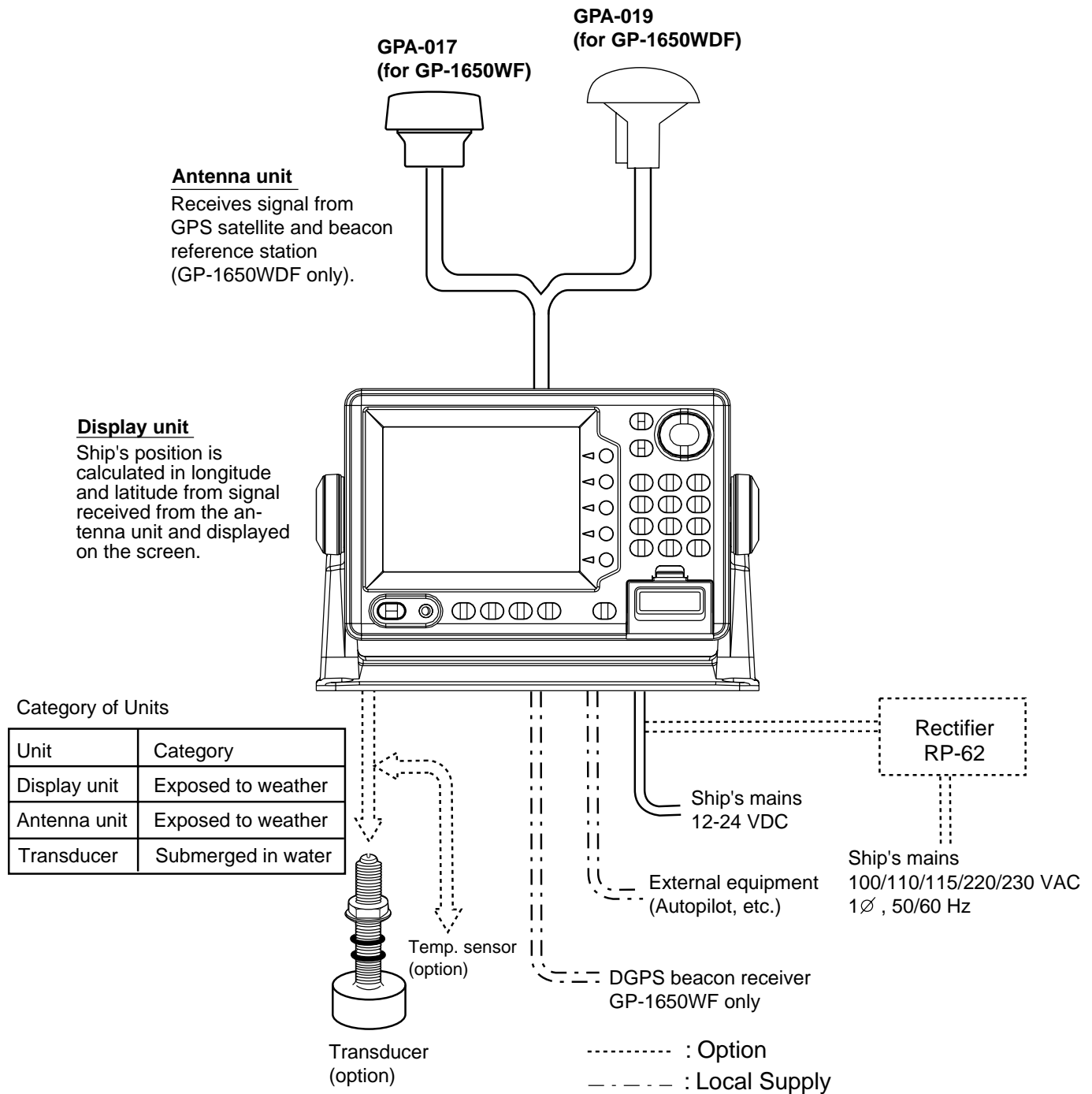

# EQUIPMENT LISTS

## Standard supply

Name	Type	Code No.	Qty	Remarks
Display Unit	GP-1650WF	-	1	
	GP-1650WDF	-		
Antenna Unit	GPA-017	-	1	for GP-1650WF
	GPA-019	-		for GP-1650WDF
Spare Parts*	SP14-02401	004-374-630	1	
Installation Materials*	CP14-05100	000-041-480	1	
Accessories*	FP14-02301	004-375-830	1	Hard cover
	FP14-02302	004-375-850	1	screws for hanger, screws for flush mount

\*: Refer to Packing list at the end of this manual.

## Optional equipment

Name	Type	Code No.	Remarks
DGPS Beacon Receiver Kit	GR-7000A-1650-10N-019	000-041-650	GPA-019, GR-7000A
	GR-7000A-1650-15N-019S	000-041-653	GPA-019S, GR-7000A TBC-PS-3D-15
Antenna cable Set	CP20-01700	004-372-110	30 m, for antenna cable extension
	CP20-01710	004-372-120	50 m, for antenna cable extension
Antenna cable assy.	TNC-PS-3D-15	000-133-670	15 m, for antenna cable extension
Cable Assy.	MJ-A7SPF0003-050	000-136-730-01	
Mast mount fixture	CP20-0111	004-365-780	
Right-angle antenna base	No.13-QA330	000-803-239	for antenna unit mounting
L-angle antenna base	No.13-QA310	000-803-240	
Antenna base for rail mounting	No.13-RC5160	000-806-114	
Antenna Unit	GPA-019S	-	for GP-1650WDF
	GPA-017S	-	for GP-1650WF

## Optional equipment (con't)

Name	Type	Code No.	Remarks
Transducer	520-5PSD	000-015-204	
	520-5PWD	000-015-126	With 8 m cable transom mount
	520-5MSD	000-015-212	With 8 m cable and water proof connector
ST sensor	ST-02MSB	000-137-986	Thru-hull type
	ST-02PSB	000-137-987	With 8 m cable, thru-hull type
Inner hull Kit S	22S0191	000-802-598	
Temperature sensor	T-02MTB	000-040-026	
	T-02MSB	000-040-040	
	T-03MSB	000-040-027	
Dual frequency Transducer	525ST-MSD	000-015-263	
	525ST-PWD	000-015-261	
Converter Connector	02S4147	000-141-082	
Rectifier	PR-62	000-013-484	for 100 VAC
		000-013-485	for 110 VAC
		000-013-486	for 220 VAC
		000-013-487	for 230 VAC
Cable Assy.	MJ-A6SPF0007-100	000-125-237	6P-6P, 10 m, for autopilot
	MJ-A6SPF0012-050	000-134-424	6P-6P, 5 m
	MJ-A6SPF0012-100	000-133-817	6P-6P, 10 m
	MJ-A6SPF0011-050	000-132-244	6P-4P, 5 m
	MJ-A6SPF0011-100	000-132-336	6P-4P, 10 m
RAM Card	00RAM02MC-004	004-371-790	2MB
C-MAP modification kit	1650/1850-MAP	004-376-420	

## EQUIPMENT LISTS

This page is intentionally left blank.



# 1. INSTALLATION

---

## 1.1 Installation of Display Unit

### Mounting considerations

The display unit can be installed on a tabletop, on the overhead or flush mounted in a console or panel.

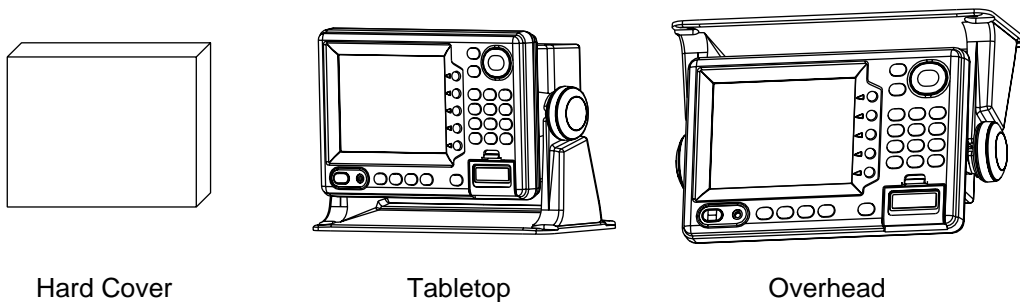

*Tabletop, overhead mounting methods*

When selecting a mounting location for the display unit keep the following in mind:

- Keep the display unit out of direct sunlight.
- The temperature and humidity should be moderate and stable.
- Locate the unit away from exhaust pipes and vents.
- The mounting location should be well ventilated.
- Mount the unit where shock and vibration are minimal.
- Keep the unit away electromagnetic field generating equipment such as motor, generator.
- For maintenance and checking purposes, leave sufficient space at the sides and rear of the unit and leave slack in cables.
- A magnetic compass will be affected if placed too close to the display unit. Observe the following compass safe distances to prevent disturbance to the magnetic compass:

Standard compass: 0.8 meters

Steering compass: 0.5 meters

### Mounting procedure

Follow the procedure below to mount the display unit on a tabletop or the overhead.

#### **Tabletop, overhead mounting**

1. Fix the hanger by four pan head screws 5 X 16.
2. Screw knob bolts in display unit, set it to hanger, and tighten knob bolts.
3. Attach hard cover to protect LCD.

## 1. INSTALLATION

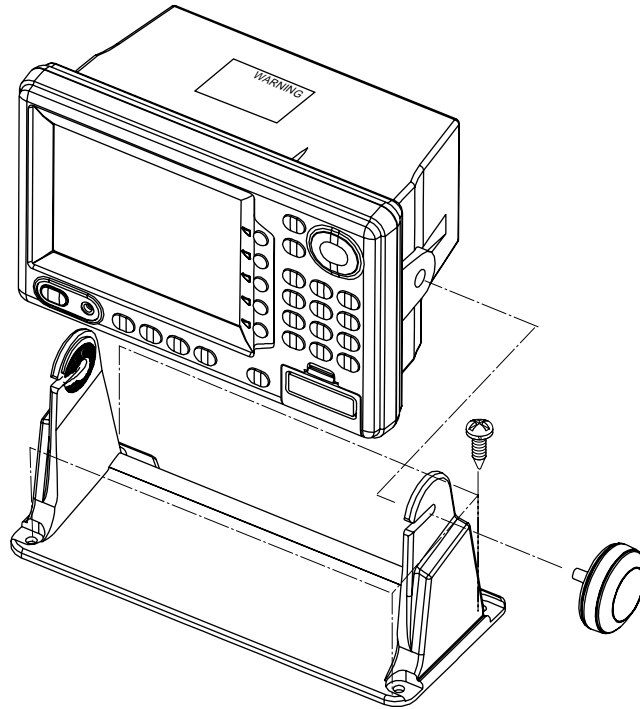

*Tabletop, overhead mounting of display unit*

### **Flush mounting**

Note: Use supplied pan head screws when the thickness of the bulkhead is from 11 to 14 mm. For bulkhead which exceeds 14 mm in thickness the length of the pan head screws should be bulkhead thickness+7.8±1.5 mm. Also the length of B should max. 8mm.

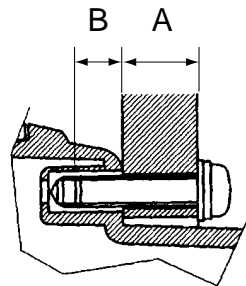

1. Prepare a cutout in the mounting location whose dimensions are as shown in on the next page.
2. Fix the display unit by six pan head screws M4 X 20. Refer to the outline drawing on page D-2.

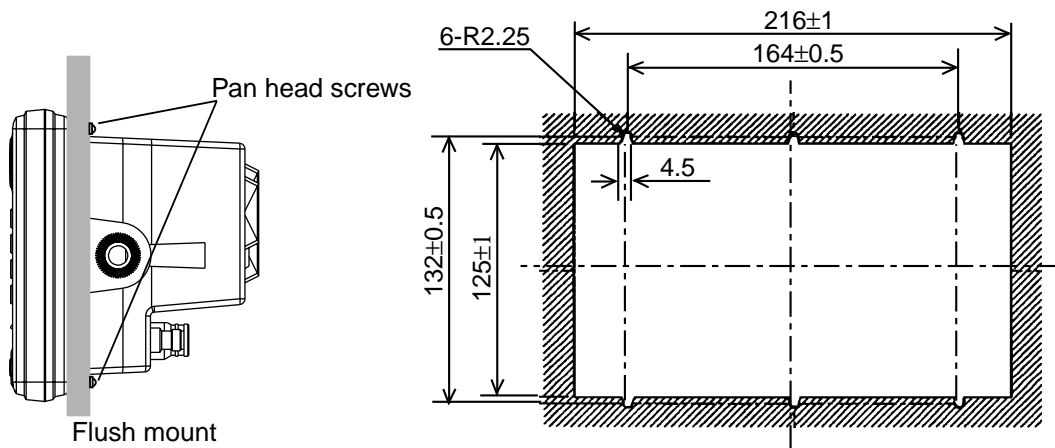

*Flush mounting of display unit*

## 1.2 Installation of Antenna Unit (GP-1650WDF only)

### Mounting considerations

Install the antenna unit referring to the installation diagram on page D-3 or D-4. When selecting a mounting location for the antenna unit, keep in mind the following points:

- Select a location out of the radar beam. The radar beam will obstruct or prevent reception of the GPS satellite signal.
- The location should be well away from a VHF antenna. A GPS receiver is interfered by a harmonic wave of a VHF antenna.
- There should be no interfering object within the line-of-sight to the satellites. Objects within line-of-sight to a satellite, for example, a mast, may block reception or prolong acquisition time.
- Mount the antenna unit as high as possible. Mounting the antenna unit as high as possible keeps it free of interfering objects and water spray, which can interrupt reception of GPS satellite signal if the water freezes.
- Do not shorten the antenna cable.
- If the antenna cable is to be passed through a hole which is not large enough to pass the connector, you may unfasten the connector with a needle nose pliers and 3/8-inch open-end wrench. Refasten it as shown in the figure below after running the cable through the hole.

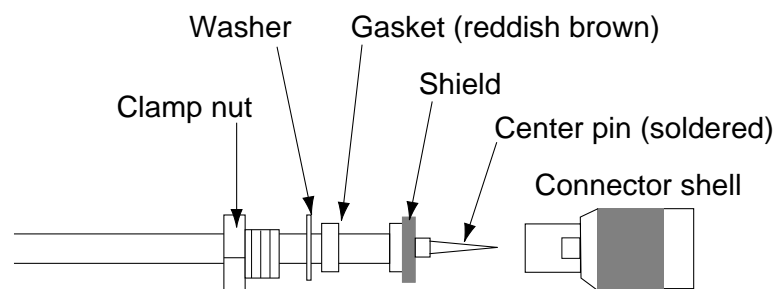

*How to assemble the connector*

## 1.3 Installation of Transducers

### Installing the inside-hull mount transducer

#### Necessary tools

You will need the following tools:

- Sandpaper (#100)
- Silicone sealant
- Silicone grease

#### Remarks on installation

- Do the installation with the boat hauled out of the water.
- Turn off the engine while installing the equipment.
- Install the transducer in the engine room.

#### Selecting the mounting location

Keep the following points in mind when selecting a mounting location:

- The mounting location should be where the hull is of single-hull thickness and is void of air or flotation materials other than solid fiberglass between the transducer face and the water.
- Do not place the transducer over hull struts or ribs which run under the hull.
- Avoid a location where the rising angle of the hull exceeds 15°, to minimize the effect of the boat's rolling.
- You will finalize the mounting location through some trial and error. The procedure for this is shown later.

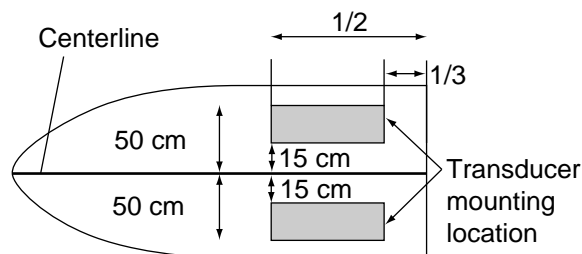

*Inside-hull transducer mounting location*

**Attaching the transducer**

1. Clean the transducer face to remove any foreign material. Lightly roughen the transducer face with #100 sandpaper. Also, roughen the inside of the hull where the transducer is to be mounted.
2. Warm the silicone sealant to 40°C before usage to soften it. Coat the transducer face and mounting location with silicone sealant.

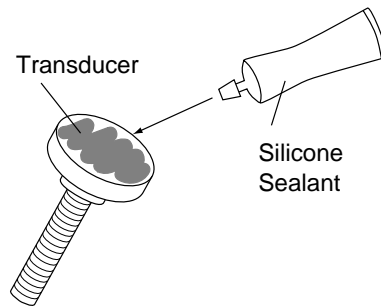

*Coating the transducer face with silicone sealant*

3. Press the transducer firmly down on the hull and gently twist it back and forth to remove any air which may be trapped in the silicone sealant.

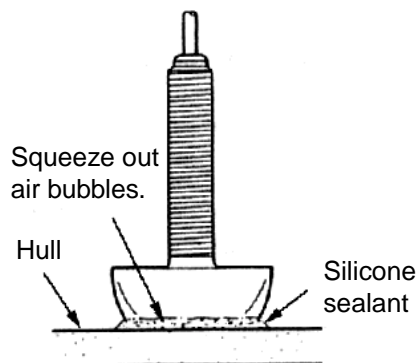

*Attaching transducer to hull with silicone sealant*

## 1. INSTALLATION

### Observing the picture

1. Press the [POWER] key to turn on the display unit.
2. Press the [SNDR] key to select the sounder display.
3. Press the MODE/FREQ soft key to display the following window.

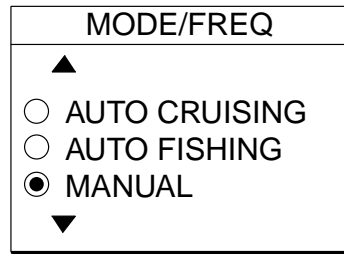

*Mode FREQ selection window*

4. Select MANUAL with the cursor pad.
5. Press the RETURN soft key.
6. Press the GAIN soft key to display the gain window.

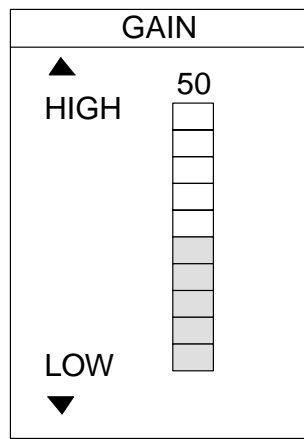

*Gain window*

7. Confirm that the gain is set at 50 (midpoint).
8. Press the RETURN soft key.
9. Press the RANGE soft key.
10. Press ▲ to select "15 ft".
11. Note the depth seabed.

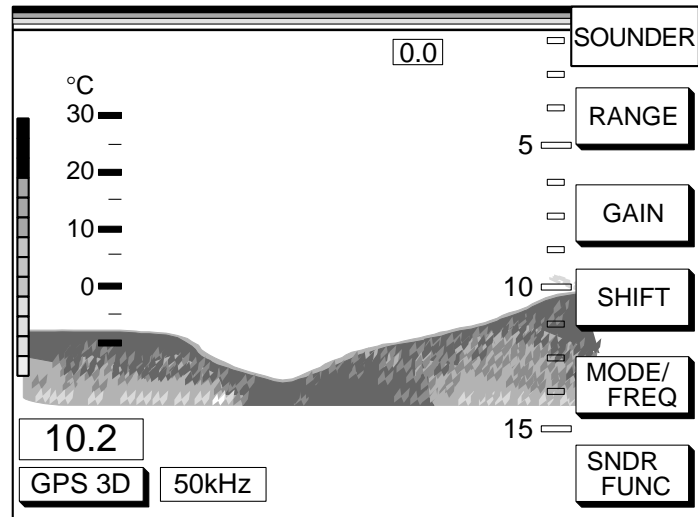

*Video sonder picture*

If the bottom is displayed in reddish brown and the depth indication appears the mounting location is suitable. You can leave the transducer in position.

If the bottom is not displayed in reddish brown, the mounting location is unsuitable. Relocate the transducer and do the following.

1. Press the [POWER] key to turn off the power.
2. Gently dismount the transducer with piece of wood.
3. Do steps 1 through 5 in the previous procedure. Repeat until a suitable location is found.

### **Final preparation**

Support the transducer with a piece of wood to keep it in place while it is drying. Let the transducer dry 24 – 72 hours.

## Installing the thru-hull mount transducer

### Transducer mounting location

This type of mounting provides the best performance of all, since the transducer protrudes from the hull and the effect of air bubbles and turbulence near the hull skin is reduced. When the boat has a keel, the transducer should be at least 30 cm away from it. Typical through hull mountings are shown in the figure on the next page.

The performance of the video sounder is directly related to the mounting location of the transducer, especially for high-speed cruising. The installation should be planned in advance, keeping the standard cable length (8 m) and the following factors in mind.

- Air bubbles and turbulence caused by movement of the boat seriously degrade the sounding capability of the transducer. The transducer should, therefore, be located in a position where water flow is the smoothest. Noise from the propellers also adversely affects performance and the transducer should not be mounted nearby. The lifting strakes are notorious for creating acoustic noise, and these must be avoided by keeping the transducer inboard of them.
- The transducer must always remain submerged, even when the boat is rolling, pitching or up on a plane at high speed.
- A practical choice would be somewhere between 1/3 and 1/2 of the boat's length from the stern. For planing hulls, a practical location is generally rather far astern, so that the transducer is always in water regardless of the planing attitude.

### Transducer outline drawings

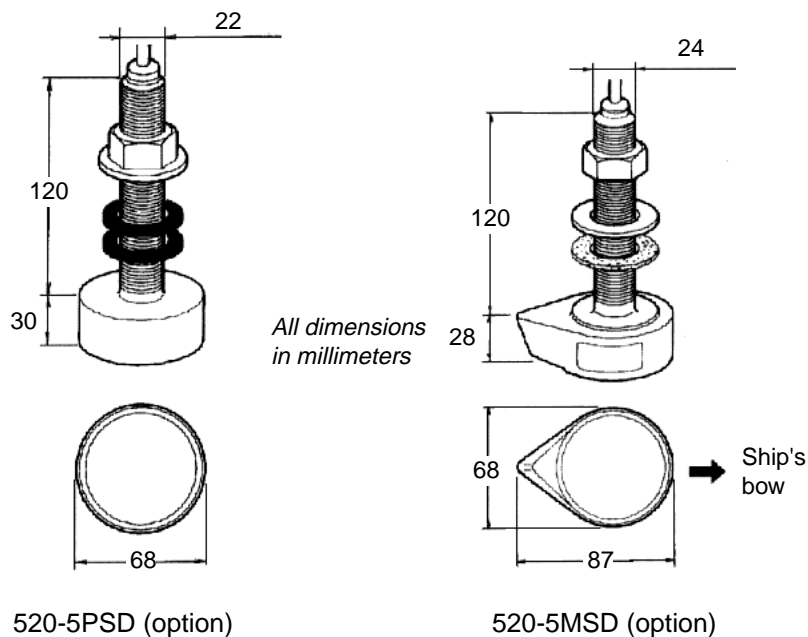

*Transducer outline drawings*



**Acceptable transducer mounting location**

**Deep-V hull**

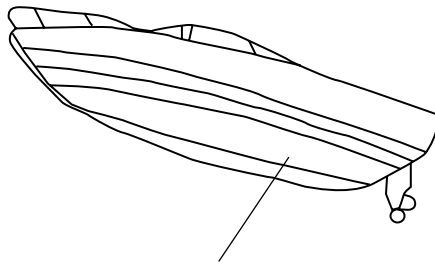

- Position 1/2 to 1/3 length of the hull from stern.
- 15 to 30 cm off center line (inside first lifting strakes.)

*Transducer mounting location on deep-V hull*

**High speed V-planning hull**

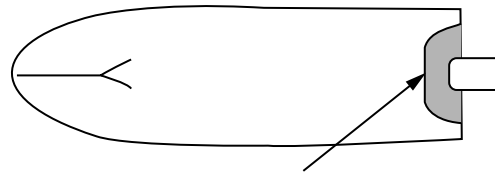
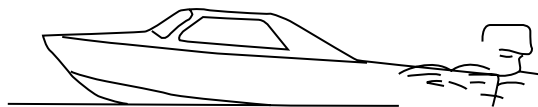

- Within the wetted bottom area
- Deadrise angle within 15°

*Transducer mounting location on high speed V-planning hull*

**Typical through-hull mount transducer installations**

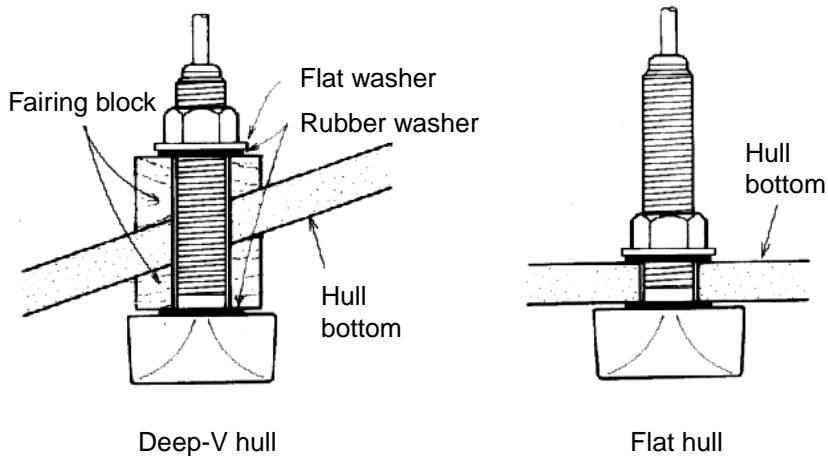

*Typical through-hull mount transducer installations*

## 1. INSTALLATION

### **Procedure for installing the thru-hull mount transducer**

1. With the boat hauled out of the water, mark the location selected for mounting the transducer on the bottom of the hull.
2. If the hull is not level within 15° in any direction, fairing blocks made out of teak should be used between the transducer and hull, both inside and outside, to keep the transducer face parallel with the water line. Fabricate the fairing block as shown below and make the entire surface as smooth as possible to provide an undisturbed flow of water around the transducer. The fairing block should be smaller than the transducer itself to provide a channel to divert turbulent water around the sides of the transducer rather than over its face.

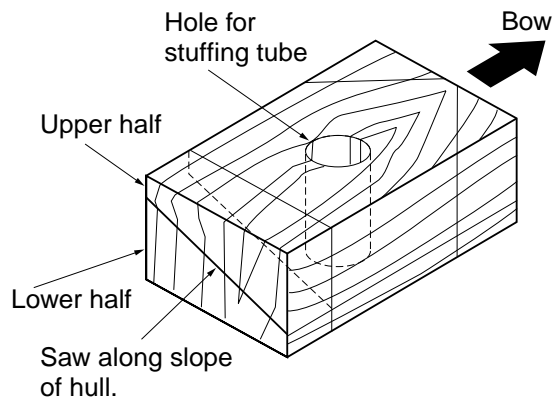

*Construction of fairing block*

3. Drill a hole just large enough to pass the threaded stuffing tube of the transducer through the hull, making sure it is drilled vertically.
4. Apply a sufficient amount of high quality caulking compound to the top surface of the transducer, around the threads of the stuffing tube and inside the mounting hole (and fairing blocks if used) to ensure watertight mounting.
5. Mount the transducer and fairing blocks and tighten the locking nuts. Be sure that the transducer is properly oriented and its working face is parallel to the waterline.

**Note:** Do not over-stress the stuffing tube and locking nuts through excessive tightening, since the woodblock will swell when the boat is placed in the water. It is suggested that the nut be tightened lightly at installation and retightened several days after the boat has been launched.

## Installing the transom mount transducer

This type of mounting is very commonly employed, usually on reactively small I/O or outboard boats. Do not use this method on an inboard motor boat because turbulence is created by the propeller ahead of the transducer.

There are two methods of installation: flush with hull (for flat hulls) and projecting from hull (for deep V-hulls).

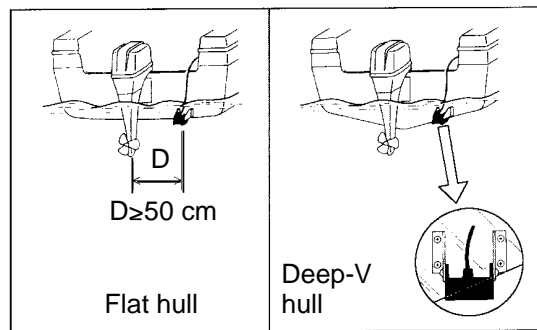

*Transom mount transducer mounting locations*

### Installing the transom mount transducer flush with hull (for flat hulls)

A suitable mounting location is at least 50 cm away from the engine and where the water flow is smooth.

1. Drill four pilot holes in the mounting location.
2. Attach the transducer to the bracket with tapping screws (supplied).
3. Adjust the transducer position so the transducer faces right to the bottom.

**Note:** If necessary, to improve water flow and minimize air bubbles staying on the transducer face, incline the transducer about 5° at the rear. This may require a certain amount of experimentation for fine tuning at high cruising speeds.

4. Fill the gap between the wedge front of the transducer and transom with epoxy material to eliminate any air spaces.

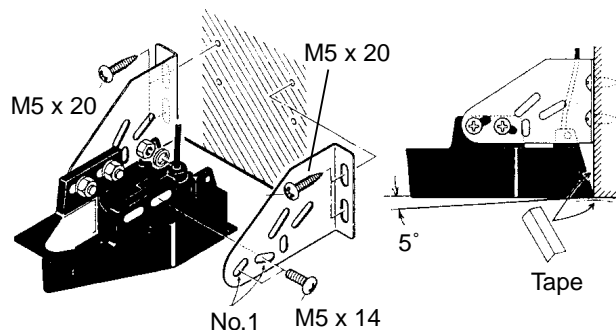

*Transom mount transducer, mounting flush with hull*

## 1. INSTALLATION

### **Installing the transom mount transducer projecting from hull (for deep-V hulls)**

This method is employed on deep-V hulls and provides good performance because the effects of air bubbles are minimal. Install the transducer parallel with water surface; not flush with hull. If the boat is placed on a trailer care must be taken not to damage the transducer when the boat is hauled out of the water and put on the trailer.

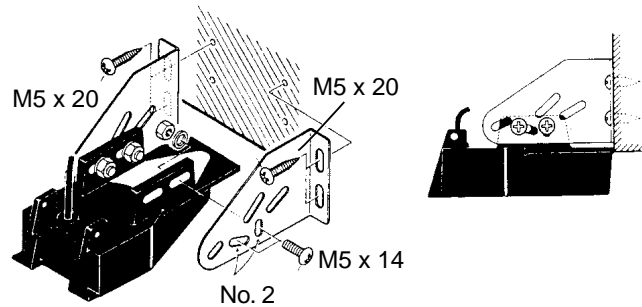

*Transom mount transducer, projecting from hull*

### **Transducer preparation**

Before putting the boat in water, wipe the face of the transducer thoroughly with a detergent liquid soap. This will lessen the time necessary for the transducer to have good contact with the water. Otherwise the time required for complete "saturation" will be lengthened and performance will be reduced.

Do not paint the transducer. Performance will be affected.

### **Triducer**

#### **525ST-MSD**

The triducer is designed for thru-hull mounting.

#### **Mounting considerations**

When selecting a mounting location keep the following points in mind:

- Air bubbles and turbulence caused by movement of the boat seriously degrade the sounding capability of the transducer. The transducer should, therefore, be located in a position where water flow is the smoothest. Noise from the propellers also adversely affects performance and the transducer should not be mounted nearby. The lifting strakes are notorious for creating acoustic noise, and these must be avoided by keeping the transducer inboard of them.
- The transducer must always remain submerged, even when the boat is rolling, pitching or up on a plane at high speed.
- A practical choice would be somewhere between 1/3 and 1/2 of the boat's length from the stern. For planning hulls, a practical location is generally rather far astern, so that the transducer is always in water regardless of the planning attitude.

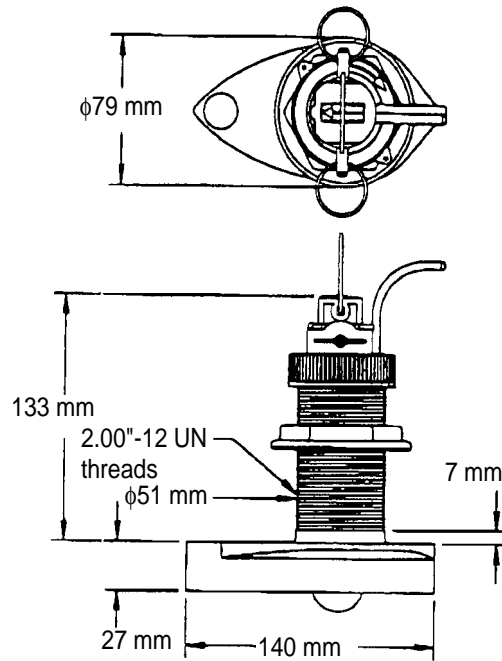

*Dimensions of triducer 525ST-MSD*

### **525ST-PWD**

The Transom Mount Transducer or TRIDUCER<sup>®</sup> Multisensor with Integral Release Bracket 525ST-PWD is manufactured by AIRMAR Co. These instructions are included with the sensor.

### **Pre-test for speed and temperature**

Connect the sensor to the instrument and spin the paddlewheel. Check for a speed reading and the approximate air temperature. If there is no reading, return the sensor to your place of purchase.

### **Tools and materials needed**

Scissors

Masking tape

Safety goggles

Dust mask

Electric drill

Drill bit for:

Bracket holes: 4mm, #23, or 9/64"

Fiberglass hull: chamfer bit (preferred),  
6mm, or 1/4"

Transom hole: 19mm or 3/4" (optional)

Cable clamp holes: 3mm or 1/8"

Screwdrivers

Straight edge

## 1. INSTALLATION

Marine sealant

Pencil

Zip-ties

Water-based antifouling paint (**mandatory in salt water**).

### **Mounting location**

To ensure the best performance, the sensor must be submerged in aeration-free and turbulence-free water. Mount the sensor close to the centerline of the boat. On slower heavier displacement hulls, positioning it farther from the centerline is acceptable.

Allow adequate space above the bracket for it to release and rotate the sensor upward.

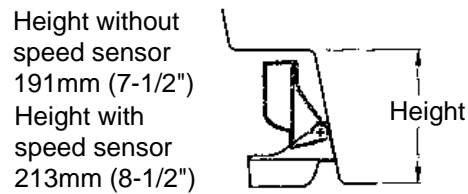

*Height required at mounting location*

**Note 1:** Do not mount the sensor in an area of turbulence or bubbles: near water intake or discharge openings; behind strakes, struts, fittings, or hull irregularities; behind eroding paint (an indication of turbulence).

**Note 2:** Avoid mounting the sensor where the boat may be supported during trailering, launching, hauling, and storage.

**Note 3:** For **single drive boat**, mount on the starboard side at least 75 mm (3") beyond the swing radius of the propeller.

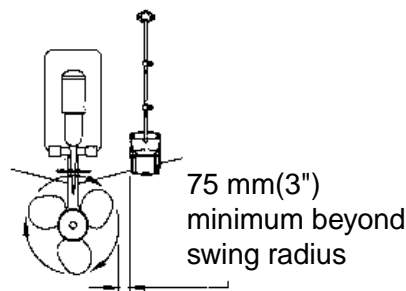

*Mounting location on single drive boat*

**Note 4:** For **twin drive boat**, mount between the drives.

**Installation of bracket**

1. Cut out the installation template shown on the left.
2. At the selected location, position the template, so the arrow at the bottom is aligned with the bottom edge of the transom. Being sure the template is parallel to the waterline, tape it in place.

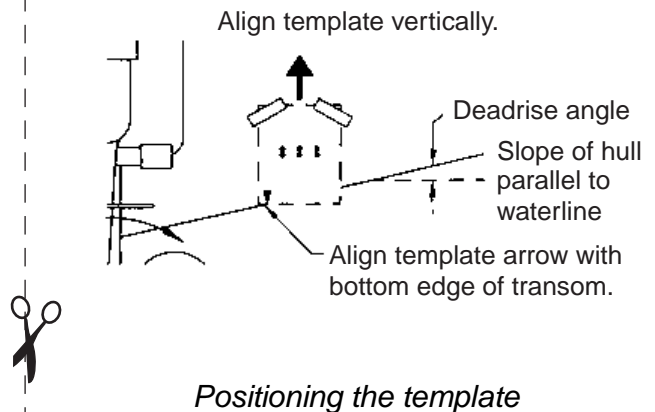
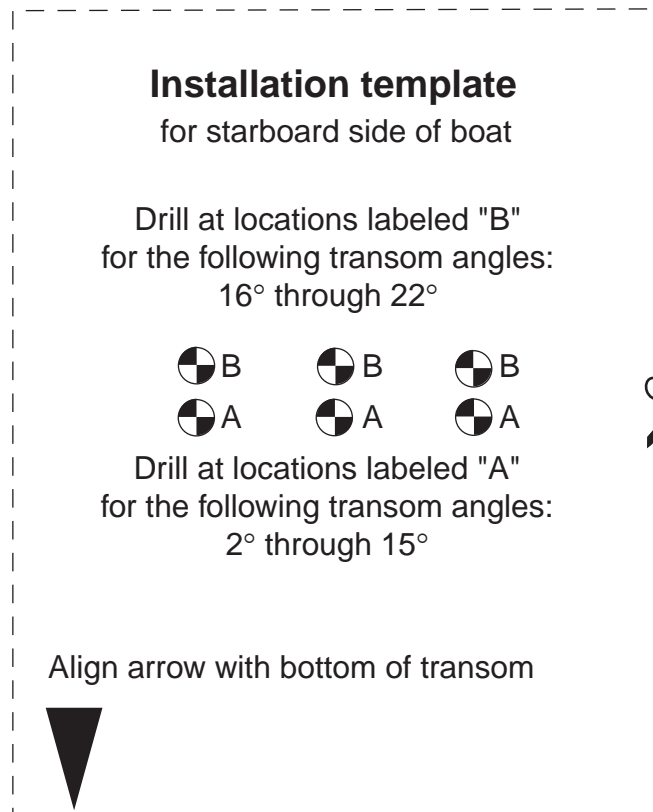

**Warning:** Always wear safety goggles and a dust mask.

3. Using a 4 mm, #23, or 9/64" bit, drill three holes 22 mm (7/8") deep at the locations indicated. To prevent drilling too deeply, wrap masking tape around the bit 22 mm (7/8") from the point.

**Fiberglass hull:** Minimize surface cracking by chamfering the gelcoat. If a chamfer bit or countersink bit is not available, start drilling with a 6mm or 1/4" bit to a depth of 1 mm (1/16").

4. If you know your transom angle, the bracket is designed for a standard 13° transom angle.

11°-18° angle: No shim is required. Skip to step 3 in "Adjusting".

Other angles: The shim is required. Skip to step 2 of "Adjusting".

If you do not know the transom angle, temporarily attach the bracket and sensor to the transom to determine if the plastic shim is needed.

## 1. INSTALLATION

- Using the two #10 x 1-1/4" self-tapping screws, temporarily screw the bracket to the hull. DO NOT tighten the screws completely at this time. Follow the step 1-4 in "Attaching the Sensor to the Bracket", before proceeding with "Adjusting".

### Adjusting

- Using a straight edge, sight the underside of the sensor relative to the underside of the hull. The stern of the sensor should be 1-3 mm (1/16-1/8") below the bow of the sensor or parallel to the bottom of the hull.

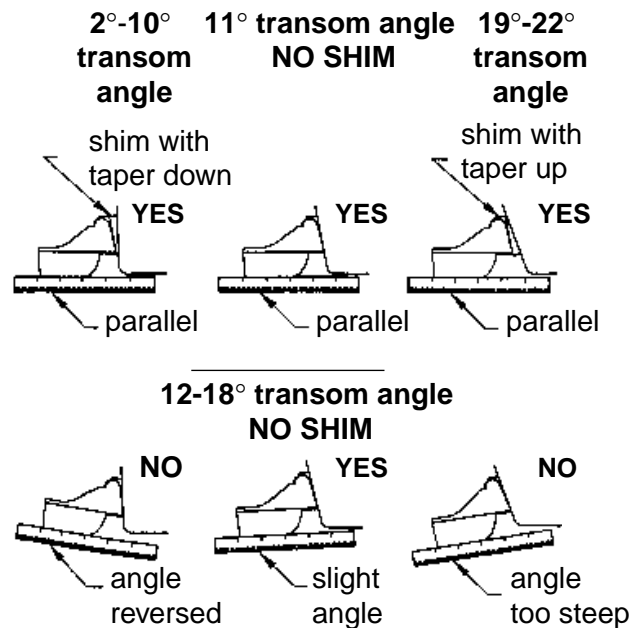

*Sensor position and transom angle*

Note: Do not position the bow of the sensor lower than the stern because aeration will occur.

- To adjust the sensor's angle relative to the hull, use the tapered plastic shim provided. If the bracket has been temporarily fastened to the transom, remove it, Key the shim in place on the back of the bracket.

**2°-10° transom angle (stepped transom and jet boats):** Position the shim with the tapered end down.

**19°-22° transom angle (small aluminum and fiberglass boats):** Position the shim with the tapered end up.

- If the bracket has been temporarily fastened to the transom, remove it. Apply a marine sealant to the threads of the two #10 x 1-1/4" self tapping screws to prevent water seeping into the transom. Screw the bracket to the hull. Do not tighten the screws completely at this time.
- Repeat step 1 to ensure that the angle of the sensor is correct.

Note: Do not position the sensor farther into the water than necessary to avoid increasing drag, spray, and water noise and reducing boat speed.

- Using the vertical adjustment space on the bracket slots, slide the sensor up or down to provide a projection of 3 mm (1/8"). Tighten the screws.



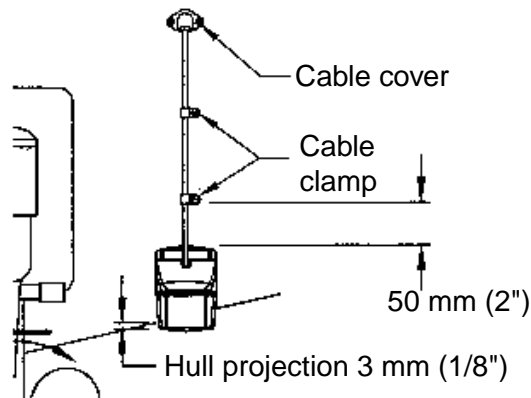

*Vertical adjustment and cable routing*

### **Attaching the sensor to the bracket**

1. If the retaining cover near the top of the bracket is closed, open it by depressing the latch and rotating the cover downward.

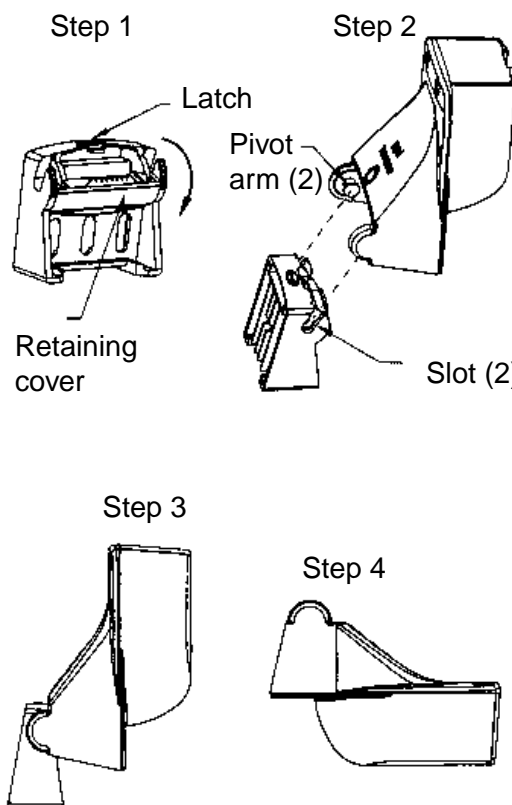

*Attaching the sensor to the bracket*

2. Insert the sensor's pivot arms into the slots near the top of the bracket.
3. Maintain pressure until the pivot arms click into place.
4. Rotate the sensor downward until the bottom snaps into the bracket.
5. Close the retaining cover to prevent the accidental release of the sensor when the boat is underway.

## 1. INSTALLATION

### **Cable routing**

Route the sensor cable over the transom, through a drain hole, or through a new hole drilled in the transom above the waterline.

Never cut the cable or remove the connector; this will void the warranty.

Always wear safety goggles and a dust mask.

1. If a hole must be drilled, choose a location well above the waterline. Check for obstructions such as trim tabs, pumps, or wiring inside the hull. Mark the location with a pencil. Drill a hole through the transom using a 19 mm or 3/4" bit (to accommodate the connector).
2. Route the cable over or through the transom.
3. On the outside of the hull secure the cable against the transom using the cable clamps. Position a cable clamp 50 mm(2") above the bracket and mark the mounting hole with a pencil.
4. Position the second cable clamp halfway between the first clamp and the cable hole. Mark this mounting hole.
5. If a hole has been drilled in the transom, open the appropriate slot in the transom cable cover. Position the cover over the cable where it enters the hull. Mark the two mounting holes.
6. At each of the marked locations, use a 3 mm or 1/8" bit to drill a hole 10 mm (3/8") deep. To prevent drilling too deeply, wrap masking tape around the bit 10 mm (3/8") from the point.
7. Apply marine sealant to the threads of the #6 x 1/2" self-tapping screw to prevent water from seeping into the transom. If you have drilled a hole through the transom, apply marine sealant to the space around the cable where it passes through the transom.
8. Position the two cable clamps and fasten them in place. If used, push the cable cover over the cable and screw it in place.
9. Route the cable to the instrument being careful not to tear the cable jacket when passing it through the bulkhead(s) and other parts of the boat. To reduce electrical interference, separate the sensor cable from other electrical wiring and "noise" sources. Coil any excess cable and secure it in place with zip-ties to prevent damage.

## 1.4 Installation of Sensors

### Transom mount water temperature sensor T-02MTB

- Fix the cable at a convenient location with cable clamp.
- When the cable is led in through the transom board, make a hole of approx. 17 mm diameter to pass the connector. After passing the cable, fill the hole with a sealing compound.

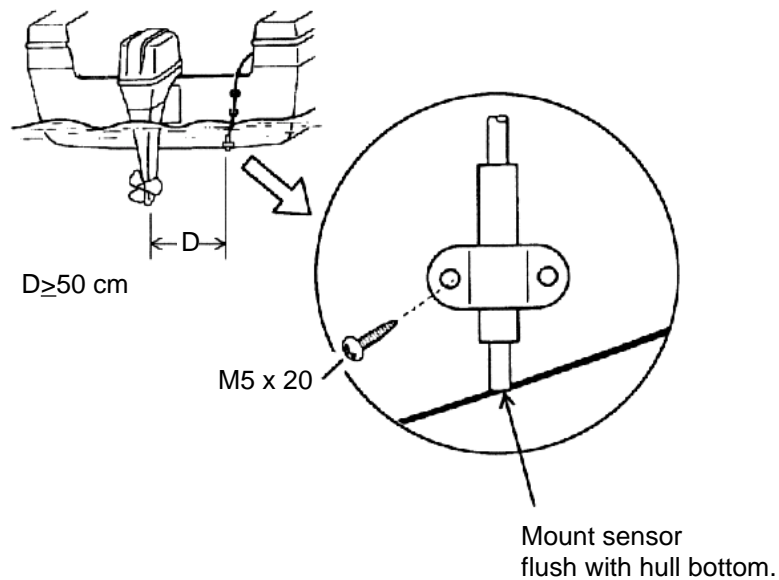

*How to install transom mount water temperature sensor T-02MTB*

## 1. INSTALLATION

### Thru-hull mount water temperature sensor T-02MSB, T-03MSB

Select a suitable mounting location considering the following points:

- Select a mid-boat flat position. The sensor does not have to be installed perfectly perpendicular. The sensor must not be damaged in dry-docking operation.
- Select a place apart from equipment generating heat.
- Select a place in the forward direction viewing from the drain hole, to allow for circulation of cooling water.
- Select a place free from vibration.

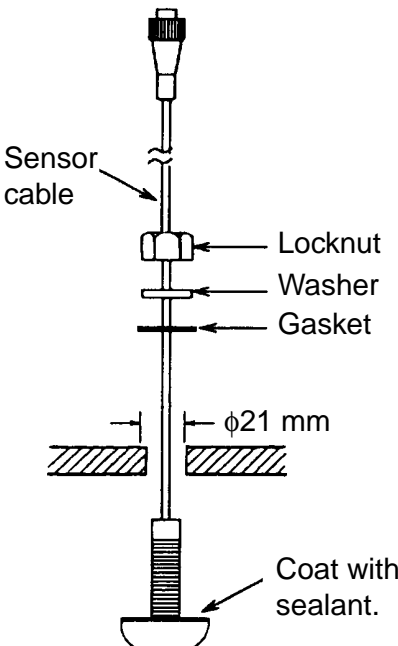
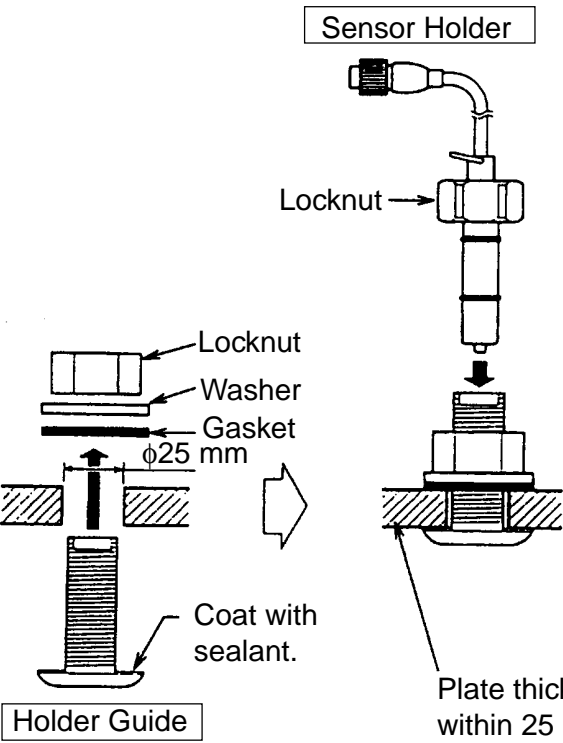
T-02MSB	T-03MSB
 <p><b>Mounting procedure</b></p> <ol style="list-style-type: none"> <li>1. Drill a hole of 21 mm in diameter in the mounting location.</li> <li>2. Pass the sensor cable through the hole.</li> <li>3. Pass gasket, washer and locknut onto cable in that order.</li> <li>4. Coat the sensor flange with high quality sealant and then fasten the sensor with the locknut. (Torque: max. 59N·m)</li> <li>5. Launch the boat to check for water leakage around the sensor.</li> </ol>	 <p><b>Mounting procedure</b></p> <ol style="list-style-type: none"> <li>1. Drill a hole of 25 mm in diameter in the mounting location.</li> <li>2. Coat holder guide with high quality sealant, and pass gasket, washer and locknut onto holder guide in that order and then tighten the locknut.</li> <li>3. Set the sensor holder to the holder guide from inside the boat and then tighten the locknut.</li> <li>4. Launch the boat to check for water leakage around the sensor.</li> </ol>

*Thru-hull mount water temperature sensors T-02MSB, T-03MSB*

## Thru-hull mount water temperature/speed sensors ST-02MSB, ST-02PSB

Select a suitable mounting location considering the following:

- Select a mid-boat flat position. The sensor does not have to be installed perfectly perpendicular. The sensor must not be damaged in dry-docking operation.
- Select a place apart from equipment generating heat.
- Select a place in the forward direction viewing from the drain hole, to allow for circulation of cooling water.
- Select a place free from vibration.

1. Dry-dock the boat.
2. Make a hole of approx. 51 mm diameter.
3. Unfasten locknut and remove the sensor section.
4. Apply high-grade sealant to the flange of the sensor.
5. Pass the sensor casing through the hole.
6. Face the notch on the sensor toward boat's bow and tighten the flange.
7. Set the sensor section to the sensor casing and tighten the locknut.
8. Launch the boat and check for water leakage around the sensor.

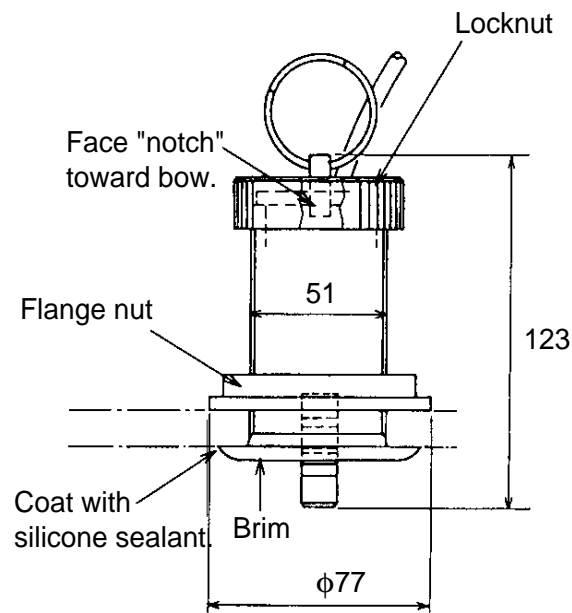

*Water temperature/speed sensor ST-02MSB, ST-02PSB*

## 1. INSTALLATION

This page is intentionally left blank.

## 2. WIRING

All wiring are terminated at the rear of the display unit.

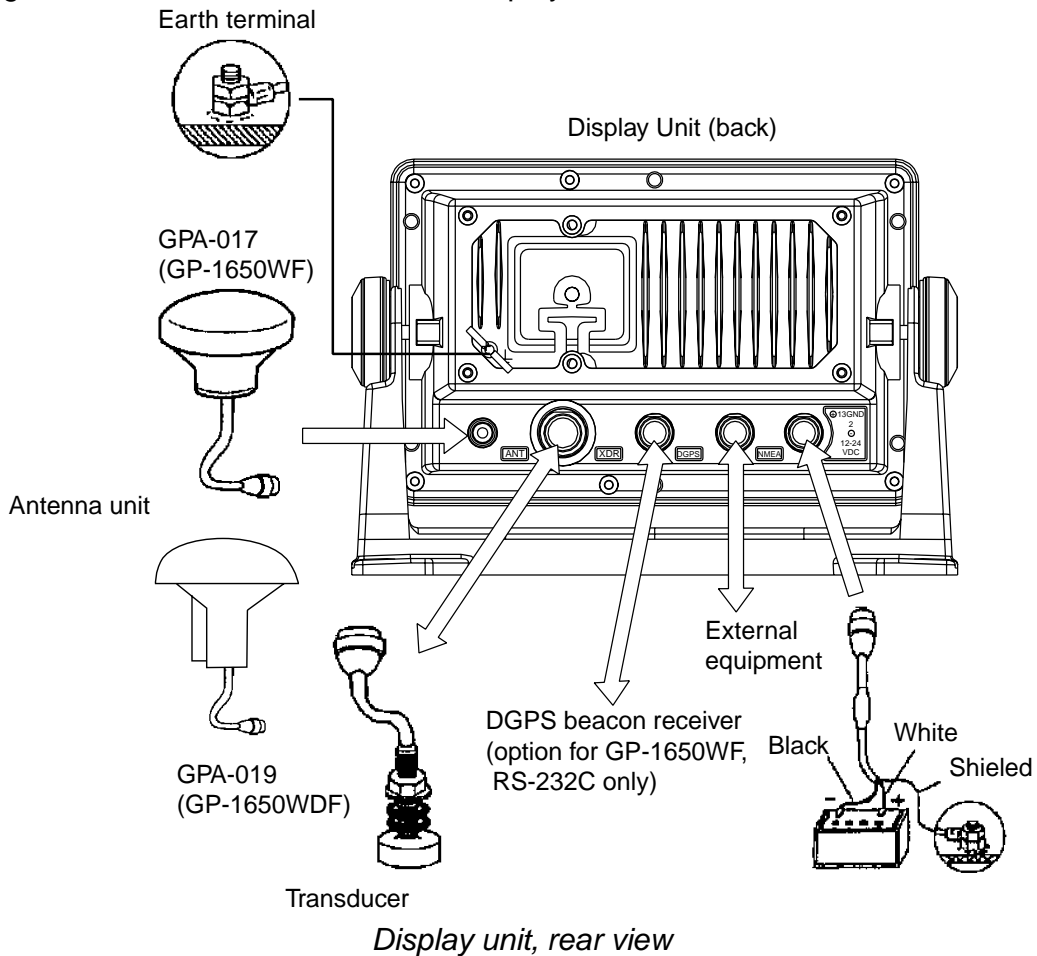

### Power cable

Connect the power cable to the power connector. Connect the leads to the battery (12 or 24 VDC); white to plus(+) terminal and black to minus(-) terminal.

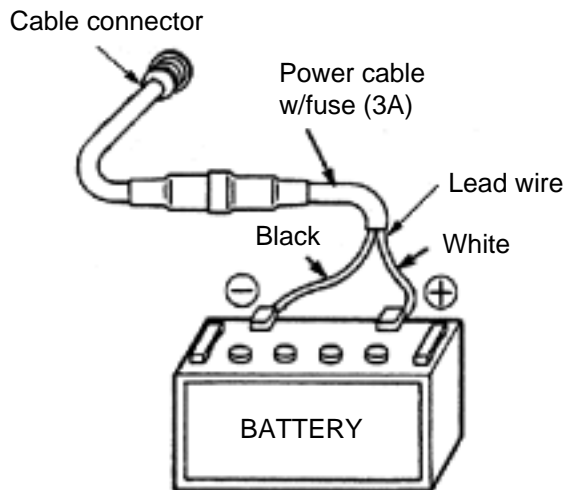

*Connecting the power cable to the battery*

## Antenna unit

Connect the antenna unit cable to the ANT connector.

## Transducer

Connect the transducer cable to the XDR connector. Connect the water temperature sensor (option) or water temperature/speed sensor (option) to the XDR connector with the converter connector (Type : 02S4147, Code No. : 000-141-082, option).

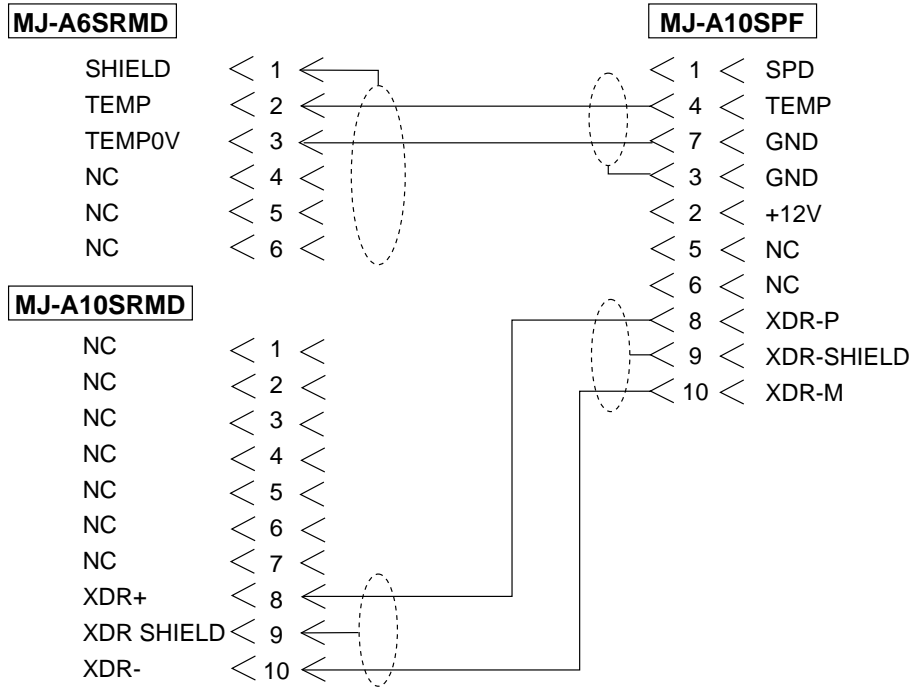

*Wiring of converter connector for water temperature sensor*

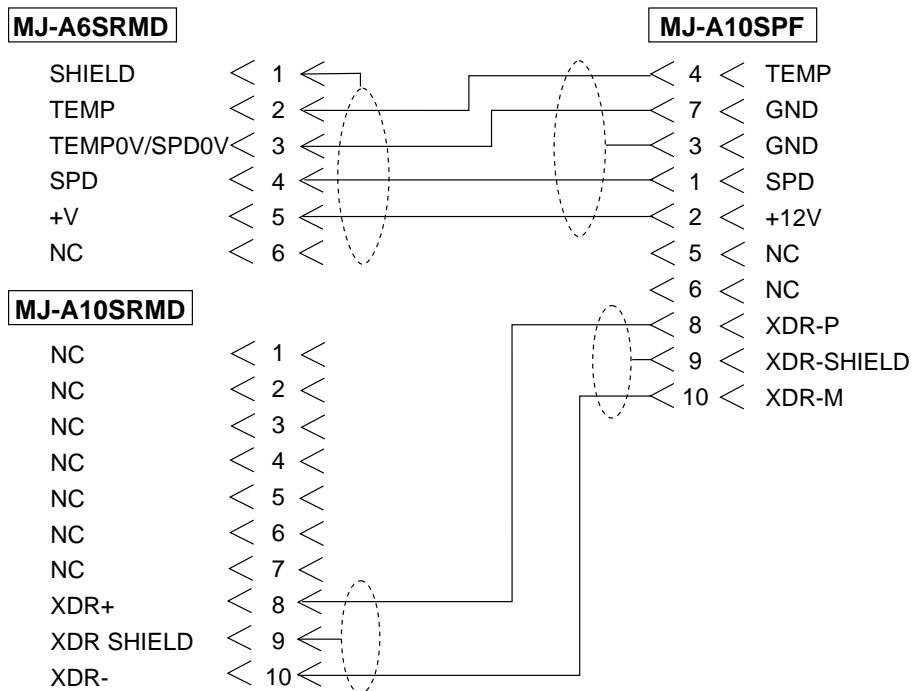

*Wiring of converter connector for water temperature/speed sensor*



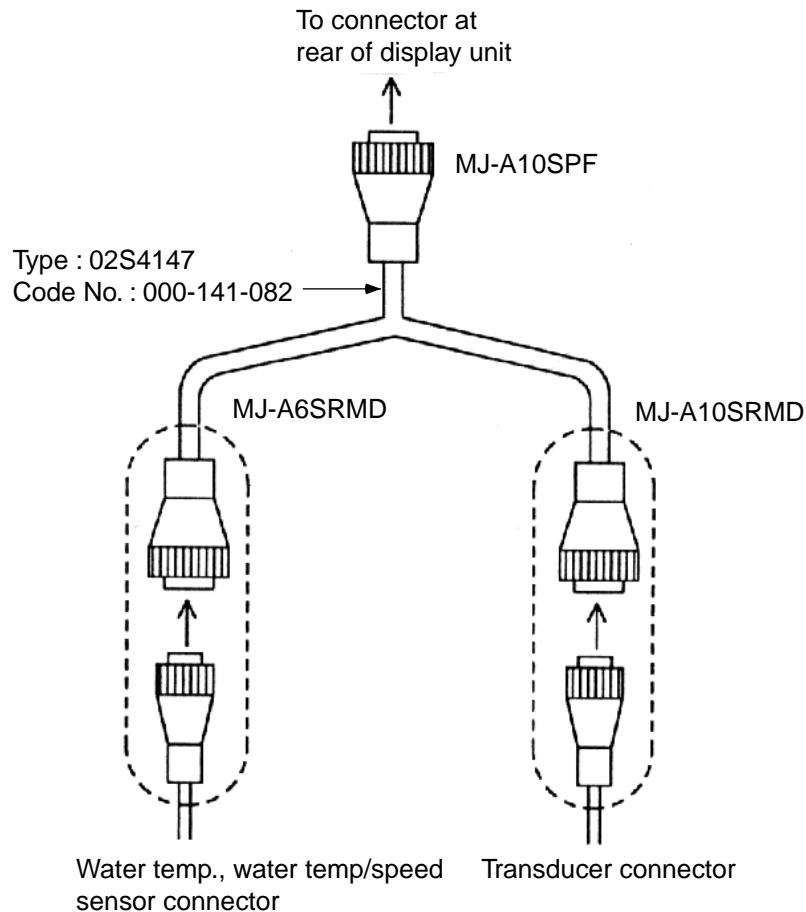

*Connection of transducer, water temperature sensor, water temperature/speed sensor*

## Ground

The display unit contains several CPUs. While they are operating, they radiate noise, which can interfere with radio equipment. Ground the unit to prevent interference. The grounding wire should be 1.25 sq or larger and as short as possible. Connect the grounding wire to ship's ground. On a fiberglass boat, it is best to install a ground plate that measures about 20 cm by 30 cm on the outside of the hull bottom to provide a ground point. If this is not practical, the engine block can be used.

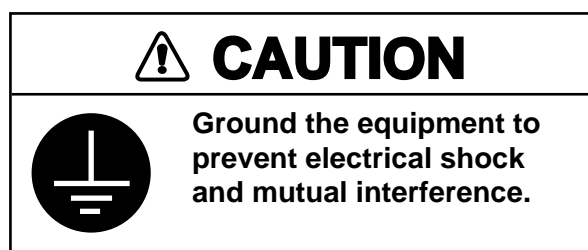

Note: Use a "closed" lug to make the ground connection at the display unit. Do not use an "open-type" lug ().

## Extending antenna cable length

The standard cable is 10 m long. For extension, in case of the GPA-019S or GPA-017S, an antenna cable set of 15 m, 30 m or 50 m is available. Extension cable cannot be used with the GPA-017 or GPA-019.

Cable length	Necessary parts	Code No.
15 m	TNC-PS-3D-15	000-133-670
30 m	CP20-01700	004-372-110
50 m	CP20-01710	004-372-120

### Extension cable line-up (in case of 15 m, 30 m or 50 m)

Fabricate the end of the antenna cable and attach the coaxial connector. Details are shown on next page.

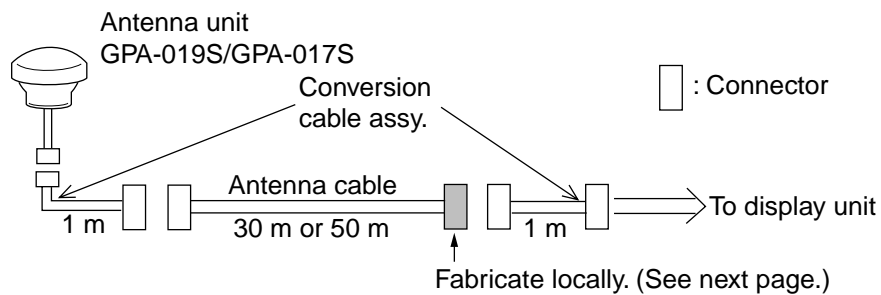

*Cable extension (CP20-01700, CP20-01710)*

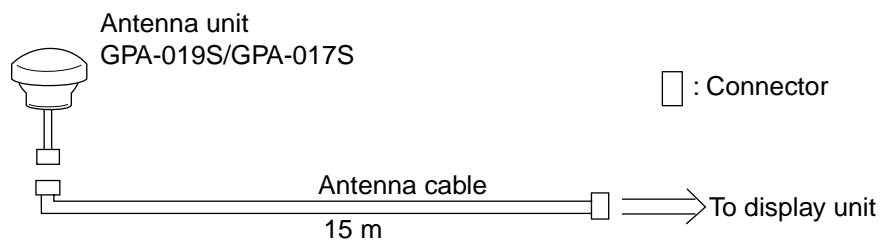

*Cable extension (TNC-PS-3D-15)*

### Waterproofing connector

Wrap connector with vulcanizing tape and then vinyl tape. Bind the tape end with cable-tie.



*Waterproofing connector*

**How to attach the N-P-8DFB connector**

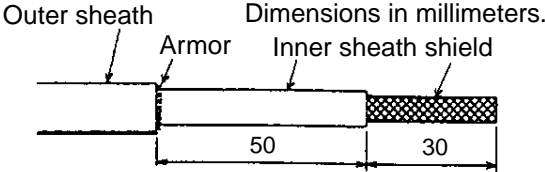

Remove outer sheath and armor by the dimensions shown left.  
Expose inner sheath and shield by the dimensions shown left.

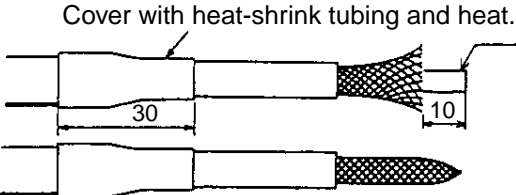

Cut off insulator and core by 10mm.

Twist shield end.

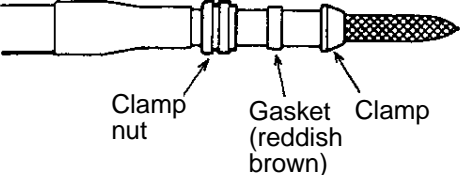

Ship on clamp nut, gasket and clamp as shown left.

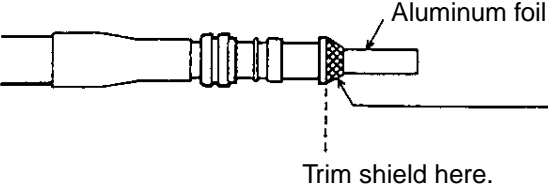

Fold back shield over clamp and trim.



Cut aluminum foil at four places, 90° from one another.

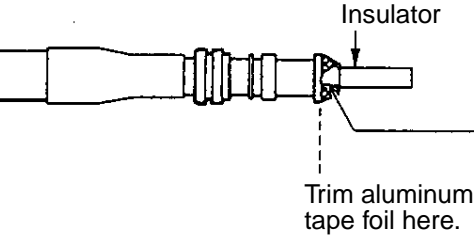

Fold back aluminum foil onto shield and trim.



Expose the insulator by 1mm.

Expose the core by 5mm.

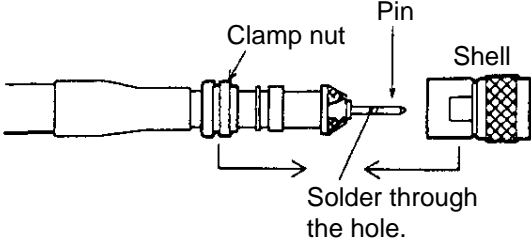

Slip the pin onto the conductor. Solder them together through the hole on the pin.

Insert the pin into the shell. Screw the clamp nut into the shell.  
(Tighten by turning the clamp nut. Do not tighten by turning the shell.)

## 2. WIRING

This page is intentionally left blank.

# 3. INITIAL SETTINGS

---

## 3.1 NMEA Setting

### NMEA port

This setting should be done when connecting with other equipment, autopilot, radar or remote display.

1. Press the [MENU] key.
2. Press the CONFIGURATION soft key.
3. Press the SETUP NMEA PORT1 soft key.
4. Press the cursor pad to select FORMAT.
5. Press the EDIT soft key to display the following window.

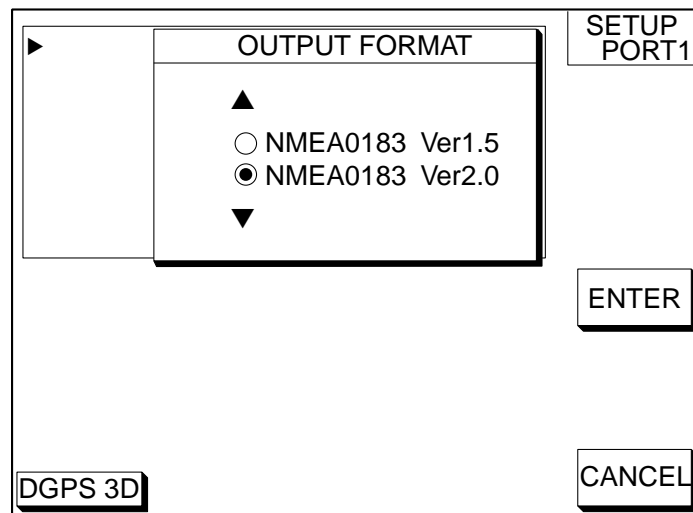

*Output format window (PORT 1)*

6. Select NMEA version depending on the specification of the equipment connected. The selected item is indicated by black button.
7. Press the ENTER soft key.
8. Press the [PLOT] key to return to the plotter display.

### 3. INITIAL SETTINGS

## DGPS port

Set the following when connecting with DGPS beacon receiver GR-80 or the DGPS beacon receiver is incorporated, PC to the DGPS port.

**Note:** Signal level for DGPS port is RS232C.

1. Press the [MENU] key.
2. Press the CONFIGURATION soft key.
3. Press the SETUP NMEA/DGPS PORT 2 soft key.
4. Select FORMAT, and then press the EDIT soft key.

The following window appears.

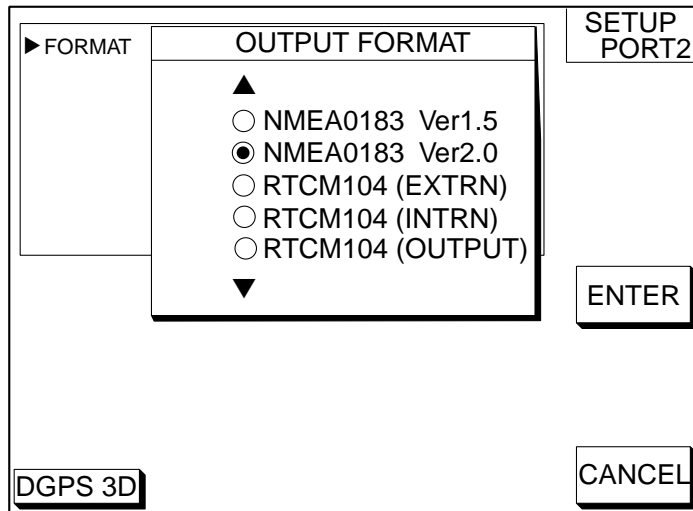

*Output format window (PORT 2)*

5. Select NMEA version. The selected item is indicated by black button.  
NMEA0183 Ver1.5/2.0: Select one when connecting PC or RS-232C equipment.  
RTCM104 (EXTERN): Select this when connecting external DGPS beacon receiver.  
RTCM104 (INTRN): Select this for built in internal DGPS beacon receiver.  
RTCM104 (OUTPUT): Select this when outputting differential data of the internal DGPS beacon receiver to other GPS navigator.

**Note 1:** Note that you cannot setup sentences when you select RTCM104 at the format.

**Note 2:** For RS-422 format, the level converter (IF-1432) is required for connection of external equipment.

6. Press the ENTER soft key.
7. Press the [PLOT] key to finish.

## 3.2 Output Data Sentences

Select output data sentences for external equipment as follows.

1. Press the [MENU] key.
2. Press the CONFIGURATION soft key.
3. Press the SETUP NMEA PORT1 soft key.
4. Press the SELECT SNTNC. soft key to display the SELECT SENTENCE window.

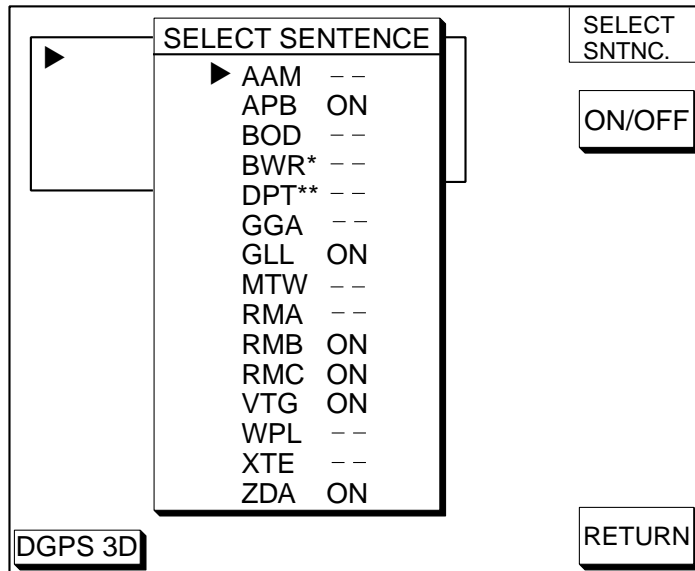

\*: BWR for Rhumb line  
BWC for Great circle  
\*\*: DPT for NMEA0183 Ver. 2.0  
DBT for NMEA0183 Ver. 1.5

*Select sentence window*

5. Select data sentence you want to output.
6. Press the ON/OFF soft key. To output data, select ON.
7. Repeat to select other sentences.
8. Press the RETURN soft key.
9. Press the [PLOT] key to return the plotter display.

### 3. INITIAL SETTINGS

#### Input/Output data sentences

Port		Format	Data	Remarks
NMEA	Input	NMEA-0183 Ver. 2.0 Ver. 1.5 IEC1162	TLL*1, DMM, WPL*1, DBT/DPT	WPL: GP only NMEA Ver 1.5: DBT NMEA Ver 2.0: DPT
	Output		AAM, APB, BOD, BWC/BWR, GGA, GLL, RMA, RMB, RMC, VTG, WPL, XTE, ZDA, MTW, GTD*2	GREAT CIRCLE: BWC RHUMB LINE: BWR
DGPS	Input	NMEA-0183 Ver. 2.0 Ver. 1.5 RS232C RTCM104	TLL*1, MTW, WPL*1, DBT/DPT	WPL: GP only NMEA Ver 1.5: DBT NMEA Ver 2.0: DPT
	Output		AAM, APB, BOD, BWC/BWR, GGA, GLL, RMA, RMB, RMC, VTG, WPL, XTE, ZDA, MTW, GTD*2	GREAT CIRCLE: BWC RHUMB LINE: BWR

\*1: Cannot be input consecutively.

\*2: Output automatically when LC or LA is selected.

### 3.3 Antenna Height

Enter height of antenna above water. (Default setting: 5 m)

1. Press the [MENU] key.
2. Press the GPS/DGPS/TD OPTIONS soft key.
3. Press the GPS SETUP OPTIONS soft key.
4. Select ANT. HEIGHT.
5. Press the EDIT soft key.

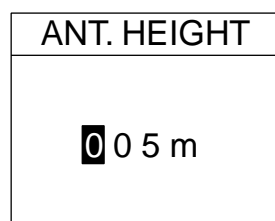

*Ant. height window*

6. Enter the height (3 digits) of the antenna above sea level using the numeric keys.  
If you enter wrong antenna height, press the CLEAR soft key.
7. Press the ENTER soft key.
8. Press the [PLOT] key to return the plotter display.



### 3.4 DGPS Setting

When external DGPS beacon receiver (RS-232C only) is connected or the DGPS beacon receiver is incorporated, set the DGPS mode referring to the following procedure.

1. Press the [MENU] key.
2. Press the GPS/DGPS/TD OPTIONS soft key.
3. Press the DGPS/WAAS SETUP OPTIONS soft key.

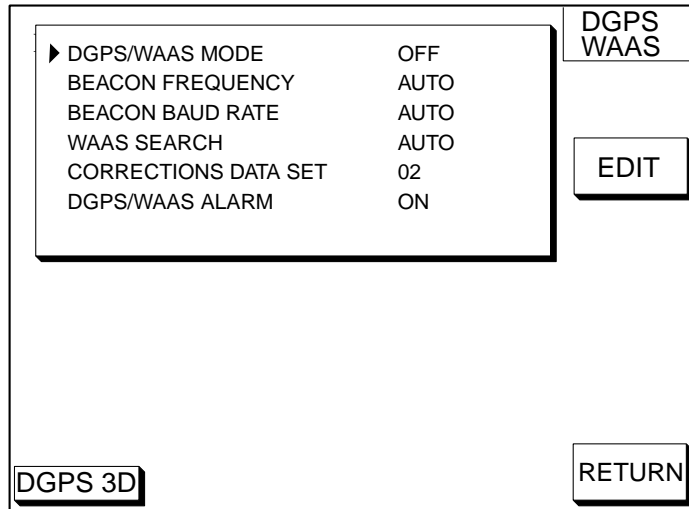

DGPS options window

4. Select DGPS/WAAS MODE and press the EDIT soft key.
5. Select DGPS or AUTO and press the ENTER soft key.  
 WAAS: WAAS data can be received.  
 AUTO: DGPS, WAAS or GPS data can be automatically received, The order of priority is DGPS, WAAS and GPS.

Note: If the external DGPS beacon receiver GR-80 is connected to the GP-1650WF, refer to the interconnection diagram below.

Connection with GR-80

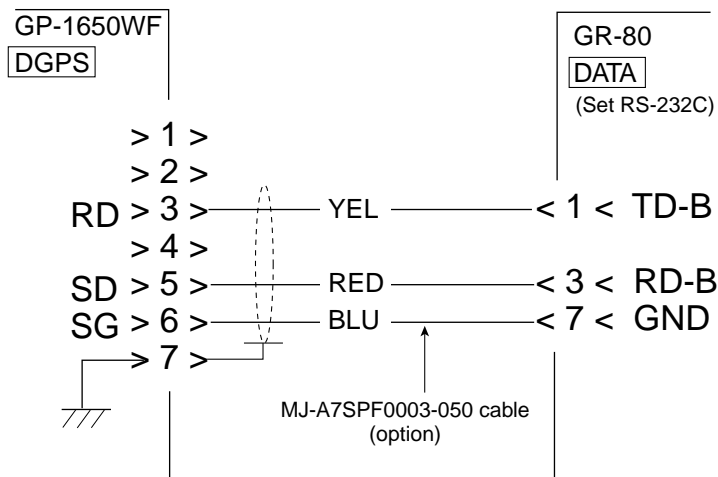

### 3. INITIAL SETTINGS

6. Select BEACON FREQUENCY by the cursor pad.
7. Press the EDIT soft key to display the following window.

BEACON FREQUENCY	
▲	
<input checked="" type="radio"/>	AUTO
<input type="radio"/>	MANUAL ▶ 284.0 kHz
▼	

*Beacon frequency window*

8. Select AUTO or MANUAL by the cursor pad. When you select MANUAL, operate the cursor pad to move the cursor to frequency dialog box. And press the cursor pad to select the frequency desired.

AUTO: DGPS reference station can be searched automatically.

9. Press the [ENTER] key.
10. Select BEACON BAUD RATE by the cursor pad.
11. Press the EDIT soft key to display the following window. Beacon baud rate cannot be set when BEACON FREQUENCY is set to AUTO.

BEACON BAUD RATE	
▲	
<input type="radio"/>	200
<input checked="" type="radio"/>	100
<input type="radio"/>	50
▼	

*Beacon baud rate window*

12. Select beacon baud rate corresponding to DGPS reference station to use.
13. Press the [ENTER] key.
14. Press the [PLOT] key to return the plotter display.

## 3.5 External Equipment Setup (Option)

This section shows you how to set up the GP-1650WF/WDF when external equipment is connected. If a water temperature/speed sensor is installed, you should complete this section with the boat in the water and running, to confirm speed/water temperature readout.

### Speed Source

1. Press the [MENU] key.
2. Press the DISPLAY OPTIONS, NEXT PAGE soft keys to show the DISPLAY SETUP2 menu.

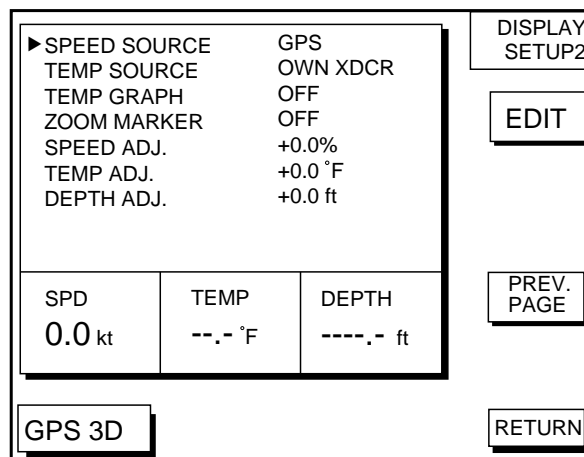

*Display setup 2 menu*

3. Select SPEED SOURCE, EDIT soft keys to show the SPEED SOURCE window.

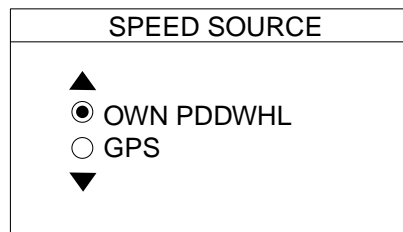

*Speed source window*

4. Select source of speed; OWN PDDWHL (speed sensor) or GPS.  
The selected item is indicated by black button. Adjust speed when you select OWN PDDWHL. Refer to Speed Adjustment shown below.
5. Press the ENTER soft key.

### 3. INITIAL SETTINGS

## Speed Adjustment

For speed sensor-equipped sets, you may offset the speed readout if it is wrong. Run the boat at various speeds and watch the speed readout at the bottom of the screen. If it is unreasonably wrong, adjust the temperature readout as follows. Adjust speed when you select own speed source OWN PDDWHL.

1. At the DISPLAY SETUP 2 menu, select SPEED ADJ.
2. Press the EDIT soft key to display the SPEED ADJ window.



*Speed adj window*

3. Correct speed readout. The adjustment range is  $-50\%$  to  $+50\%$ . For example, if readout is 10% lower than actual speed, enter  $+10\%$ .
4. Press the RETURN soft key.

## Temperature Adjustment

For water temperature sensor-equipped sets, you may offset the water temperature readout if it is wrong. Watch the watertemperature readout at the bottom of the screen. If it is unreasonably wrong, adjust the temperature readout as follows.

1. At the DISPLAY SETUP 2 menu, select TEMP ADJ.
2. press the EDIT soft key to display the TEMP ADJ window.

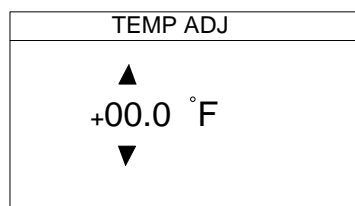

*Temp adj. Window*

3. Correct water temperature readout. The adjustment range is  $-99.9^{\circ}$  to  $+99.9^{\circ}\text{F}$ . For example, if the readout is  $2^{\circ}$  higher than actual temperature, enter  $-2^{\circ}$ .
4. Press the RETURN soft key.

# 4. INCORPORATION OF DGPS BEACON RECEIVER KIT (for GP-1650WF)

The DGPS beacon receiver GR-7000A can be incorporated in the GP-1650WF to provide it with DGPS capability. Two kinds of kit are available as shown.

## GR-7000A-1650-10N-019

Name	Type	Code No.	Qty
Antenna Unit	GPA-019	000-142-416	1
Beacon Receiver	GR-7000A	000-143-249	1
Connector Assy.	PH6P-W-L240	000-141-548	1
Pan head screws	M3X10 C2700W	000-881-405	4
Cable tie	CV-100	000-570-322	2
Screw	M3X12 SUS304	000-805-905	6
Cable Assy.	S.FL2-2LP0.7-D-WHT (121)	000-141-491	1
Clamp	HP-2N	000-570-000	1
Cable Assy.*	S.FL2-2LP0.7-D-WHT (250)	000-143-877	1
Screw*	3X8 SUS410	000-802-951	4
Cable Assy.	S.FL2-2LP0.7-D-WHT (175)	000-141-490	1

\* Not used

## GR-7000A-1650-15N-019S

Name	Type	Code No.	Qty
Antenna Unit	GPA-019S	000-142-545	1
Beacon Receiver	GR-7000A	000-143-249	1
Cable Assy.	TNC-PS-3D-15	000-133-670	1
Connector Assy.	PH6P-W-L240	000-141-548	1
Pan head screws	M3X10 C2700W	000-881-405	4
Cable tie	CV-100	000-570-322	2
Screw	M3X12 SUS304	000-805-905	6
Cable Assy.	S.FL2-2LP0.7-D-WHT (121)	000-141-491	1
Clamp	HP-2N	000-570-000	1
Cable Assy.*	S.FL2-2LP0.7-D-WHT (250)	000-143-877	1
Screw*	3X8 SUS410	000-802-951	4
Cable Assy.	S.FL2-2LP0.7-D-WHT (175)	000-141-490	1

\* Not used

## Disassembly

### Procedure

1. Turn off the power. Wait at least one minute before opening the cover, to allow capacitors to discharge.
2. Remove nuts attached to DGPS, XDR, NMEA and power supply connectors at the rear of the display unit.

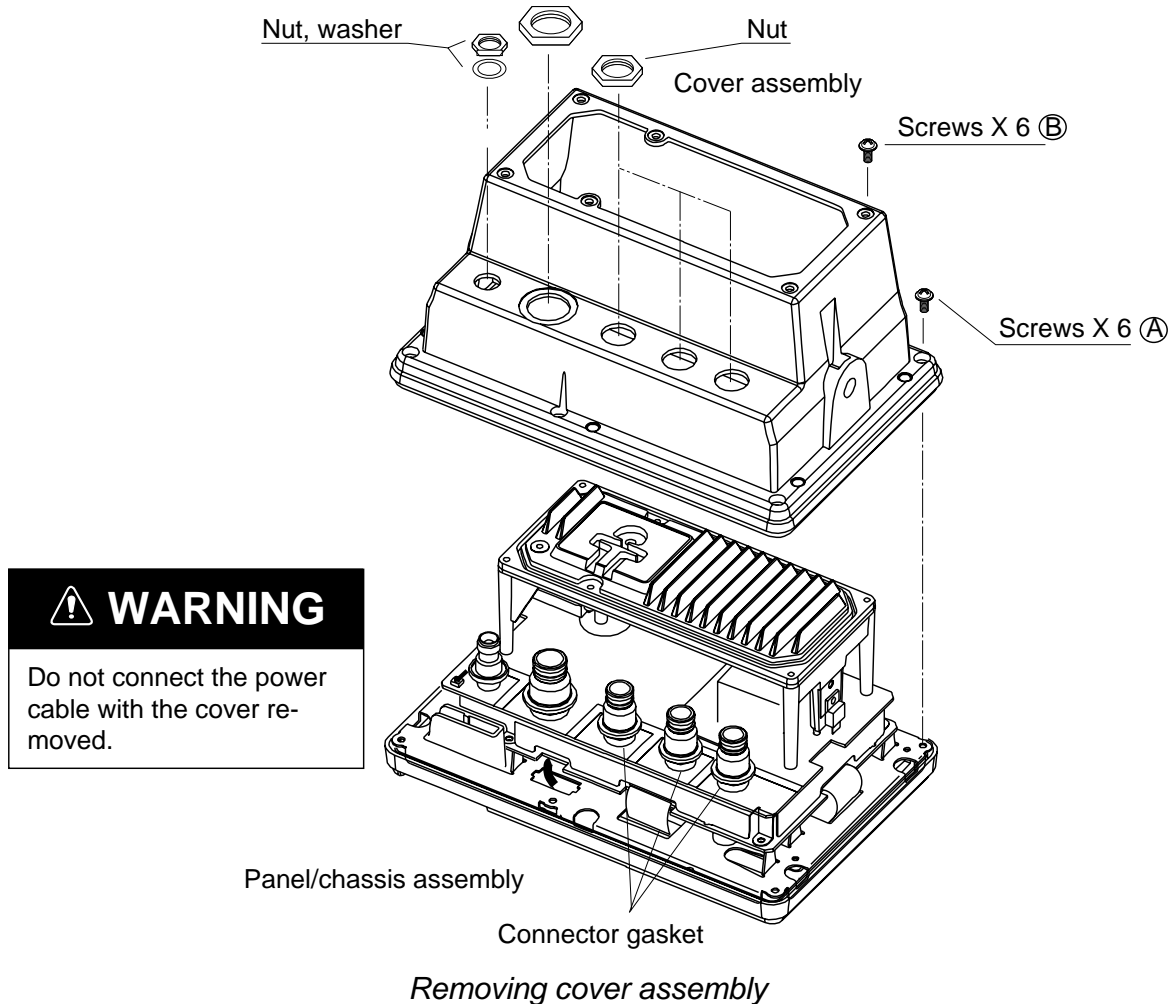

3. Remove nuts and washer attached to ANT connector.
4. Remove twelve screws at rear of the display unit to detach panel/chassis assembly from cover assembly.  
Discard six screws (A)(3X12).

## Installation of beacon receiver

### Procedure

1. Disconnect 8P connector as shown in the figure below.

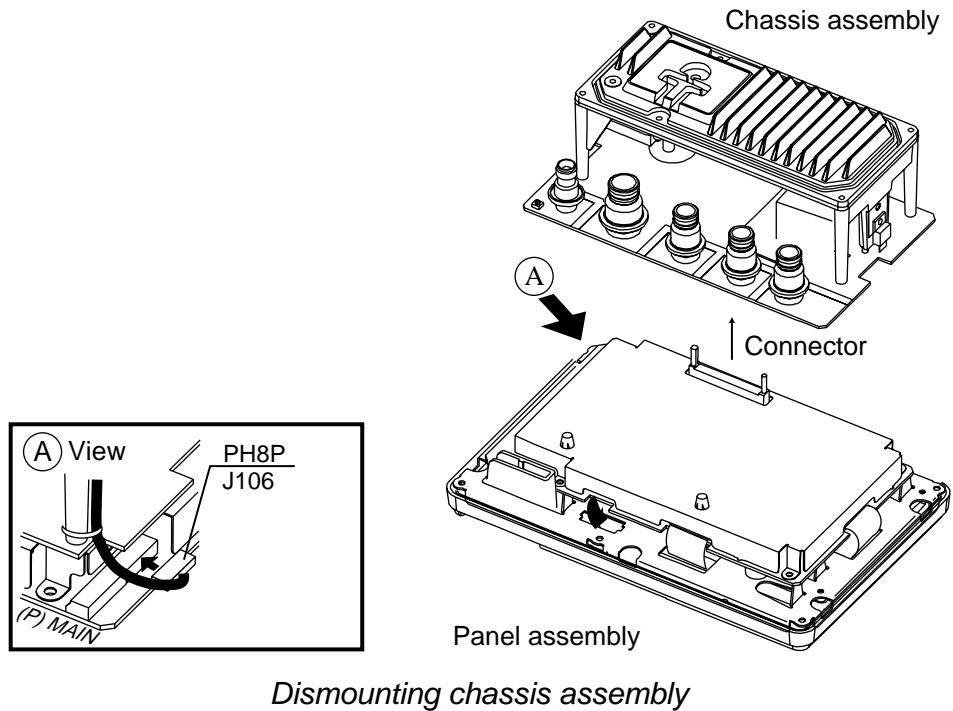

2. Dismount chassis assembly from panel assembly by disconnecting connector shown in the figure above.
3. Cut the cable ties as shown in the figure below.

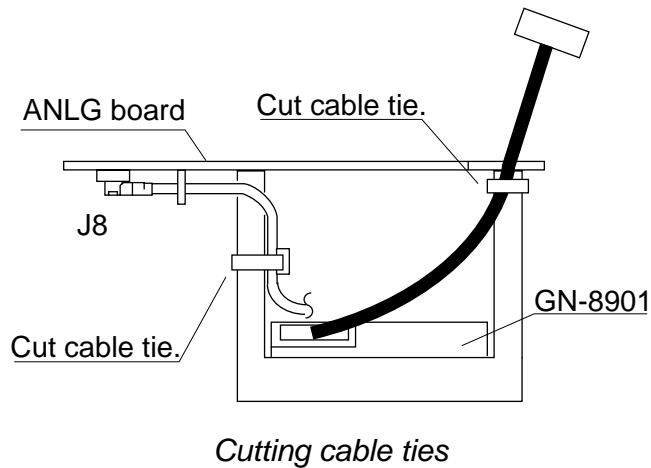

#### 4. INCORPORATION OF DGPS BEACON RECEIVER KIT (for GP-1650WF)

4. Dismount heat sink from chassis assembly by unfastening four screws on the ANLG board and disconnecting the connector of the mini pin coaxial cable.

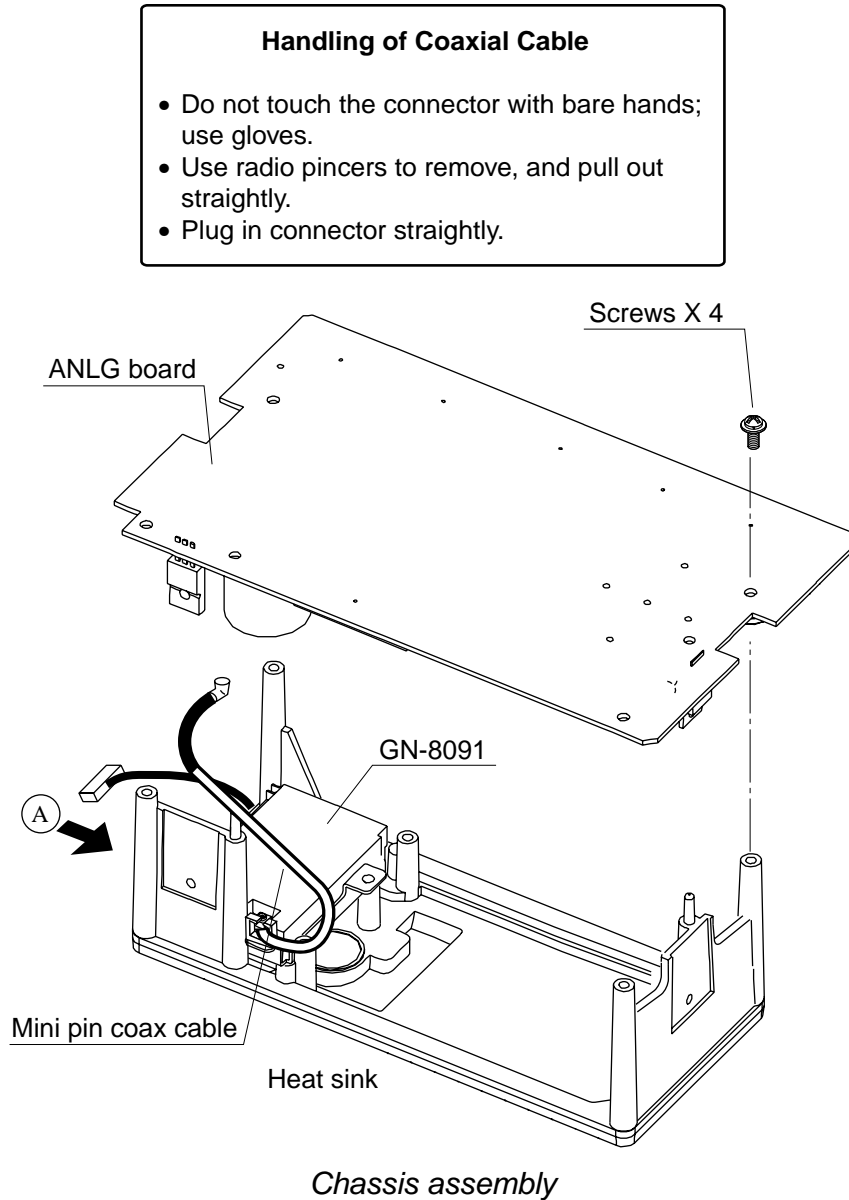

5. Take off the mini pin coaxial cable from J2 on the GN-8091.
6. Open the lid of GR-7000A
7. Connect cable assy. S.FL2-2LP0.7-D-WHT (175) (supplied) to J1 of GR-7000A



4. INCORPORATION OF DGPS BEACON RECEIVER KIT (for GP-1650WF)

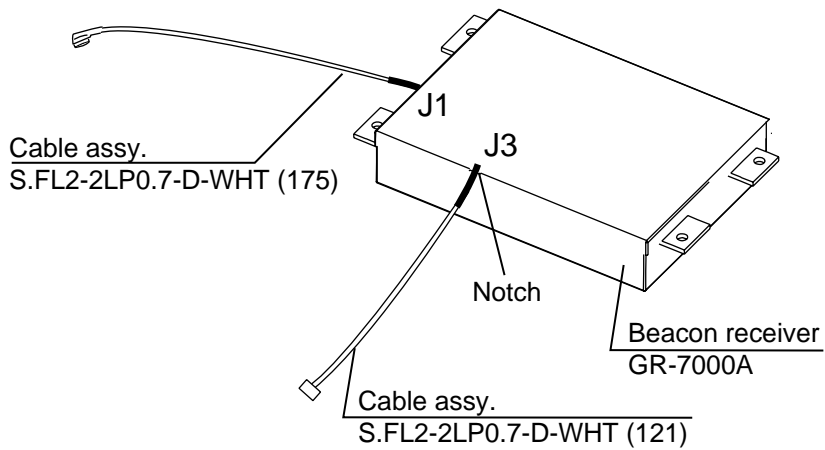

*Beacon receiver*

8. Connect cable assy. S.FL2-2LP0.7-D-WHT (121) (supplied) to J3 of the GR-7000A.
9. Close the lid of the GR-7000A.
10. Connect connector assy. PH6P-W-L240 to J2 of GR-7000A (Refer to the figure below).
11. Fasten the GR-7000A (Beacon receiver) to the heat sink with four M3X10 screws (supplied) as shown in the figure below.

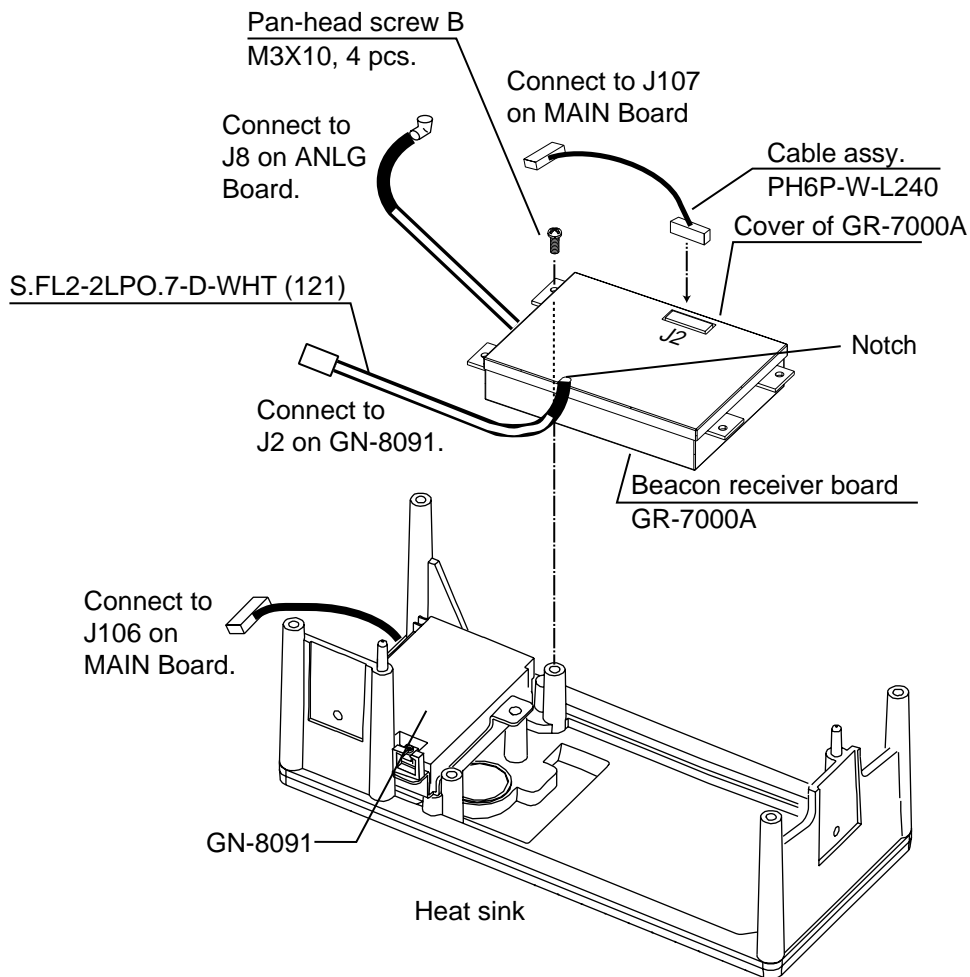

*Installation of DGPS beacon receiver*

4. INCORPORATION OF DGPS BEACON RECEIVER KIT (for GP-1650WF)

12. Connect the cable assy. S.FL2-2LP0.7-D-WHT (121) of J3 to J2 of the GN-8091.
13. Pass the mini pin coaxial cable of J1 on the GR-7000A through the mini plug on the ANLG Board and connect it to J8 on the ANLG Board.

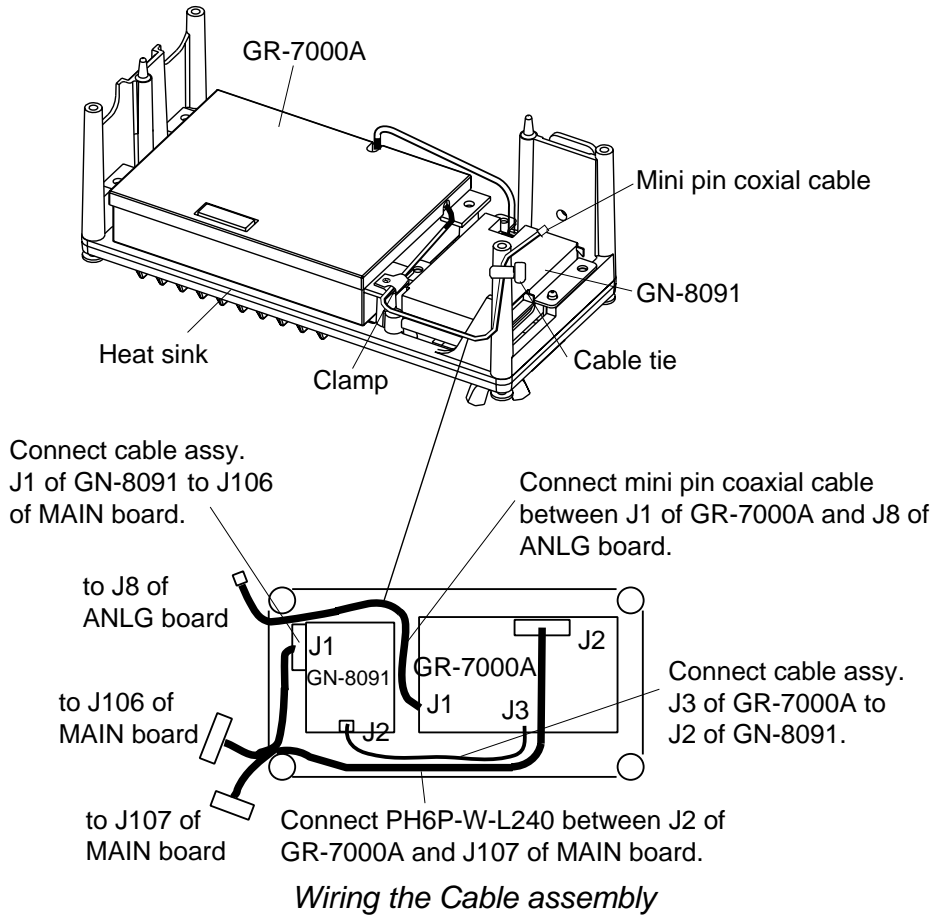

14. Mount the ANLG board on the heat sink.
15. Mount chassis assembly on the panel assembly. Connect 8P connector and 6P connector to Main board as shown in the figure below.

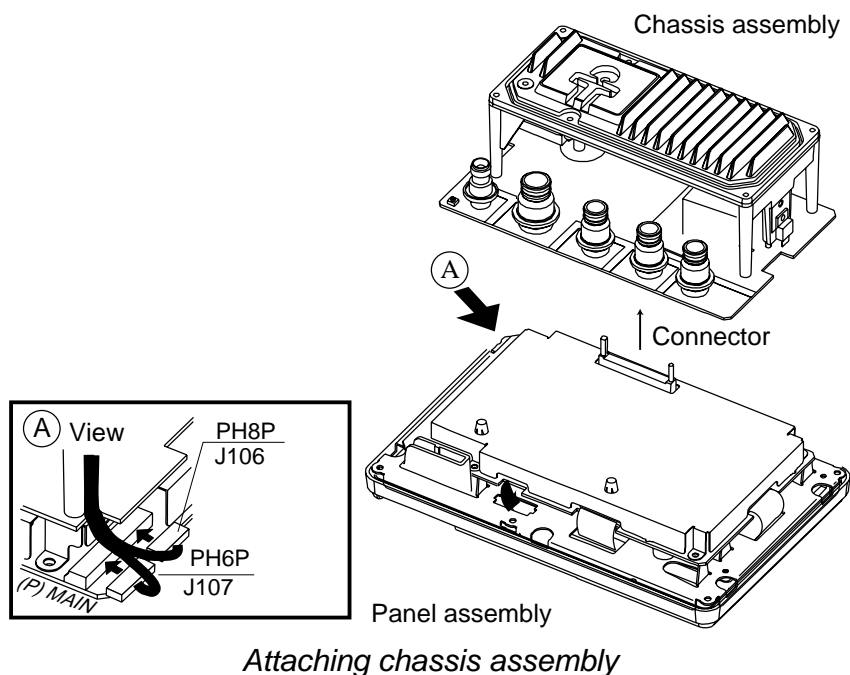

#### 4. INCORPORATION OF DGPS BEACON RECEIVER KIT (for GP-1650WF)

16. Fasten 8P connector cable and 6P connector cable by cable tie as shown in the figure below. Fasten mini pin coaxial cable by cable tie (CV-100, supplied) as shown in the figure below.

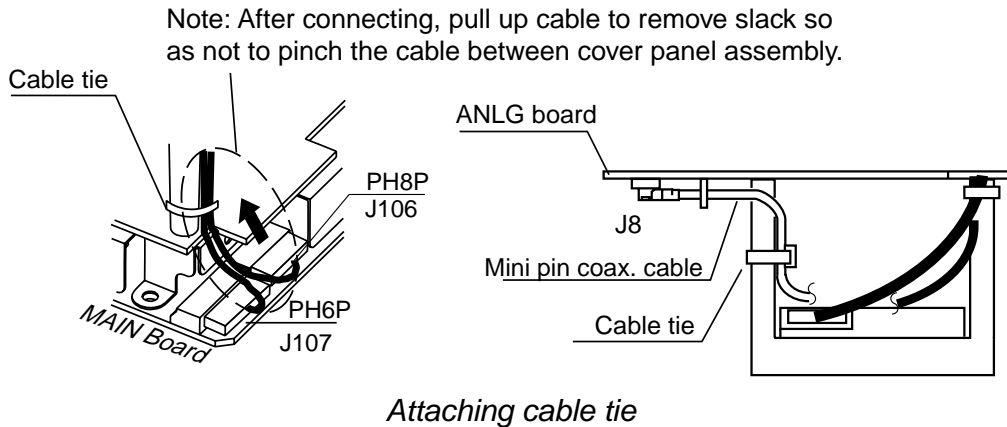

17. Reassemble the display unit.

Use new screws size 3X12 (supplied).

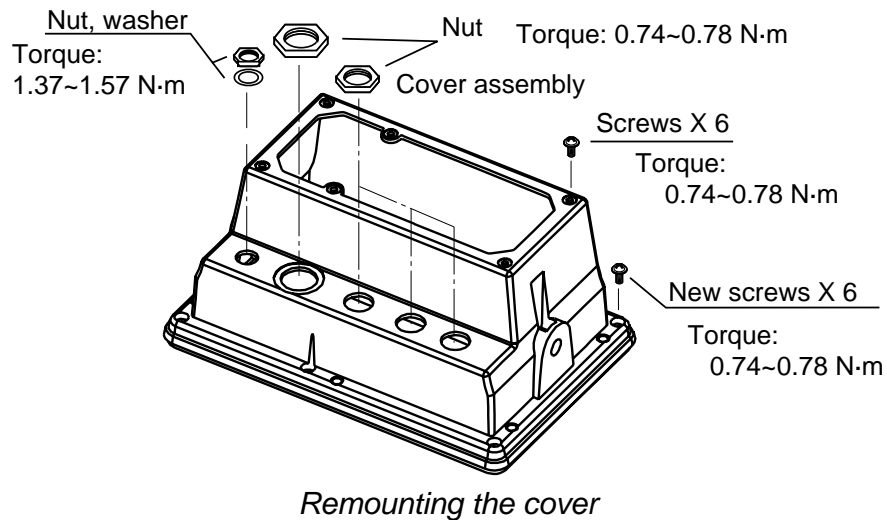

**Note:** When reattaching the cover, confirm the following parts are attached.

- Shield gasket, cover gasket (See the next page.)
- Connector gasket (See the page 4-2.)

4. INCORPORATION OF DGPS BEACON RECEIVER KIT (for GP-1650WF)

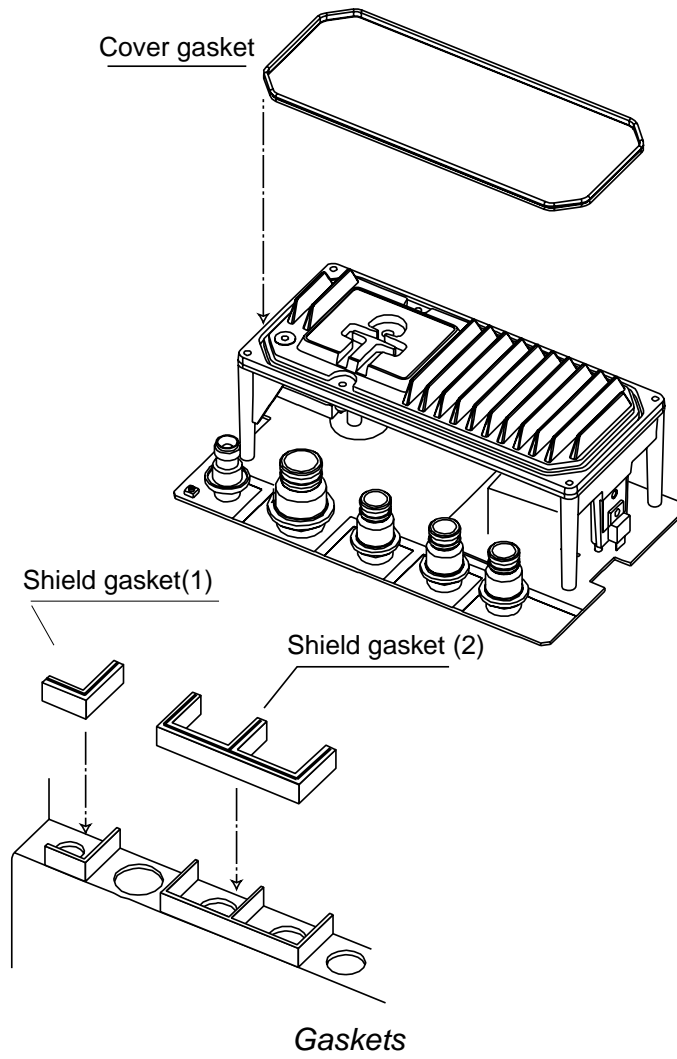

## Checking the beacon receiver

1. Press the [MENU] key.
2. Press the CONFIGURATION soft key.
3. Press the SYSTEM MENU soft key.
4. Press the SELF TEST soft key.
5. Press the MEMORY•I/O TEST soft key to display the following message.

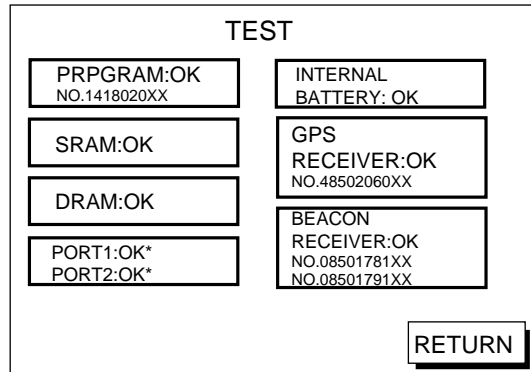

\*Special connections are required to check these ports. Otherwise, NG appears.

### *Memory, I/O Test Display*

6. Confirm that BEACON RECEIVER: OK is displayed.
7. Press the RETURN soft key.
8. Press the [PLOT] key to return the plotter display.

This page is intentionally left blank.

# PACKING LIST GP-1650W/WF (E017)

1400-X-9852-0 1/1

NAME	OUTLINE	DESCRIPTION/CODE No.	Q'TY
<b>ユニット UNIT</b>			
空中線部 ANTENNA UNIT		GPA-017	1
指示器 DISPLAY UNIT		000-041-403 GP-1650W-E	1
<b>予備品 SPARE PARTS</b>			
ヒューズ FUSE		SP14-02401 FGB0-A 3A AC125V	3
<b>付属品 ACCESSORIES</b>			
ハードカバー組品 HARD COVER ASSY.		FP14-02301	1
<b>付属品 ACCESSORIES</b>			
+トラスタップピンボ +TAPPING SCREW		FP14-02302 5X16 SUS304 1種	4
+ナハ セムスネジ WASHER HEAD SCREW		000-805-494 MAX20 SUS304	6
<b>その他工材 OTHER INSTALLATION MATERIALS</b>			
ケーブル組品 POWER CABLE		MJ-A3SPF0013-035 000-135-397	1

NAME	OUTLINE	DESCRIPTION/CODE No.	Q'TY
ケーブル組品MJ CABLE ASSY.		MJ-A6SPF0003-050 000-117-603	1

コート末尾に[\*\*]の付いたユニットは代表の型式/コードを表示しています  
DOUBLE ASTERISK DENOTES COMMONLY USED EQUIPMENT.

(略図の寸法は、参考値です。 DIMENSIONS IN DRAWING FOR REFERENCE ONLY.)

# PACKING LIST GP-1650WD/WDF (E019)

1400-X-9854-0 1/1

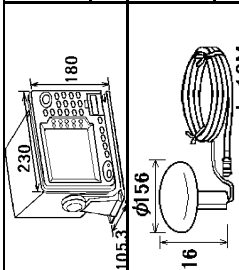
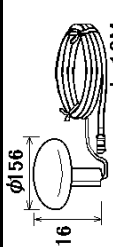
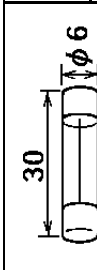
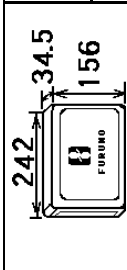
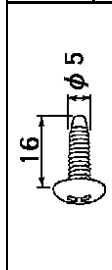
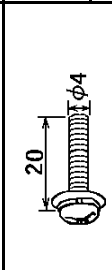
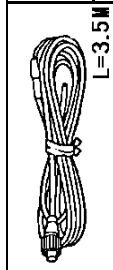
NAME	OUTLINE	DESCRIPTION/CODE No.	Q'TY
<b>ユニット UNIT</b>			
指示器 DISPLAY UNIT		GP-1650WD-E	1
空中線部 ANTENNA UNIT		000-041-796** GPA-019	1
<b>予備品 SPARE PARTS</b>			
フューズ FUSE		SP14-02401 FGB0-A 3A AC125V	3
<b>付属品 ACCESSORIES</b>			
ハードカバー組品 HARD COVER ASSY.		FP14-02301	1
<b>付属品 ACCESSORIES</b>			
+トラスタップ ンボ +TAPPING SCREW		FP14-02302 5X16 SUS304 1種	4
+ナハ セムスネジ B WASHER HEAD SCREW		000-805-494 MAX20 SUS304	6
<b>その他工材 OTHER INSTALLATION MATERIALS</b>			
ケーブル組品 POWER CABLE		000-804-742 MJ-A3SPF0013-035	1

NAME	OUTLINE	DESCRIPTION/CODE No.	Q'TY
ケーブル組品 MJ CABLE ASSY.		MJ-A6SPF0003-050 000-117-603	1



コート末尾に[\*\*]の付いたユニットは代表の型式/コードを表示しています  
DOUBLE ASTERISK DENOTES COMMONLY USED EQUIPMENT.

(略図の寸法は、参考値です。 DIMENSIONS IN DRAWING FOR REFERENCE ONLY.)

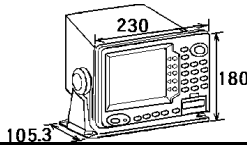
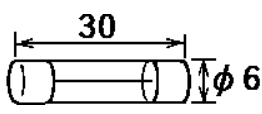
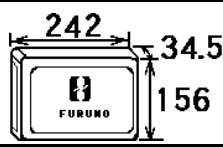
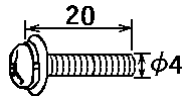
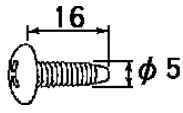

## PACKING LIST

GP-1650WD/WDF (E)



NAME	OUTLINE	DESCRIPTION/CODE No.	Q'TY
<b>ユニット</b> UNIT			
指示器 DISPLAY UNIT		GP-1650WD-E 000-041-796 **	1
<b>予備品</b> SPARE PARTS		<b>SP14-02401</b>	
ヒューズ FUSE		FGB0-A 3A AC125V 000-549-063	3
<b>付属品</b> ACCESSORIES		<b>FP14-02301</b>	
ハードカバー組品 HARD COVER ASSY.		FP14-02301 004-375-830	1
<b>付属品</b> ACCESSORIES		<b>FP14-02302</b>	
+ナベセムスネジ B WASHER HEAD SCREW		M4X20 SUS304 000-804-742	6
+トラスタップソネジ +TAPPING SCREW		5X16 SUS304 1種 000-805-494	4
<b>その他工材</b> OTHER INSTALLATION MATERIALS			
ケーブル組品MJ CABLE ASSY.		MJ-A6SPF0003-050 000-117-603	1
ケーブル組品 POWER CABLE		MJ-A3SPF0013-035 000-135-397	1

コード末尾に[\*\*]の付いたユニットは代表の型式/コードを表示しています  
DOUBLE ASTERISK DENOTES COMMONLY USED EQUIPMENT.

(略図の寸法は、参考値です。 DIMENSIONS IN DRAWING FOR REFERENCE ONLY.)

**FURUNO**

CODE NO.		20AG-X-9404 -1
TYPE		1/1

工事材料表 INSTALLATION MATERIALS		GP-80, GP-90, SC-55, GP-3500/F GP-1850, GP-1650, FA-100, GP-1640/F SC-60/120, GD/GP-280/680/380			
番号 NO.	名称 NAME	略図 OUTLINE	型名 / 規格 DESCRIPTIONS	数量 Q'TY	用途 / 備考 REMARKS
1	アンテナケーブル組品 ANTENNA CABLE ASSY.	 L=30M	8D-FB-CV *30M*	1	選択 TO BE SELECTED
			CODE NO.		
2	ケーブル組品 CABLE ASSY.	 L=50M	8D-FB-CV *50M*	1	選択 TO BE SELECTED
			CODE NO.		

FURUNO ELECTRIC CO., LTD.  
(略図の寸法は、参考値です。 DIMENSIONS IN DRAWING FOR REFERENCE ONLY.)

**FURUNO**

CODE NO.	004-372-420	20AG-X-9405 -1 1/1
TYPE	CP20-01701	

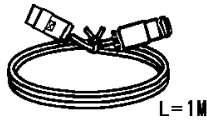
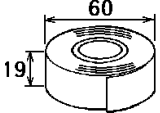
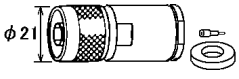
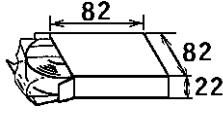
工事材料表 INSTALLATION MATERIALS					
番号 NO.	名称 NAME	略図 OUTLINE	型名/規格 DESCRIPTIONS	数量 Q'TY	用途/備考 REMARKS
1	変換ケーブル組品 CONVERT CABLE ASSY.		NJ-TP-3DXV-1	2	
			CODE NO.		
2	ビニールテープ VINYL TAPE		N0360 02X19X10000 加 工品	1	
			CODE NO.		
3	コネクタ(N) CONNECTOR		N-P-8DFB	1	
			CODE NO.		
4	絶縁テープ SELF-BONDING TAPE		Uテープ 0.5X19X5M	1	
			CODE NO.		

(略図の寸法は、参考値です。 DIMENSIONS IN DRAWING FOR REFERENCE ONLY.)

FURUNO ELECTRIC CO., LTD.



表 1 TABLE 1

寸法区分 (mm) DIMENSION	公差 (mm) TOLERANCE
L ≤ 50	± 1.5
50 < L ≤ 100	± 2.5
100 < L ≤ 500	± 3

表 2 TABLE 2

機種名 MODEL	質量 MASS(kg)
GP-1650WF	2.2
GP-1650WDF	2.3

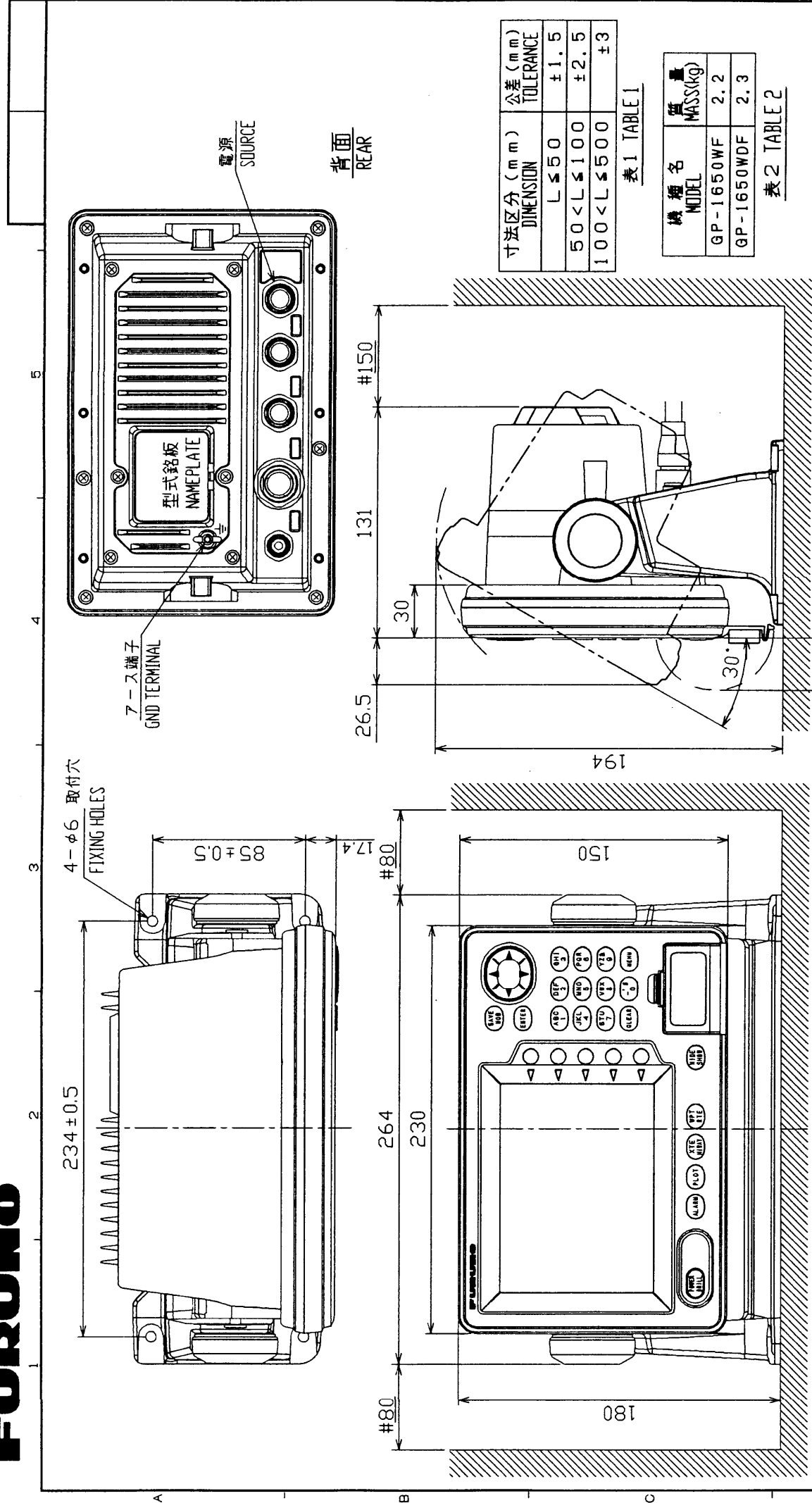
注記 1) 装着ケーブルはサービス時、本体を前方に十分引き出せるよう余裕を持たせること。  
 2) 取付用ネジはトラスタッピングネジ呼び径5×20を使用のこと。  
 3) 指定外寸法公差は、表1による。  
 4) #印寸法は最小サービス空間とする。

NOTE 1. KEEP SUFFICIENT CABLE LENGTH BEHIND UNIT.  
 2. USE TAPPING SCREWS 5x20 FOR FIXING THE UNIT.  
 3. TABLE 1 INDICATES TOLERANCE OF DIMENSIONS.  
 4. # RECOMMENDED SERVICE CLEARANCE.

DRAWN	JULY 9 '02	I. YAMASAKI	TITLE	GP-1650WF/1650WDF
CHECKED	JULY 9 '02	Y. KIKUCHI	名#	指示器
APPROVED	JULY 9 '02	Y. KIKUCHI		外寸図
SCALE	1/3	MASS 表 2	NAME	DISPLAY UNIT
DWG. No.	C4424-G03-A			OUTLINE DRAWING
	14-062-140G-0			

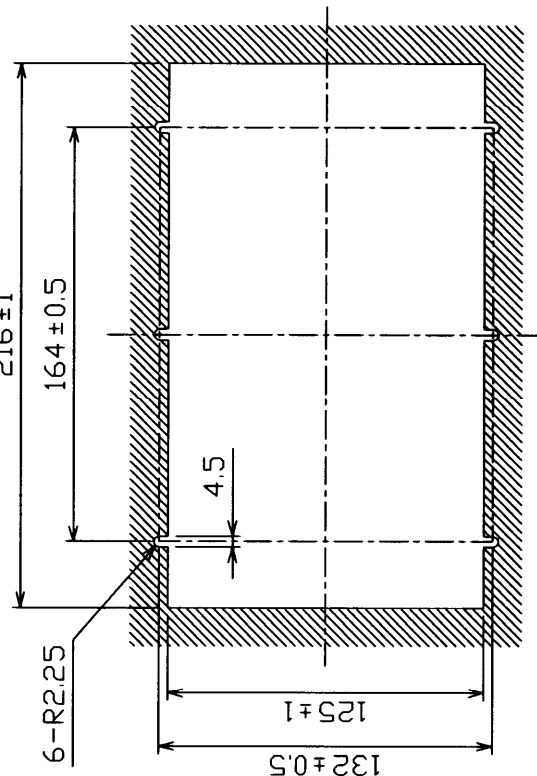
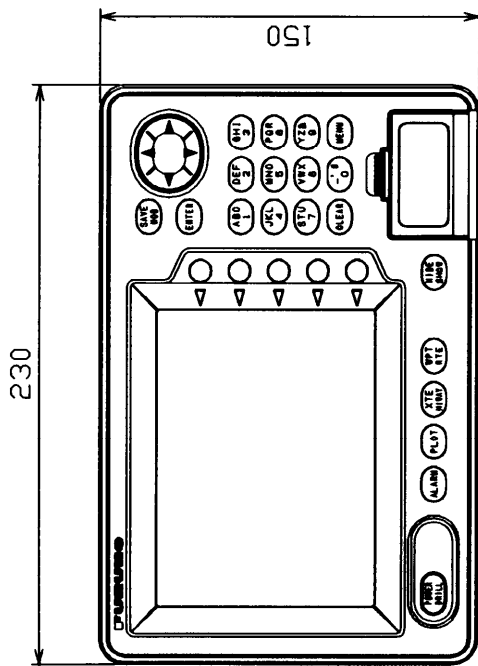

取付穴寸法図  
CUTOUT DIMENSIONS

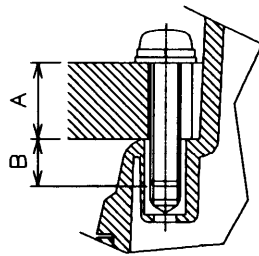
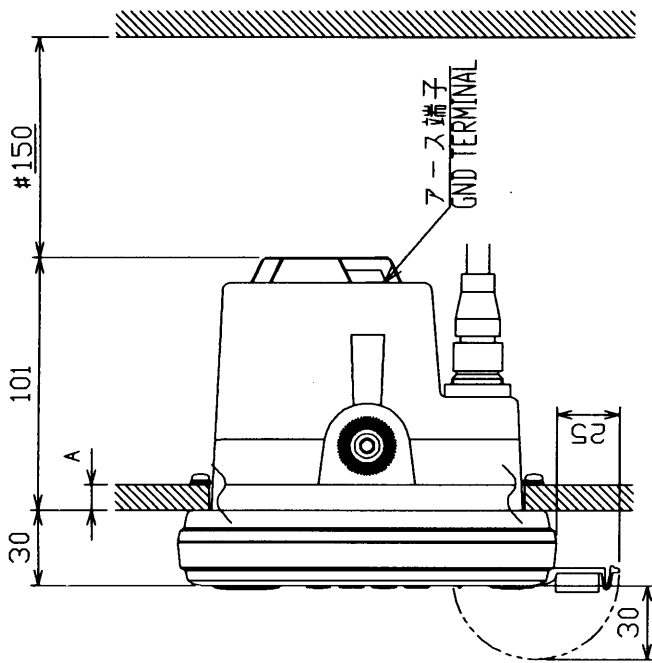

取付ネジ部断面  
(尺度 1/1)  
DETAIL FOR FASTENING (SCALE: 1/1)

- 注記
- 1) 指定外寸法公差は表 1 による。
  - 2) #印寸法は最小サービスペースとする。
  - 3) 取付用ネジは、セムネジ B M4×2.0 を使用のこと。  
壁の厚さ (A) は  $1.1 \leq A \leq 1.4$  とする。それ以外の壁に装備する  
場合、使用するネジ長さは  $(A + 7.8) \pm 1.5$  とする。それ以外の壁に装備  
する  
壁体にはネジ部を 8 mm 以上いれないこと。

NOTE

1. TABLE 1 INDICATES TOLERANCE OF DIMENSIONS.
2. # RECOMMENDED SERVICE CLEARANCE.
3. USE SEMS SCREWS M4x2.0 FOR FIXING THE UNIT.  
THICKNESS A:  $1.1 \leq A \leq 1.4$  OR SCREW LENGTH:  $(A+7.8) \pm 1.5$ .  
DO NOT FASTEN SCREWS INTO UNIT MORE THAN 8 mm.

機種名 MODEL	質量 MASS(kg)
GP-1650W	1.7
GP-1650WD	1.9
GP-1650WF	1.9
GP-1650WDF	2.0

表 2 TABLE 2

寸法区分 (mm) DIMENSIONS	公差 (mm) TOLERANCE
$L \leq 50$	$\pm 1.5$
$50 < L \leq 100$	$\pm 2.5$
$100 < L \leq 500$	$\pm 3$

表 1 TABLE 1

DRAWN	Aug. 29 '82	T. YAMASAKI	TITLE	GP-1650W/1650WD/1650WF/1650WDF
DESIGN	Aug. 28 '82	T. Kishida	名称	指示器
APPROVED	Aug. 29 '82	Y. I. I.		外寸図
SCALE	1/3	表 2	WVE	DISPLAY UNIT
DWG. No.	C4424-G02-B			OUTLINE DRAWING
	14-062-150G-0			

A

B

C

D

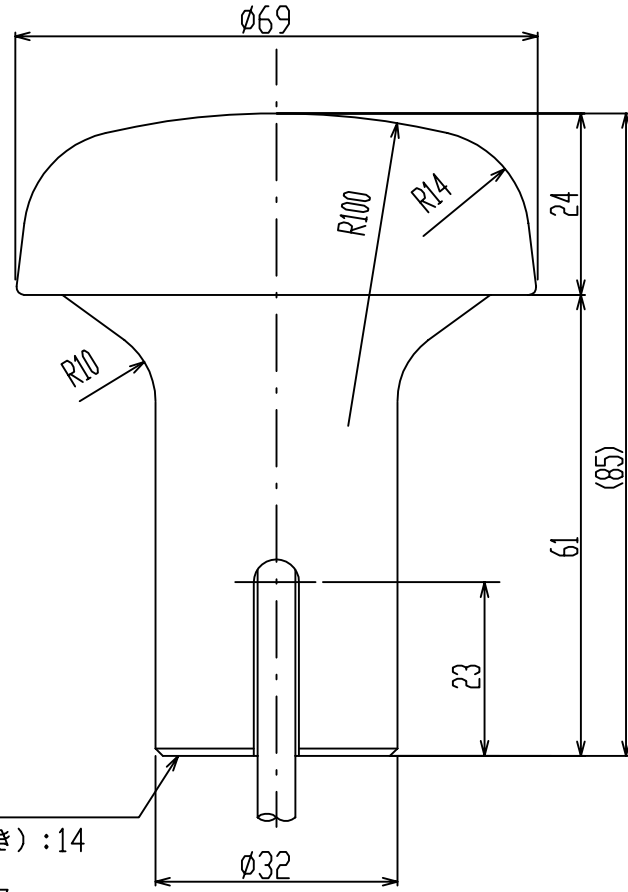

寸法区分(mm) DIMENSION	公差(mm) TOLERANCE
L ≤ 50	±1.5
50 < L ≤ 100	±2.5
100 < L ≤ 500	±3

表1 TABLE 1

1-14UNS1B

ねじ山数 (25.4mmにつき) : 14  
 ピッチ : 1.8143 mm  
 オネジ有効長さ : 24.17 mm  
 オネジ有効径 : 19 mm以上  
 THREAD PER 25.4mm (1 INCH): 14  
 PITCH: 1.8143 mm  
 THREAD LENGTH: 15.17 mm  
 PITCH DIAMETER: 24.17 mm

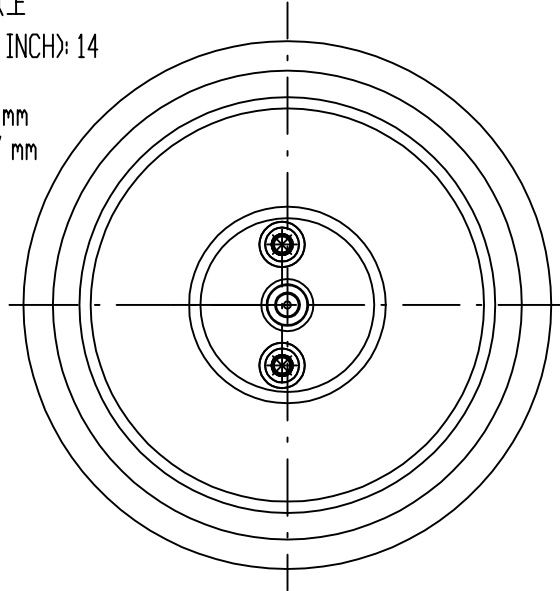

注記

指定外の寸法公差は表1による。

NOTE

TABLE 1 INDICATES TOLERANCE OF DIMENSIONS.

型式 TYPE	ケーブル長(m) CABLE LENGTH	プラグ PLAG	質量(kg±10%) MASS
GPA-017	10	TNC-P-3	0.6
GPA-017S	0.2	TNC-J-3	0.15

表2 TABLE 2

DRAWN Feb. 19 '03 T.YAMASAKI	TITLE GPA-017/017S
CHECKED Feb. 19 '03 Y.KIMURA	名称 空中線部
APPROVED Feb. 19, '03 <i>Y. Kimura</i>	外寸図
SCALE 1/1 MASS TABLE 2 表2参照	NAME ANTENNA UNIT
DWG.No. C4384-G04-J	OUTLINE DRAWING

寸法区分(mm) DIMENSION	公差(mm) TOLERANCE
L ≤ 50	±1.5
50 < L ≤ 100	±2.5
100 < L ≤ 500	±3

表1 TABLE 1

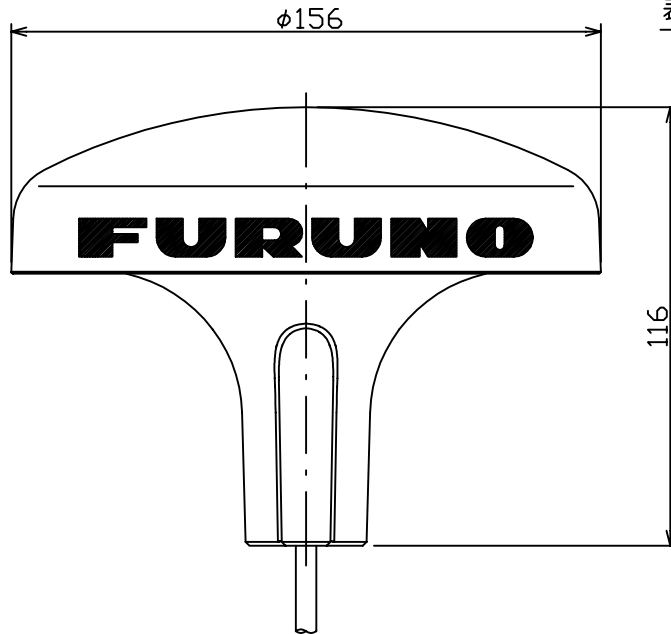

1-14UNS1B

ねじ山数(25.4mmにつき): 14  
 ピッチ: 1.8143 mm  
 オネジ有効長さ: 15.17 mm  
 オネジ有効径: 24.17 mm

THREAD PER 25.4mm (1 INCH): 14  
 PITCH: 1.8143 mm  
 THREAD LENGTH: 15.17 mm  
 PITCH DIAMETER: 24.17 mm

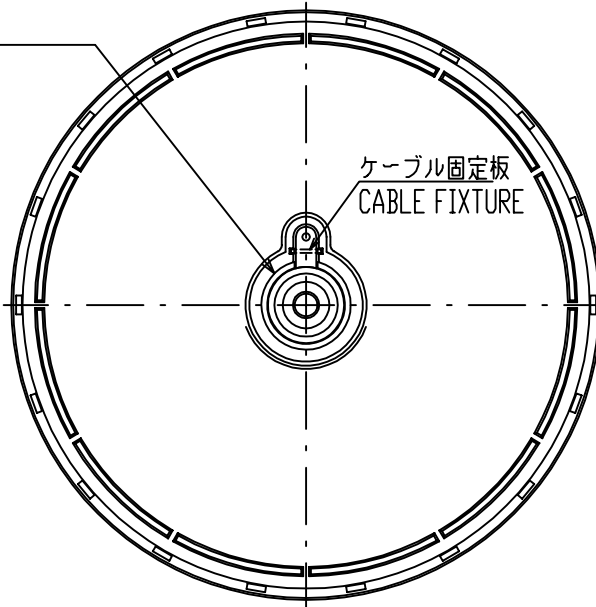

型式 TYPE	ケーブル長(m) CABLE LENGTH	プラグ PLAG	質量 (kg±10%) MASS
GPA-019	10	TNC-P-3	1.0
GPA-019S	0.2	TNC-J-3	0.54

表2 TABLE 2

注記: 指定外の寸法公差は表1による

NOTE: TABLE 1 INDICATES TOLERANCE OF DIMENSIONS.

DRAWN Feb. 19 '03 T.YAMASAKI	TITLE GPA-019/019S
CHECKED Feb. 19 '03 Y.KIMURA	名称 空中線部
APPROVED Feb. 19, '03 <i>Y. Kimura</i>	外寸図
SCALE 1/2 MASS TABLE 2 表2参照	NAME ANTENNA UNIT
DWG. No. C4400-G01-F	OUTLINE DRAWING







表1 TABLE 1

寸法区分(mm) DIMENSION	公差(mm) TOLERANCE
0 < L ≤ 50	±1.5
50 < L ≤ 100	±2.5
100 < L ≤ 500	±3

ケーブル導入口  
CABLE ENTRY

24VDC  
OUTPUT  
(2.5A max)

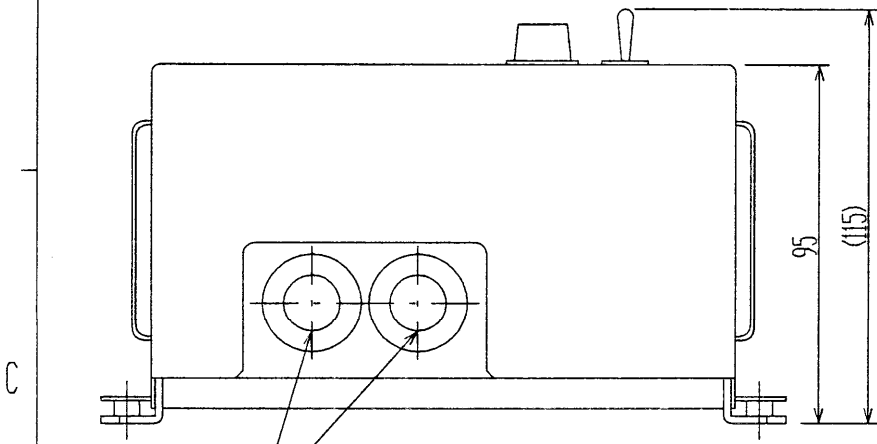
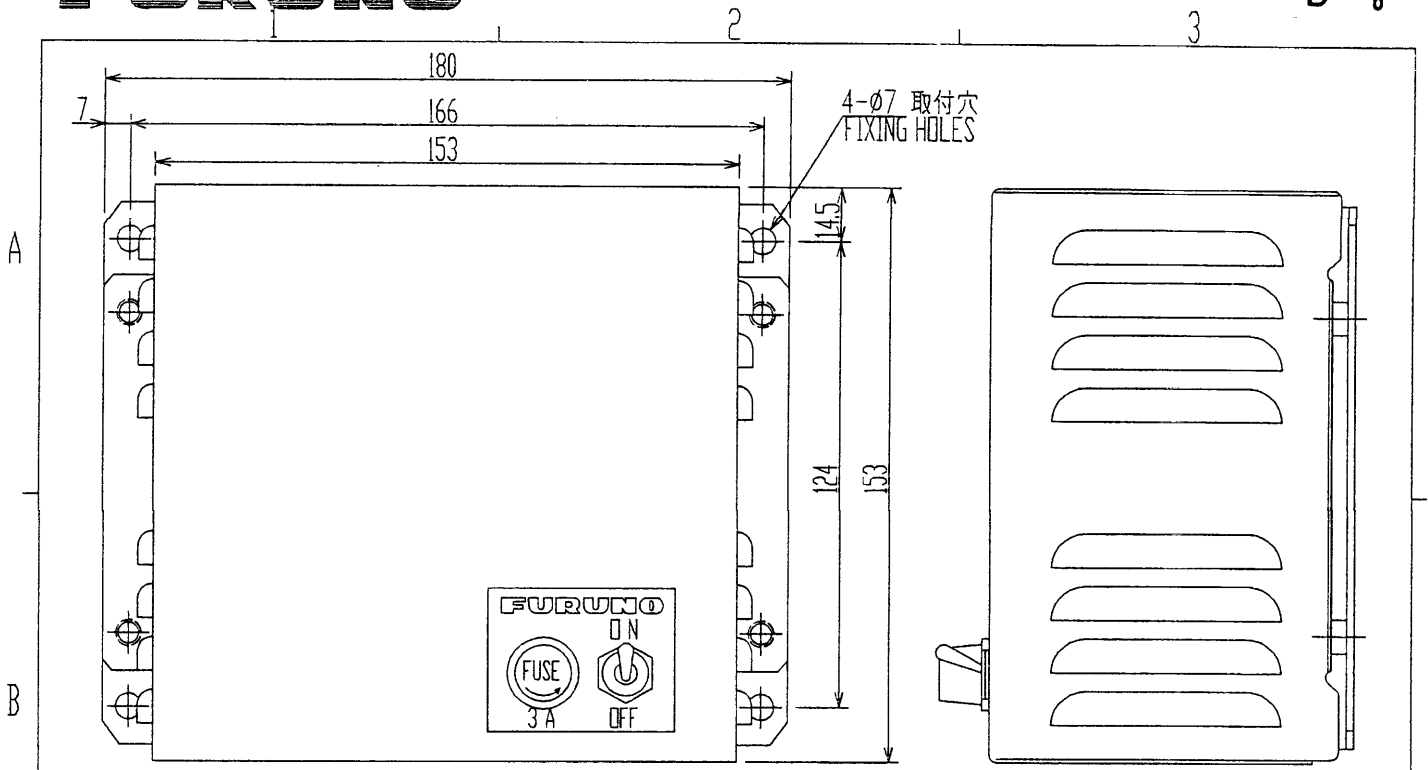
AC INPUT

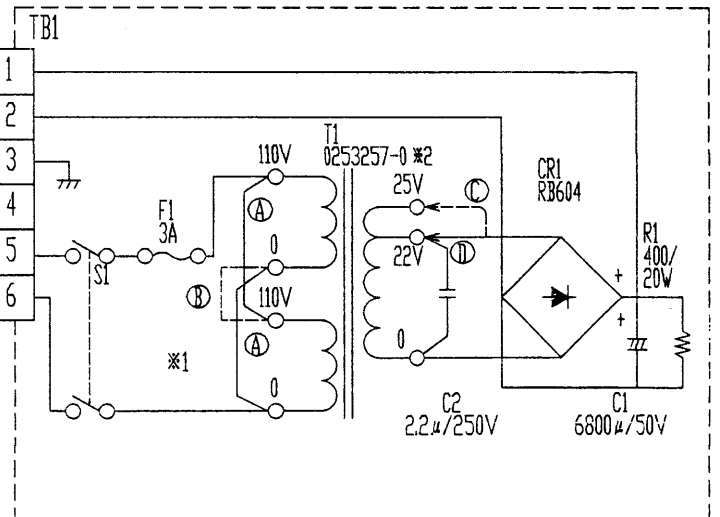

入力電圧に応じて接続を変更して下さい。  
CHANGE TAP CONNECTIONS DEPENDING ON SUPPLY VOLTAGE.

	AC100V	AC110/ 115V	AC220V	AC230V
※1	(A)	(A)	(B)	(B)
※2	(C)	(D)	(D)	(D)

DRAWN Sep. 14 '01 T.YAMASAKI	TITLE PR-62
CHECKED S. YAMASAKI	名称 整流器
APPROVED S. YAMASAKI	外寸図
SCALE 1/2 MASS 3 ±10% kg	NAME RECTIFIER
DWG.No. C5003-034-E	OUTLINE DRAWING

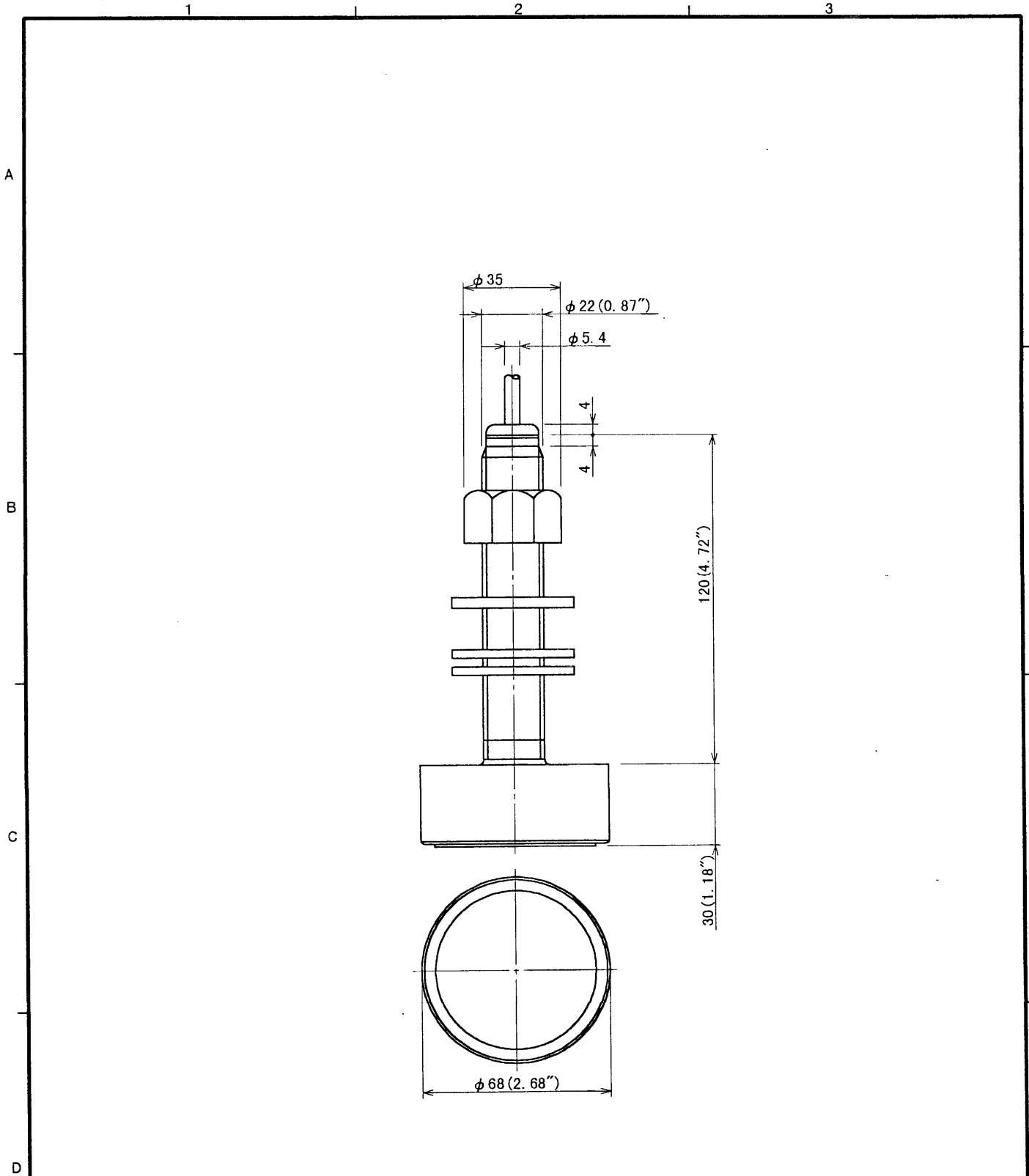

型式	TYPE	コネクタ	PLUG
520-5PSC		8P	
520-5PSD		10P	

DRAWN <i>July 4 '00 T. YAMASAKI</i>		TITLE 520-5PSC/5PSD	
CHECKED <i>July 5 '00 Y. Kuroki</i>		名称 送受波器	
APPROVED <i>July 5 '00 Y. Kuroki</i>		外寸図	
SCALE 1/2	MASS 3.4 kg	質量はケーブル重さを含まず MASS W/O CABLE	NAME TRANSDUCER
DWG. No. C2003-G13- C		OUTLINE DRAWING	

A

B

C

D

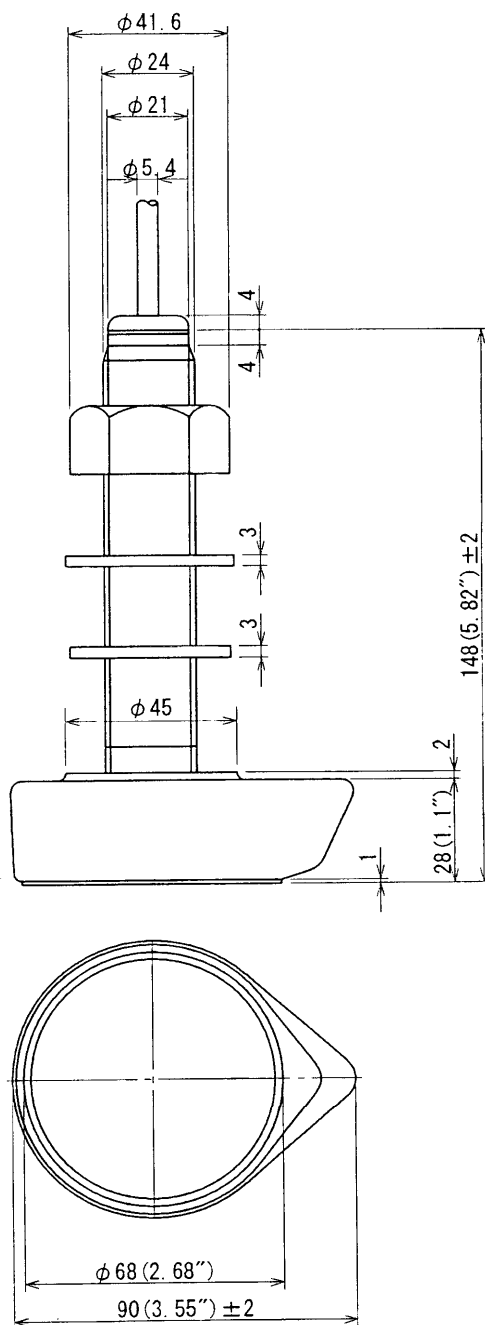

型式 TYPE	コネクタ PLUG
520-5MSC	8P
520-5MSD	10P

DRAWN Nov 27 '00 T. YAMASAKI		TITLE 520-5MSC/5MSD
CHECKED Nov 28 '00 T. K.		名称 送受波器
APPROVED Nov 28 '00 T. K.		外寸図
SCALE 1/2	MASS $\pm 10\%$ 3.5 kg	NAME TRANSDUCER
DWG. No. C2003-G09-E	質量はケーブル重さを含まず。 MASS W/O CABLE.	OUTLINE DRAWING



表 1 TABLE 1

寸法区分 (mm) DIMENSION	公差 (mm) TOLERANCE
$0 < L \leq 50$	$\pm 1.5$
$50 < L \leq 100$	$\pm 2.5$
$100 < L \leq 500$	$\pm 3$

型式 TYPE	コネクタ PLUG
520-5WC	8P
520-5PWD	10P

DRAWN <i>July 4 '00 T. KAWASAKI</i>	TITLE 520-5PWD/5PWC
CHECKED <i>July 5 '00 Y. KAWA</i>	名称 送受波器
APPROVED <i>July 5 '00 Y. KAWA</i>	外寸図
SCALE 1/2	NAME TRANSDUCER
MASS ±10% kg	OUTLINE DRAWING
DWG. No. C2003-G18-B	

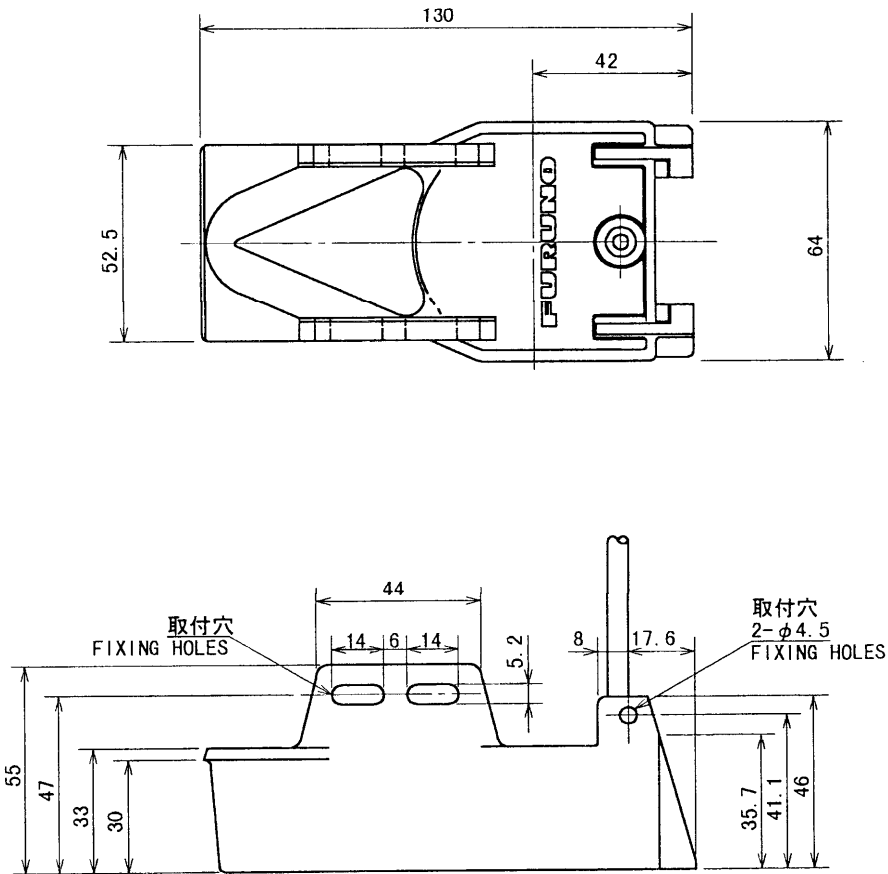
表1 TABLE 1

寸法区分(mm) DIMENSION	公差(mm) TOLERANCE
0 < L ≤ 50	±1.5
50 < L ≤ 100	±2.5

A

B

C

D

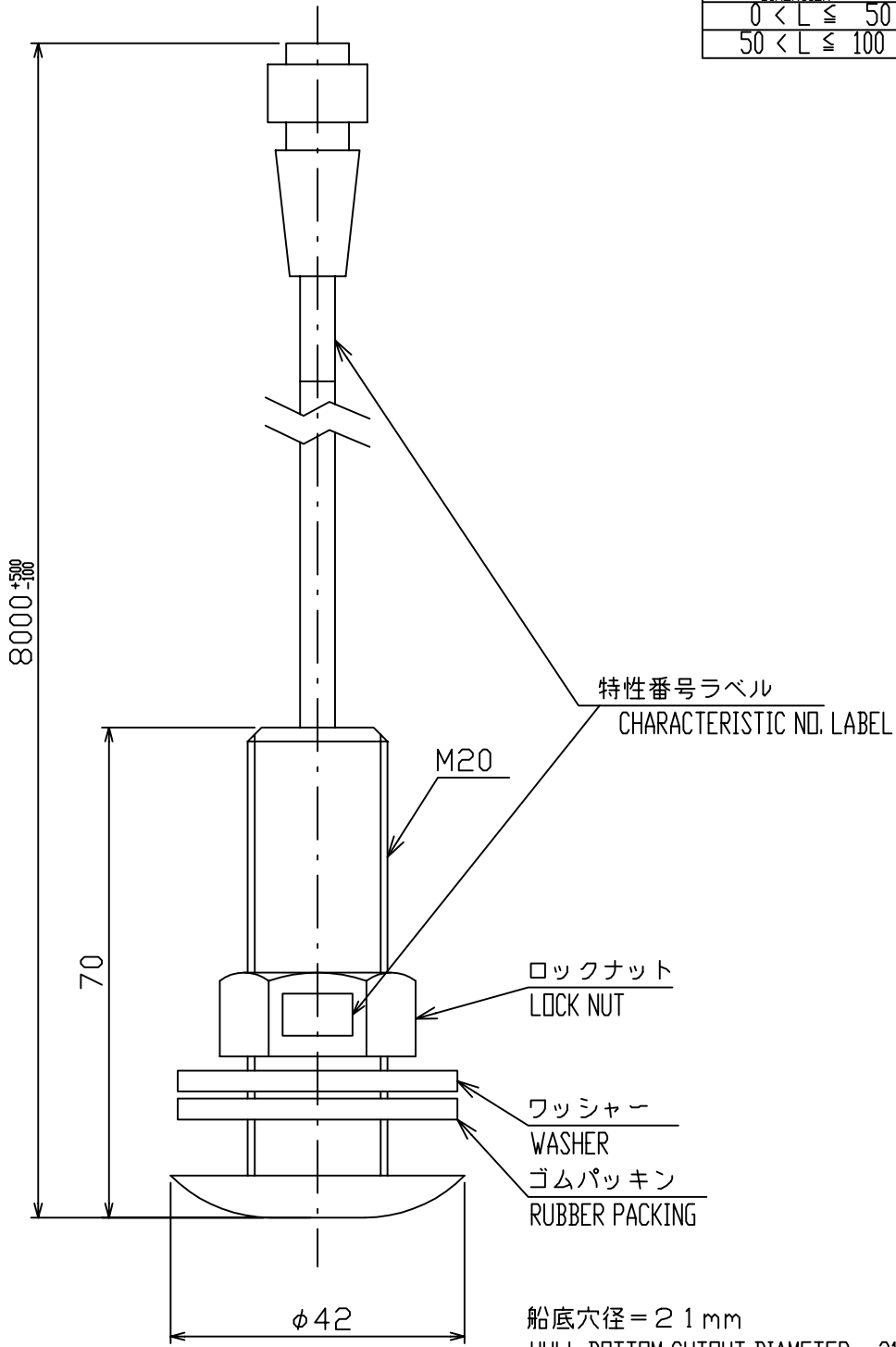

注記

1) 指定なき寸法公差は表1による。

NOTE

1. TABLE 1 INDICATES TOLERANCE OF DIMENSIONS.

DRAWN Nov. 14 '02 T.YAMASAKI		TITLE T-02MSB
CHECKED Nov. 14 '02 Y.KIMURA		名称 水温センサー
APPROVED Nov. 14, '02 <i>Y. Kimura</i>	T-2000	外寸図
SCALE 1/1	MASS 0.5 ±10% kg	NAME THERMO SENSOR
DWG.No. C4322-007-C		OUTLINE DRAWING

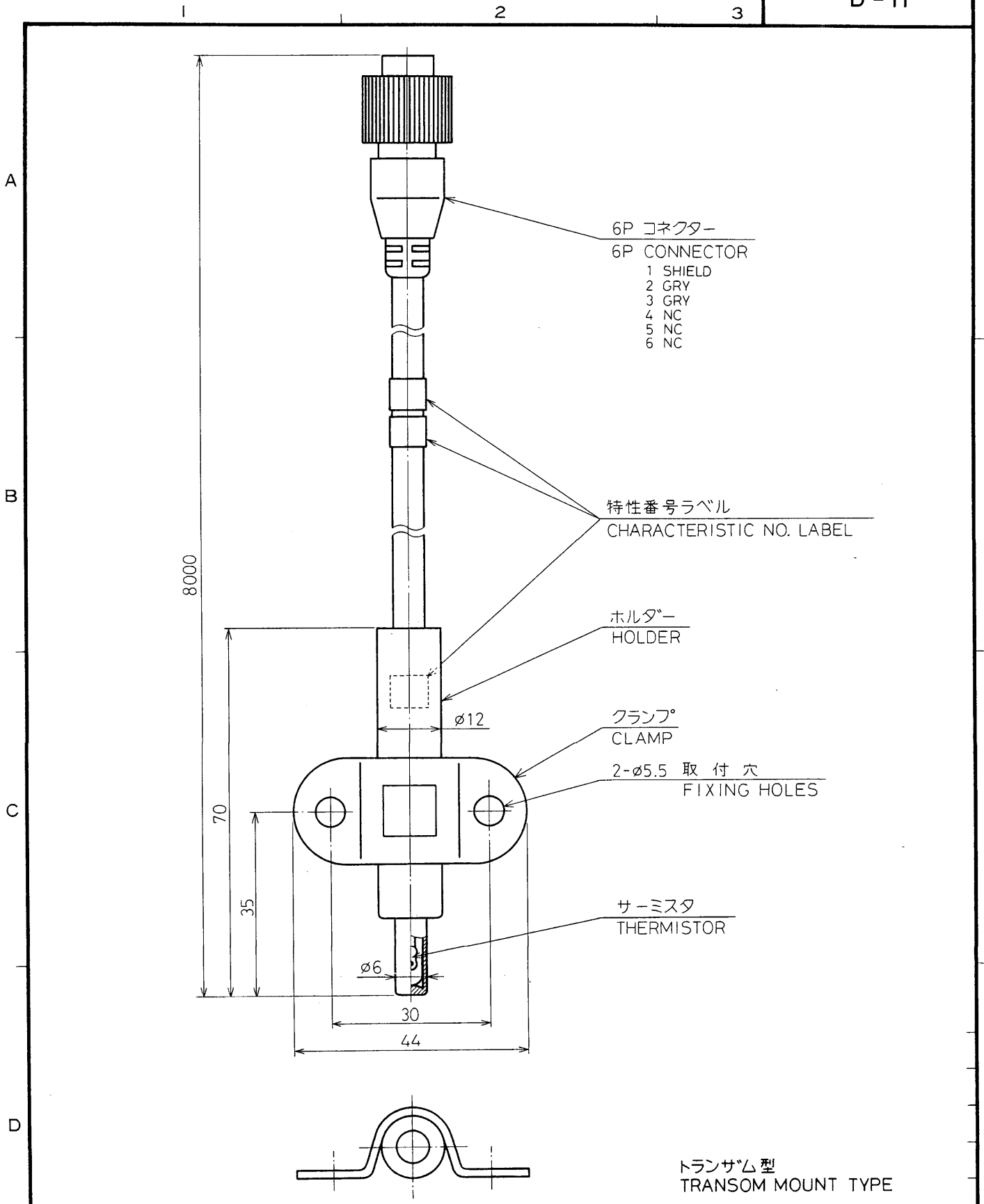

承認 APPROVED	品番 ITEM	品名 NAME	材質 MATERIAL	数量 Q'TY	図番 DWG.NO.	摘要 REMARKS
Feb. 28. 89 T. NAKANO		三角法 THIRD ANGLE PROJECTION				名称 TITLE T-02MTB 水温センサー TEMPERATURE SENSOR
Feb. 28. 89 T. KODAI		尺度 SCALE		1/1		
Feb. 28. 89 T. MIYOSHI		質量 MASS	kg		図番 DWG.NO. C2317-G01-B	

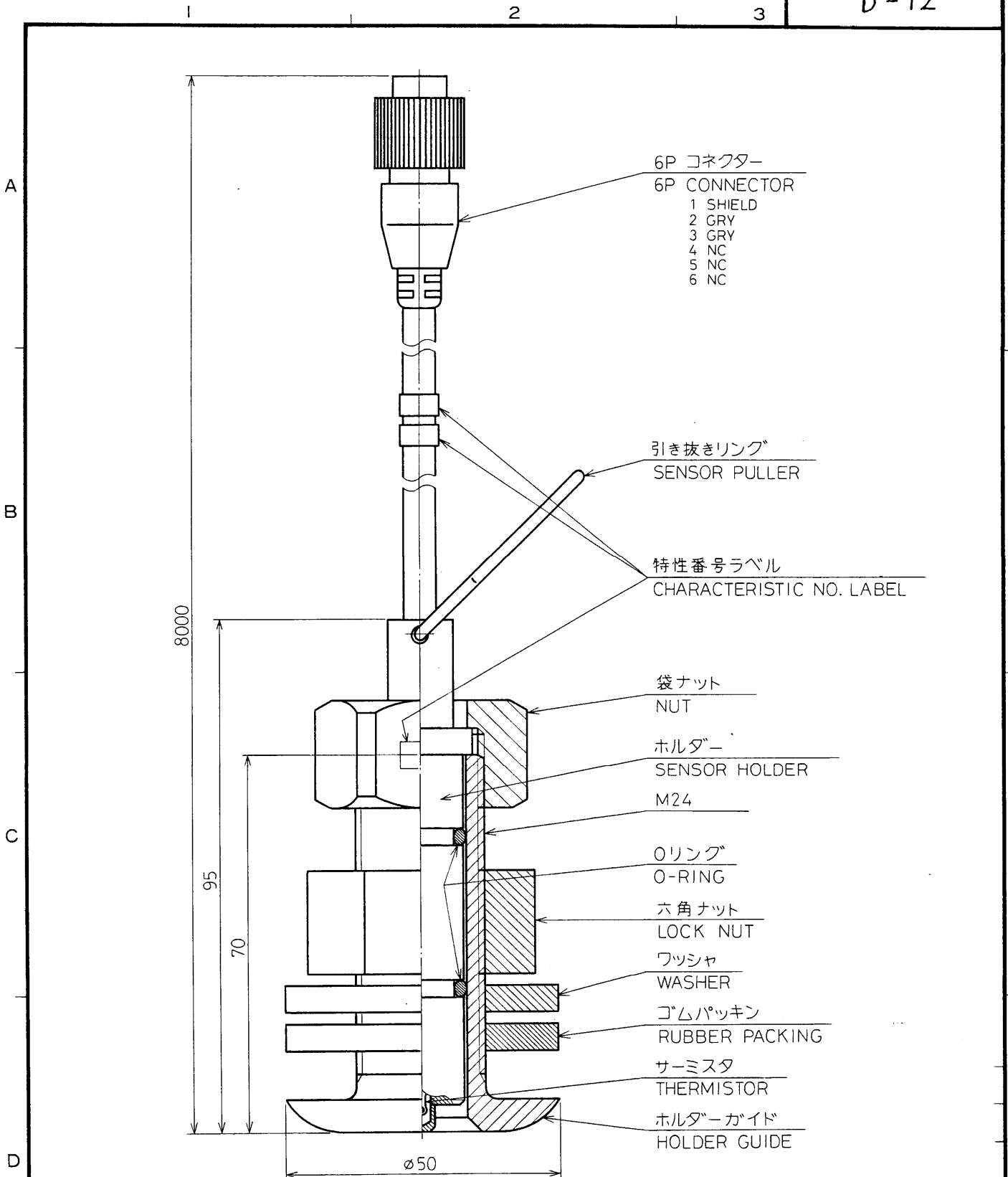

船底貫通型 (取り外し可能)  
THRU HULL MOUNT

品番 ITEM	品名 NAME	材質 MATERIAL	数量 Q'TY	図番 DWG. NO.	摘要 REMARKS
承認 APPROVED	FEB. 28 '89 T. NAKANO	三角法 THIRD ANGLE PROJECTION	名称 TITLE	T-03MSB 水温センサー TEMPERATURE SENSOR	
検図 CHECKED	Feb. 28 '89 T. KODA	尺度 SCALE	1/1		
製図 DRAWN	Feb. 28 '89 T. MIYOSHI	質量 MASS	kg	図番 DWG. NO.	C2317-G02-B

4

3

2

A

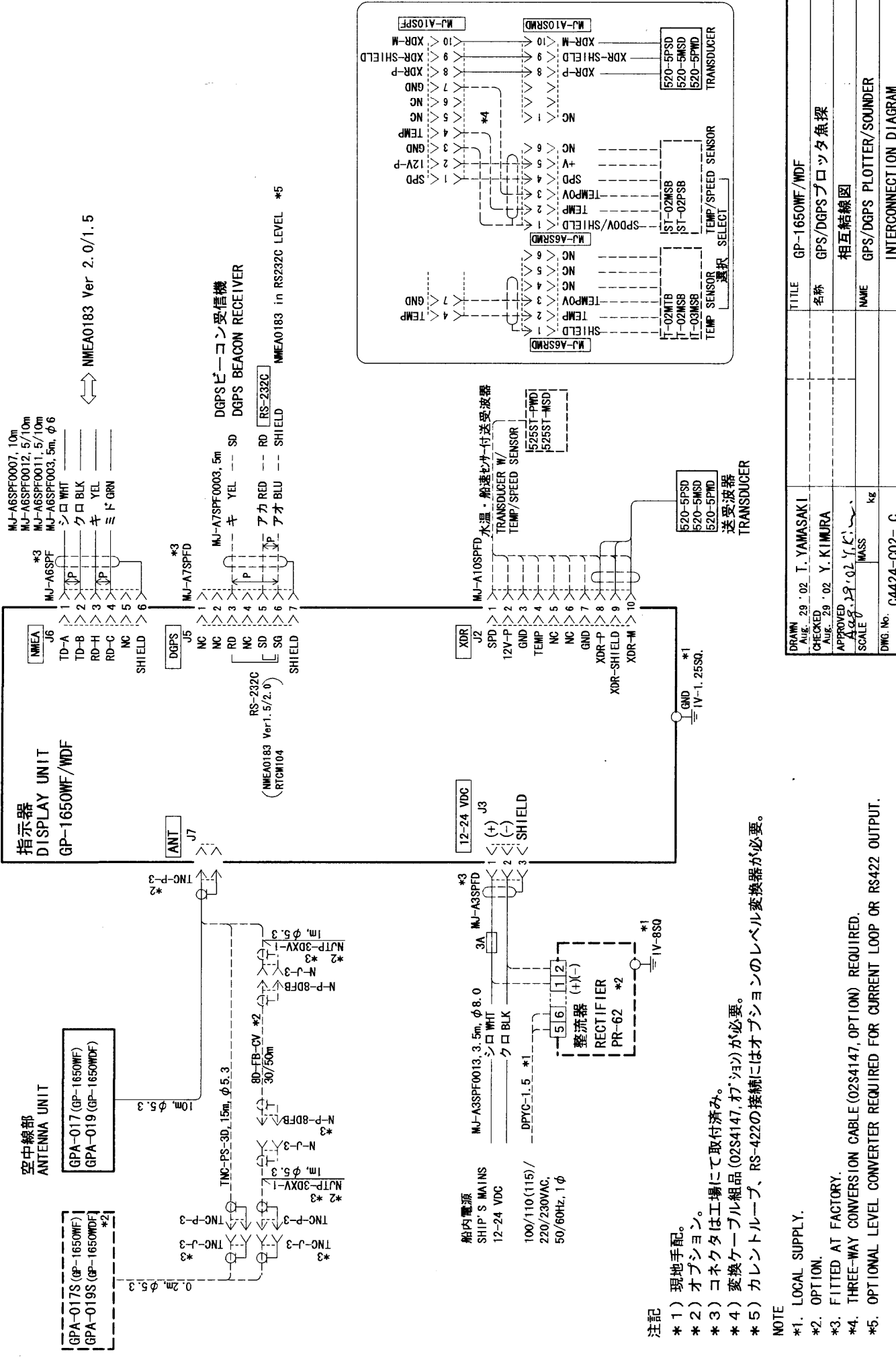

DRAWN Aug. 29 '02 T. YAMASAKI	TITLE GP-1650WF/WDF
CHECKED Aug. 29 '02 Y. KIMURA	名称 GPS/DGPSプロッタ魚探
APPROVED AUG 29 '02 Y.K.	相互結線図
SCALE 1/100	NAME GPS/DGPS PLOTTER/SOUNDER
DWG. No. 04424-C02-C	INTERCONNECTION DIAGRAM

注記  
 \*1) 現地手配。  
 \*2) オプション。  
 \*3) コネクタは工場にて取付済み。  
 \*4) 変換ケーブル組品(02S4147, オプション)が必要。  
 \*5) カレントループ、RS-422の接続にはオプションのレベル変換器が必要。

NOTE  
 \*1. LOCAL SUPPLY.  
 \*2. OPTION.  
 \*3. FITTED AT FACTORY.  
 \*4. THREE-WAY CONVERSION CABLE (02S4147, OPTION) REQUIRED.  
 \*5. OPTIONAL LEVEL CONVERTER REQUIRED FOR CURRENT LOOP OR RS422 OUTPUT.