

INSTALLATION MANUAL

*FURUNO FINLAND
ICE RADAR FICE-100*

*FURUNO FINLAND
OIL RADAR FOIL-200*

Contents

1. SPECIFICATIONS	4
2. CABLING AND CONNECTORS	5
2.1 Connectors on EC-3000 processor	5
2.2 Sensor Data Input.....	6
2.2.1. Introduction.....	6
2.2.2 Serial Interface sensor information.....	6
2.2.3 LAN Interface for sensor information	7
2.3 Connectors on ScanStreamer	8
2.3.1 Introduction.....	8
2.3.2 ScanStreamer DNP2012001	8
2.3.2 ScanStreamer DNP2016009	10
2.4 Connector on RPU-013 of FAR-2xx7	11
2.4 Connector on RPU-024 of FAR-15x8.....	11
2.5 Connectors on up-mast unit of FAR-2xx8/FAR-3000.....	12
3. CONFIGURATION OF DISPLAY RESOLUTION.....	13
4. CONFIGURATION OF PARAMETERS	15
4.1 Vessel dimensions and antenna offsets.....	15
5. ADJUSTMENT OF VIDEO LEVEL	16
5.1 Video level and ADC Gain	16
5.2 How to activate radar video adjustment mode.....	17
5.3 How to adjust video level offset	18
5.4 How to adjust ADC gain.....	19
5.5 How to adjust Trigger delay.....	20
5.6 How to quit radar video adjustment mode	20
6. PERFORMANCE TEST FOR NAVIGATION RADAR	21
6.1 FAR-2xx7	21
6.2 FAR-3000.....	21
7. TROUBLESHOOTING.....	22
7.1. No data from serial data sensors	22
8. INTERCONNECTION DIAGRAM.....	23

Version E, 07 JUN 2019

1. SPECIFICATIONS

Interconnection diagram:

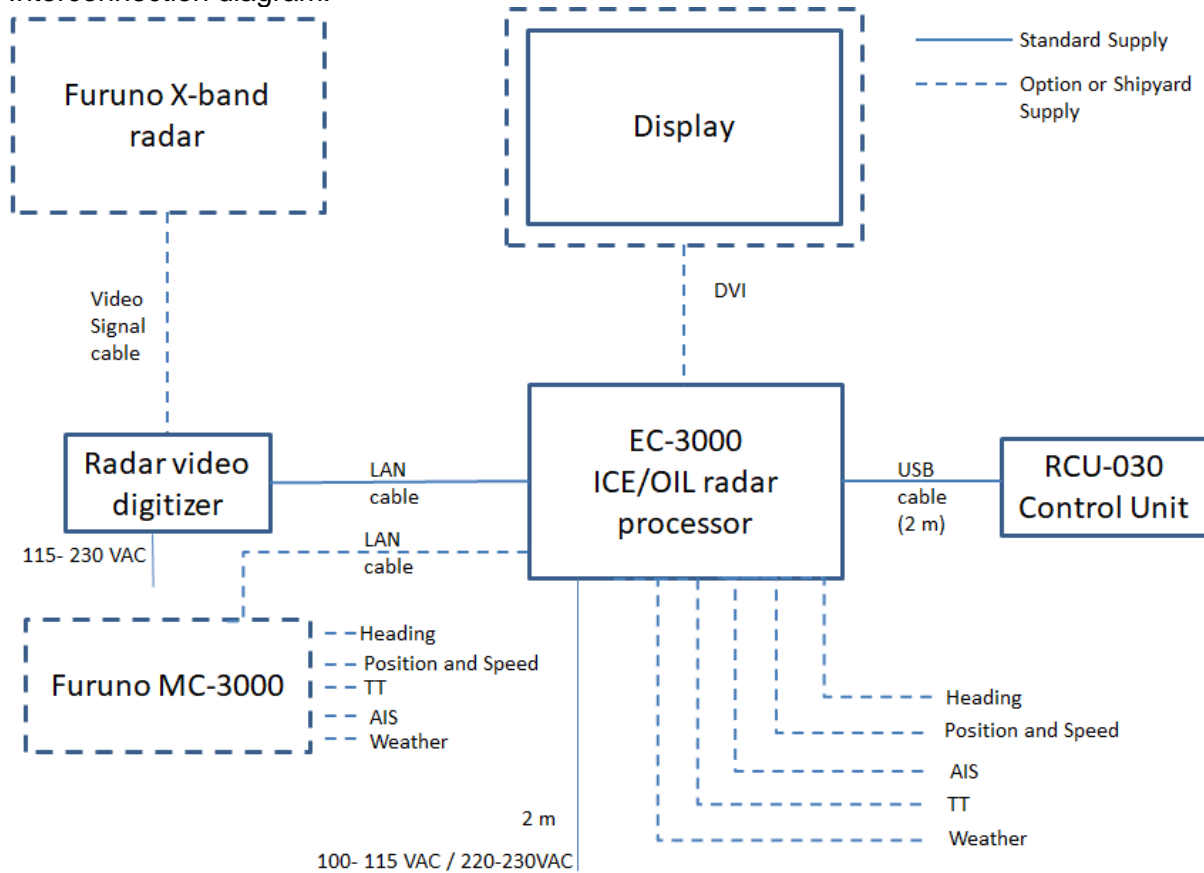

List of Equipment (Standard):

Name	Type	Qty
Ice/Oil Radar processor unit	EC-3000	1
	Power cable	2 m
Control Panel	RCU-030	1
	USB cable	2 m
Radar video digitizer	ScanStreamer DNP2012001 or ScanStreamer MK II	1
	Power cable	2.5 m

List of Equipment (Optional):

Name	Type	Qty
Signal cable (for FAR-2xx7)	FICE-110	10 m
Signal cable (for FAR-3000)	FICE-110	15/30/40/50 m

Input signals	
	Radar signals FAR-2xx7/2xx8/15x8/3000 X-band *)
	- radar video and trigger
	- azimuth and heading line signals
	Heading, position, speed, AIS target and Tracked Target (HDT, THS, GLL, GGA, VTG, VBW, VHW, TTM, VDM, MTW)

*) Minimum requirements for radar signals: Transceiver 12 kW, Antenna radiator 4 ft, Gear box 24 rpm

2. CABLING AND CONNECTORS

2.1 Connectors on EC-3000 processor

Below you can find connectors on EC-3000 processor back panel.

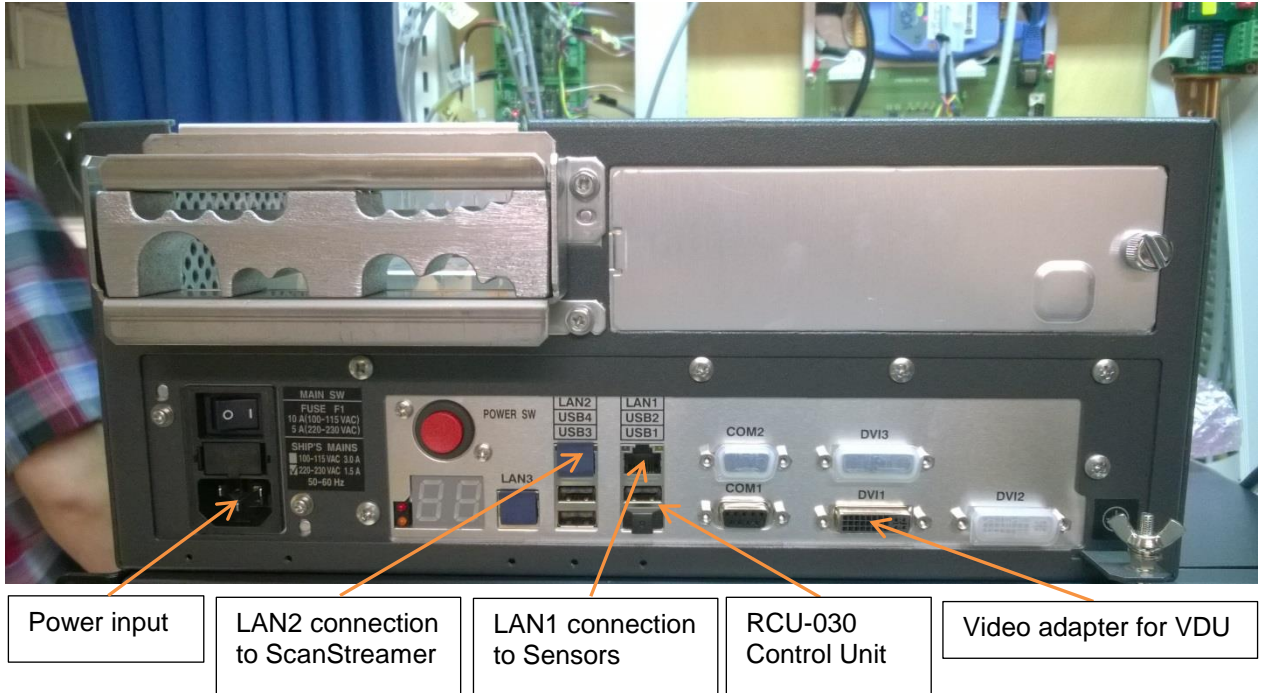

2.2 Sensor Data Input

2.2.1. Introduction

Sensor data can be input either using:

- Serial connector inside EC-3000 (IEC61162-1/2)
- LAN interface from HUB-100 of ECDIS network (IEC61162-450)

Note that target information TT and AIS targets have to be received both either serial interface or LAN interface. Only one interface can be used.

2.2.2 Serial Interface sensor information

Following sentences can be received by FICE-100/FOIL-200:
HDT, THS, GLL, GGA, VTG, ZDA, VBW, VHW, TTM, VDM, MTW

Below you can find connectors for serial line sensor data inside EC-3000 processor. Connector J3 can be used for Gyro signal input (38400 bps). Connectors J5-J6 and J8-J10 can be used for Gyro, EPFS, log and weather data signals (4800 bps). System automatically detects input signals, i.e. there is no need to configure these ports.

Note, that connectors:

- J4 is for VDM, AIS target data (38400 bps)
- J7 is for TTM, Navigation radar tracket targets (4800 bps)

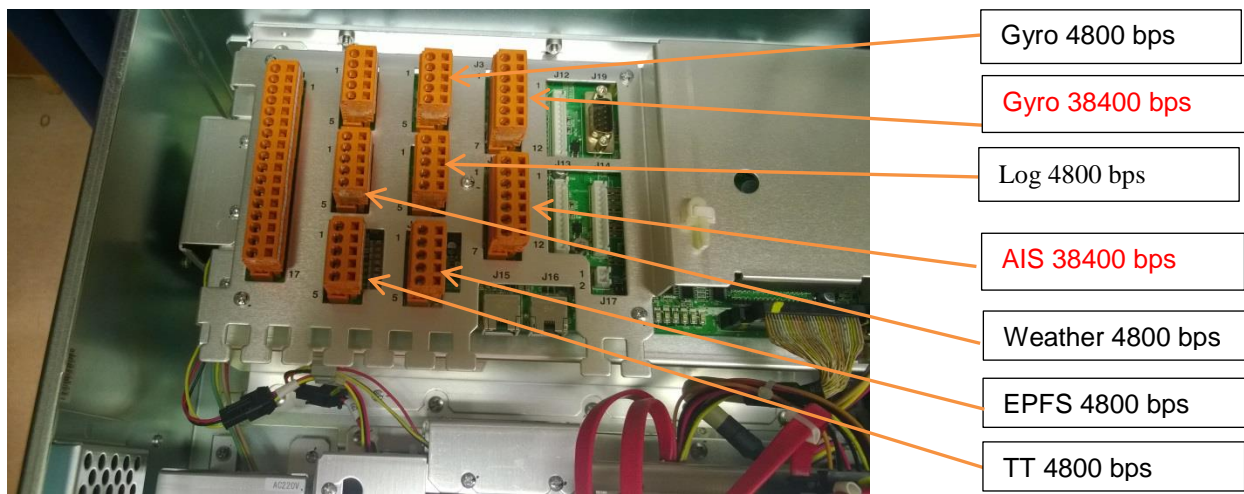

Connectors J3 and J4 are for IEC61162-2

Pin No	Signal	In/Out	Description
1	TDx-A	out	No connection
2	TDx-B	out	No connection
3	RDx-A	in	IEC61162-2
4	RDx-B	in	IEC61162-2
5	ISOGND		Isolation ground
6	RDx-H	in	No connection
7	RDx-C	in	No connection

x= 1, 2

Connectors J5-J10 are for IEC61162-1

Pin No	Signal	In/Out	Description
1	TDx-A	out	No connection
2	TDx-B	out	No connection
3	RDx-H	in	IEC61162-2
4	RDx-C	in	IEC61162-2
5	GND		ground

x= 3, 4, 5, 6, 7, 8

2.2.3 LAN Interface for sensor information

Configuration of sensor receiving from MC-3000/HUB-100 can be done in “sensor.conf” file. You need to configure LAN1 into the same network as MC-3000/HUB-100.

- Open console Press **ALT + X** keys.
- Type **nano sensors.conf** [enter]
- Check that source is as “**source=lwe**”
- Check that own IP address is in the same network space as MC-3000 (for example if MC-3000 IP address is 192.168.1.1) then own IP can be (192.168.1.119).

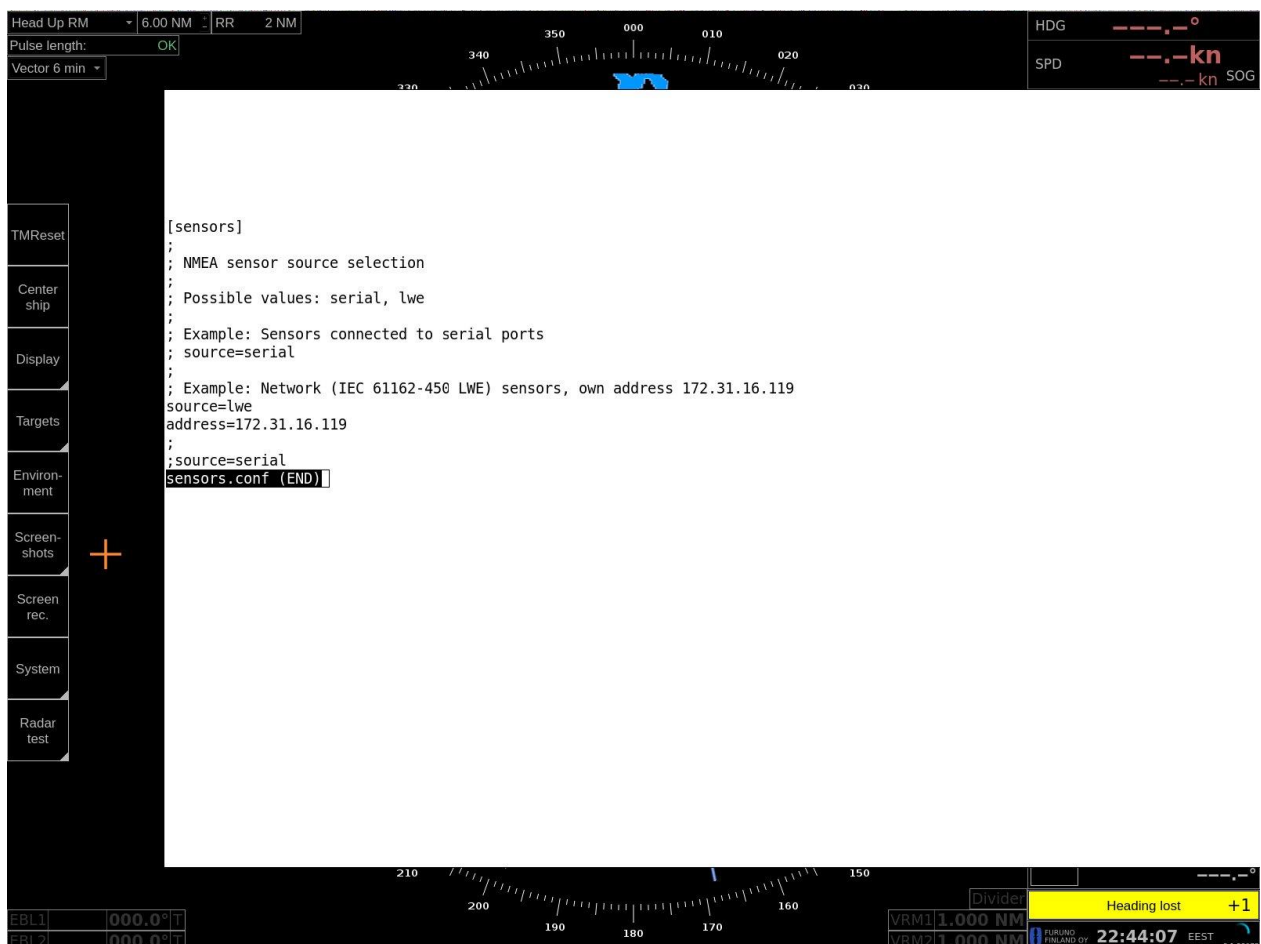

- Save and close editor.

2.3 Connectors on ScanStreamer

2.3.1 Introduction

There are two versions of Scanstreamer available:

- ScanStreamer DNP2012001
- ScanStreamer DNP2016009
- Check which one you have in your system.

A ScanStreamer receives raw radar video from Furuno navigation radar, FAR-2xx7, FAR-2xx8, FAR-15x8 or FAR-3000. Following information is received from Furuno navigation radar. It digitizes analogue video and send it to EC-3000 through LAN:

- Raw radar video
- Trigger
- Bearing pulse
- Head line

2.3.2 ScanStreamer DNP2012001

Below is shown connectors on DNP2012001:

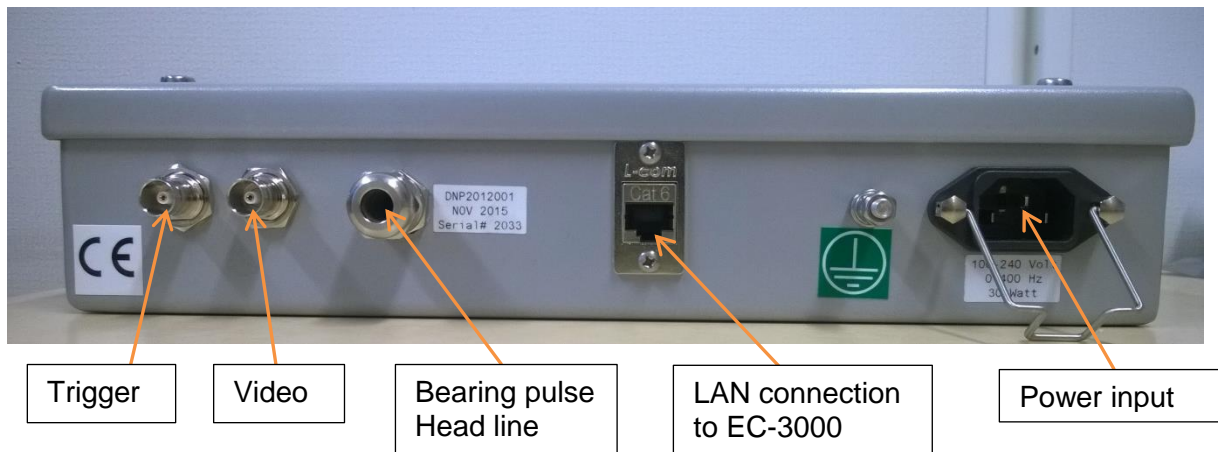

Oil radar/Ice radar (EC-3000) processor receives digitized radar video through LAN connection.

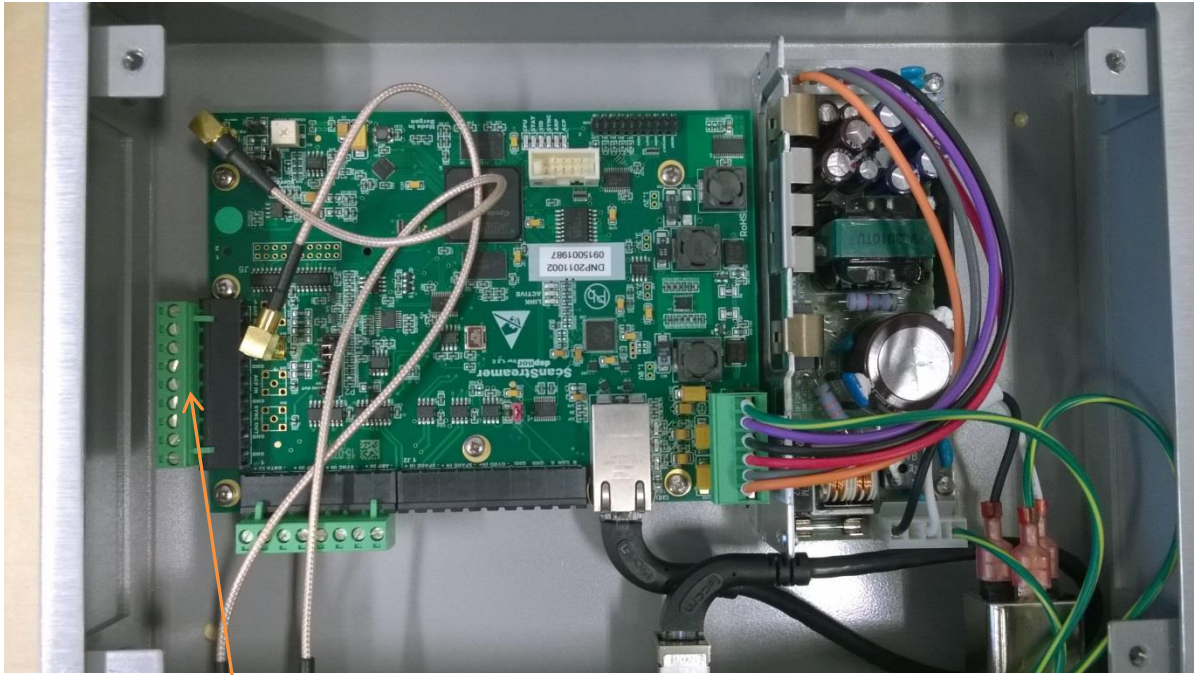

Connector J4
Bearing pulse
Head line

Connector J4

Pin No	Signal	Description
1	ARP IN	Head line
2	GND	ground
3	Sync in	No connection
4	GND	No connection
5	ACP IN	Bearing pulse
6	GND	Ground
7	SYNC OUT	No connection
8	GND	No connection
9	GND	No connection

2.3.2 ScanStreamer DNP2016009

Below is shown connectors on DNP2016009:

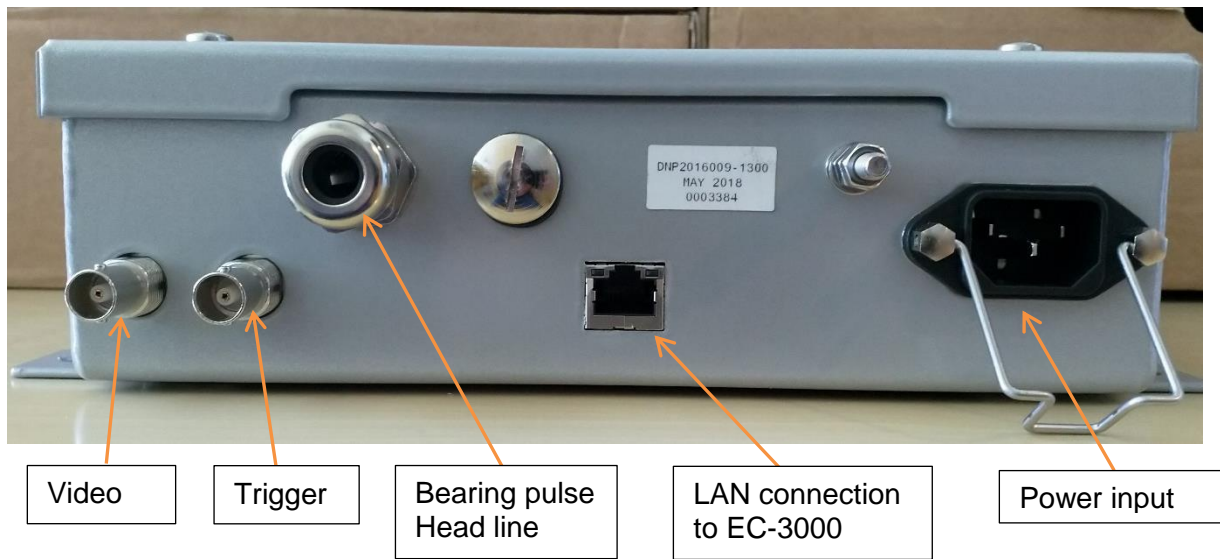

Oil radar/Ice radar (EC-3000) processor receives digitized radar video through LAN connection.

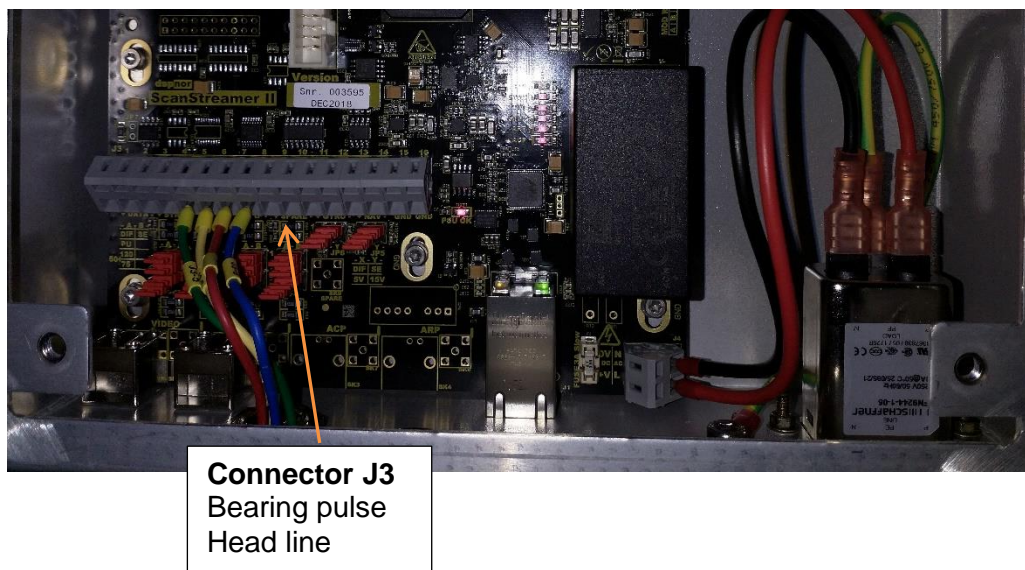

Connector J3
Bearing pulse
Head line

Connector J3

Pin No	Signal	Description
J3-5	ACP IN	Bearing pulse
J3-6	GND	Ground
J3-7	ARP IN	Head line
J3-8	GND	ground

2.4 Connector on RPU-013 of FAR-2xx7

Connect cable to SLAVE 1 connector (J617)

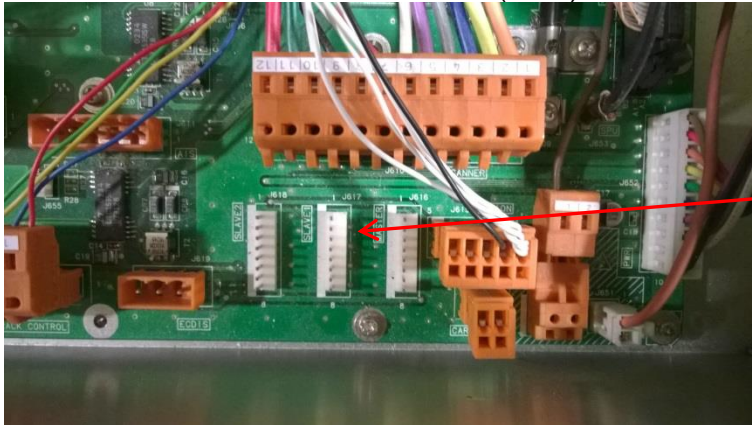

Connect FICE-110 cable to SLAVE 1 connector

2.4 Connector on RPU-024 of FAR-15x8

Connect cable to SLAVE 1 connector (J611)

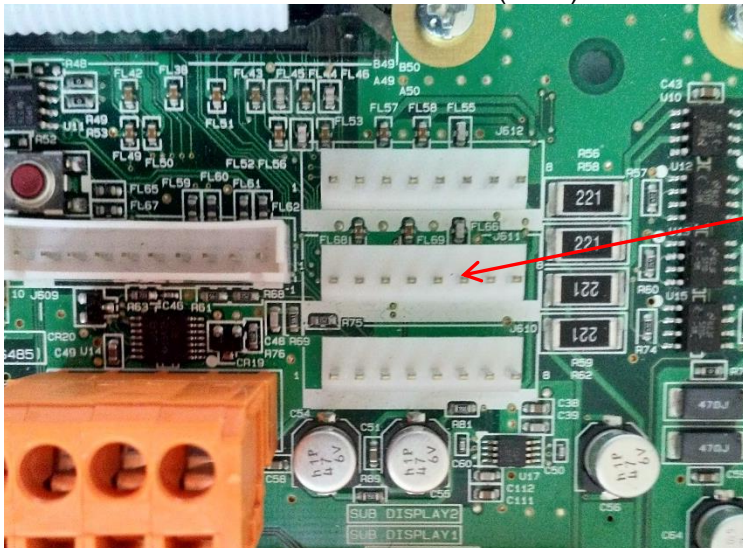

Connect FICE-110 cable to SLAVE 1 connector

2.5 Connectors on up-mast unit of FAR-2xx8/FAR-3000

Connect FICE-110 cable to TB 803 (trigger, bearing pulse and head line) and to TB804 (radar video) as shown below.

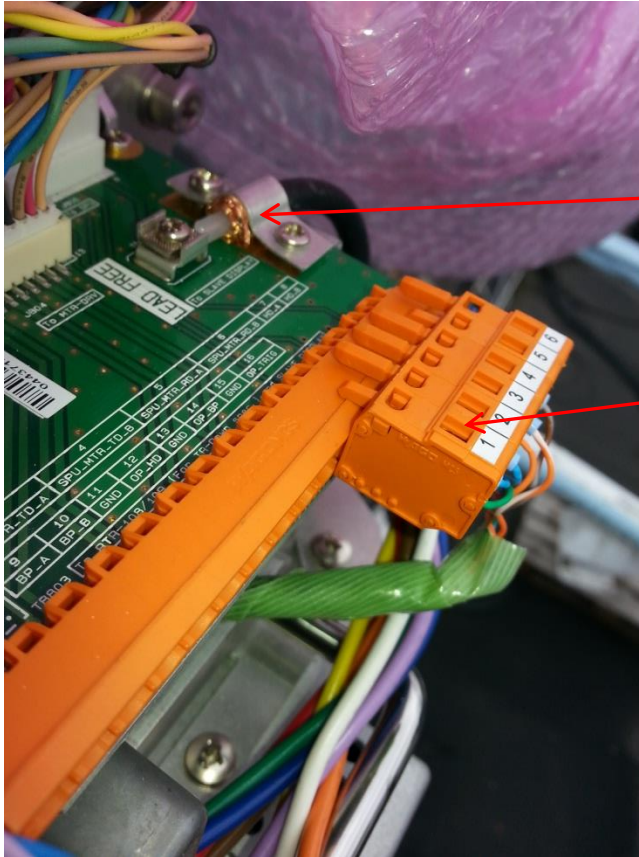

Radar video cable connected to TB 804 connector (TO SLAVE DISPLAY)

WAGO connector connected to TB 803 connector

COAXIAL CABLE: TB804 on RF-TB board

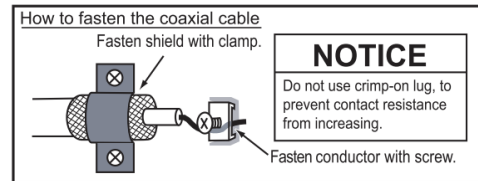

3. CONFIGURATION OF DISPLAY RESOLUTION

When booting up the system it is automatically detecting display connected to system. For some cases system fails to detect correctly connected display and you need to manually enter display resolution and dimensions of monitor.

To configure manually display resolution, precede as follows:

1. During boot up the system you following display will be shown.

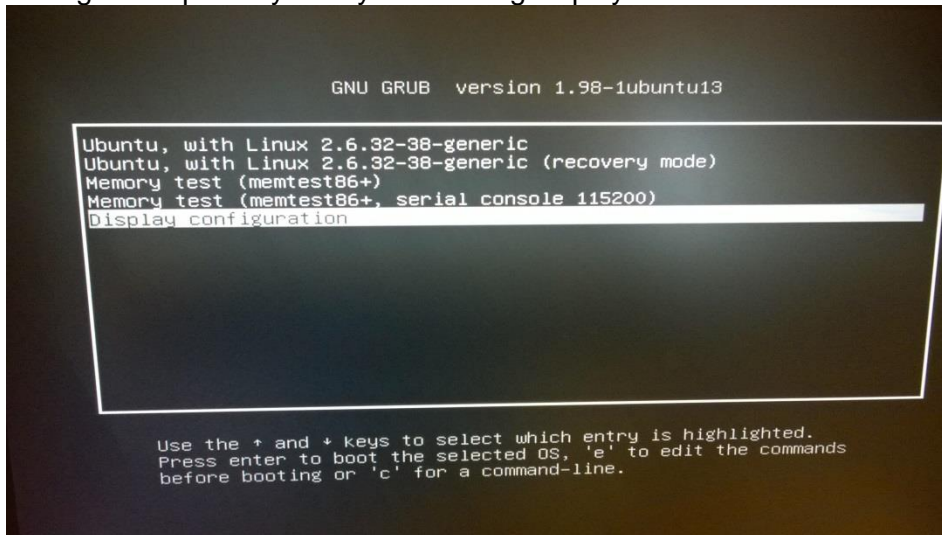

Select Display configuration.

2. Select correct resolution for display

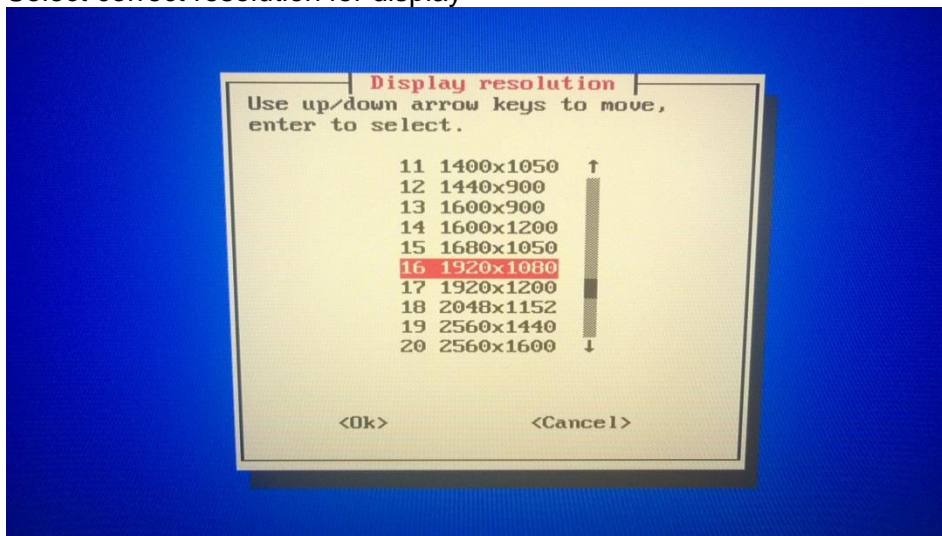

3. Enter width in millimeters

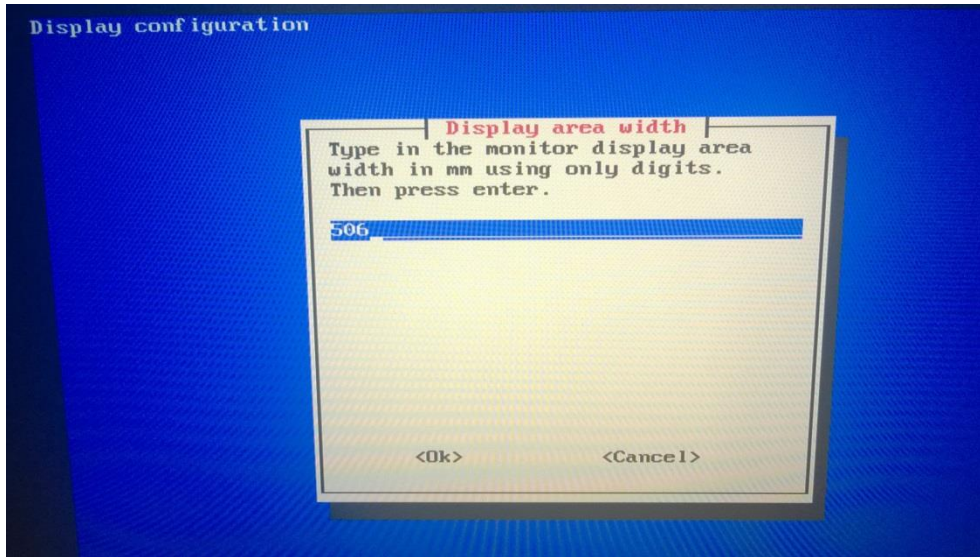

4. Enter height in millimeters

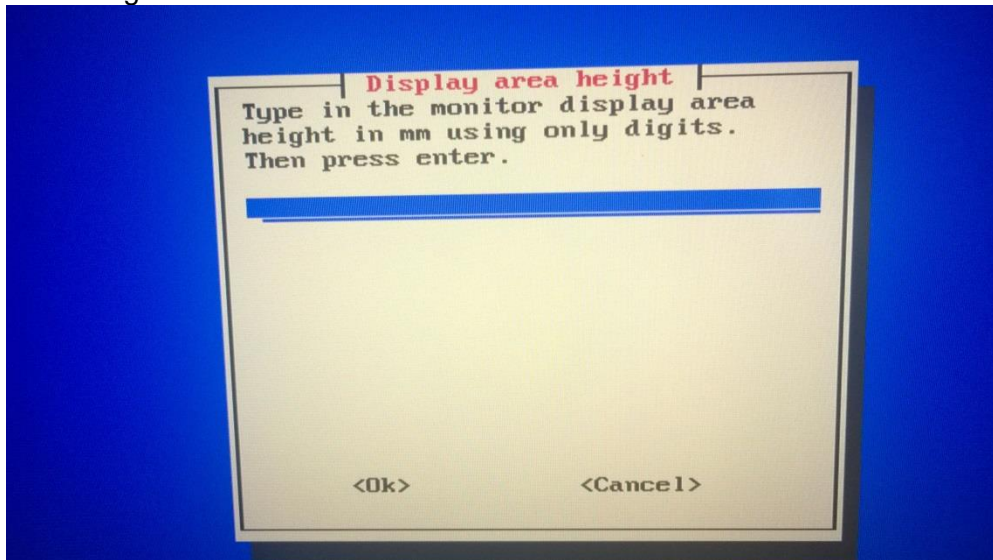

5. Check that you have correct values and confirm by selecting Yes.

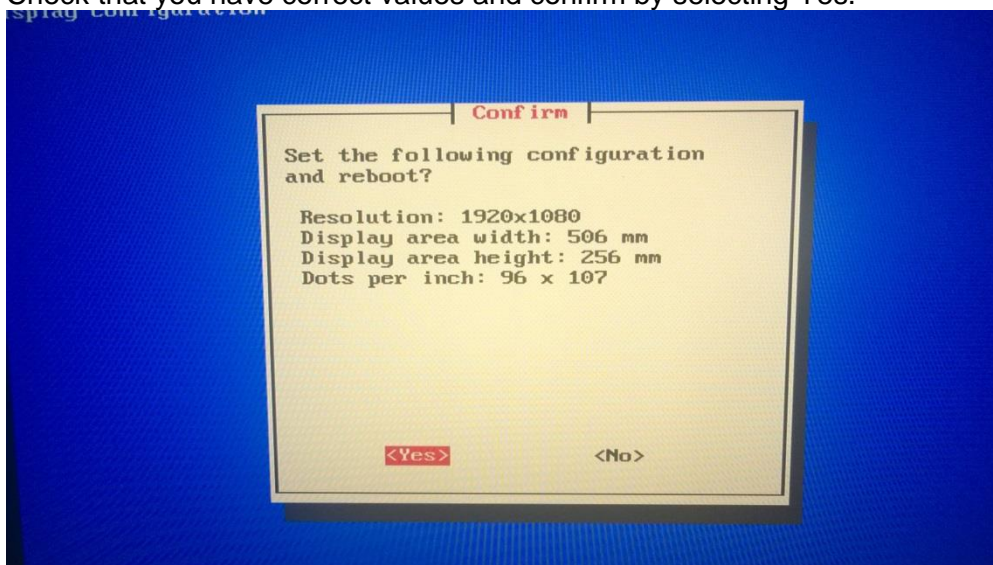

4. CONFIGURATION OF PARAMETERS

4.1 Vessel dimensions and antenna offsets

Sensor and conning positions on ship are in “vessel.config” file, which must be edited at installation time.

No.	Description	Function
1.	Power up Ice/Oil radar	Startup Ice/Oil radar
2.	Open login screen	Press Alt+x to open console
4.	Edit vessel.config file	type: nano vessel.config [enter]
5.	Set length and width	Enter ship measurements (in meters)
6.	Set offsets to CCRP, gps antenna and radar antenna	<p>; Offsets are measured in meters from ship center point</p> <p>; Longitudinal: positive (bow), negative (stern) or zero (center)</p> <p>; Transverse: positive (starboard), negative (port) or zero (center)</p> <p>[ccrp_offset]</p> <p>longitudinal=xx.x transverse=xx.x</p> <p>[radar_offset]</p> <p>; Offset of radar antenna position from ship's center point</p> <p>longitudinal=xx.x transverse=xx.x</p> <p>[gp_offset]</p> <p>; Offset of gps antenna position from ship's center point</p> <p>longitudinal=xx.x transverse=xx.x</p>
7.	Save your edits	Ctrl-X and Y
8.	Restart ice/oil radar	type: sudo reboot

5 ADJUSTMENT OF VIDEO LEVEL

5.1 Video level and ADC Gain

When installation of FICE-100/FOIL-200 is done, you have to check that video level is correctly set. FICE-100/FOIL-200 radar uses raw radar video from navigation radar to make ICE/Oil radar image on FICE-100/FOIL-200 screen. Each navigation radar has a bit different video level in output for FICE-100/FOIL-200. To adopt for different video level you can adjust video level offset and ADC gain (signal amplifier).

Below is typical video signal received from FAR-2xx7 or FAR-3000.

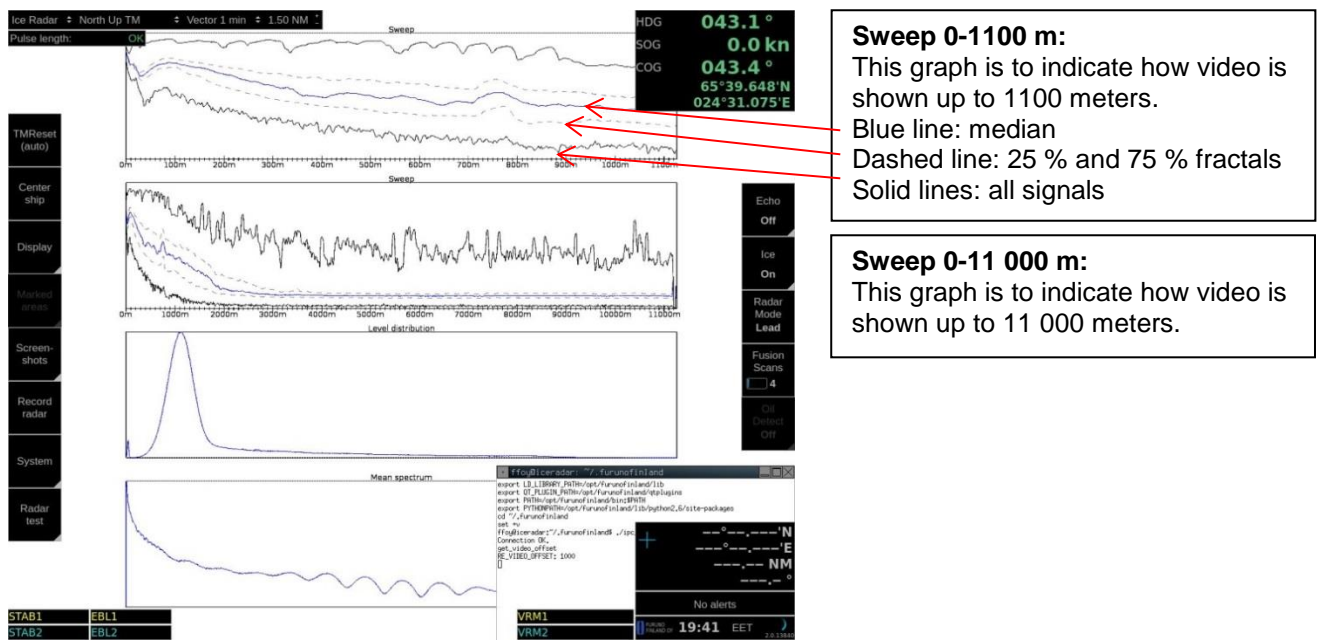

Below is example of incorrect video level offset:

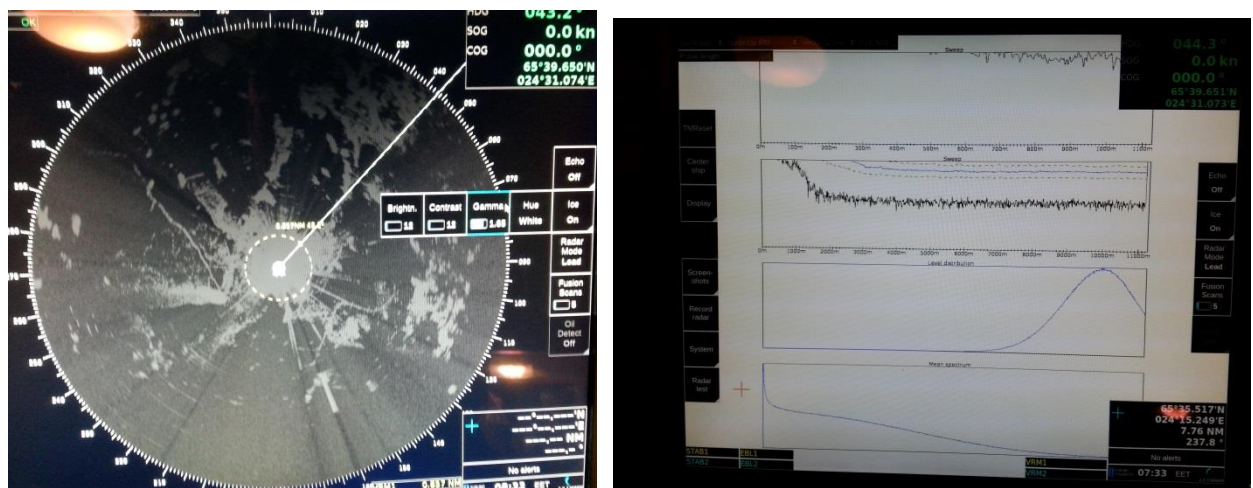

Photos above: Video level is much too high. Near area is not readable at all. You can see it also in scope display.

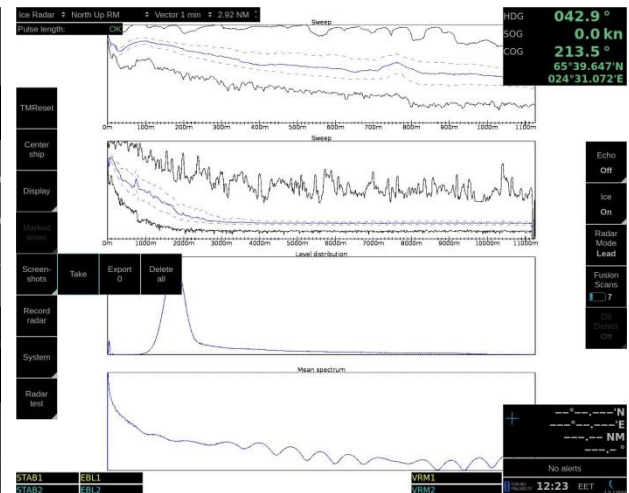
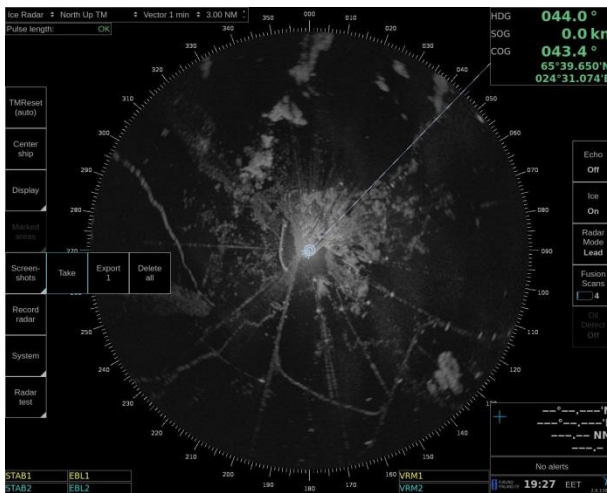

Photos above: Video level offset is adjusted. You can see in scope display that video is readable during antenna sweep in whole range.

5.2 How to activate radar video adjustment mode

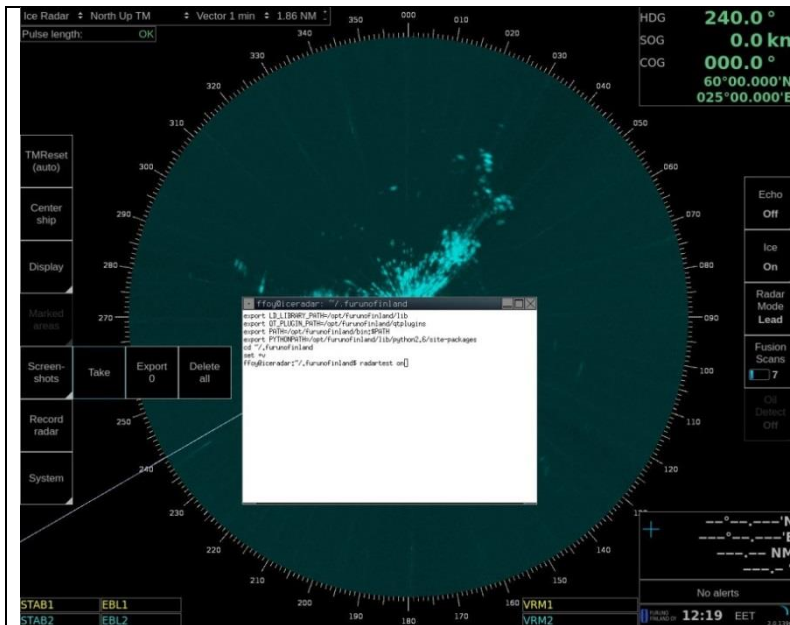

You can activate FICE-100/FOIL-200 video adjustment mode:

1. Click Alt+x keys together to get console on screen.
2. type **“Radartest on”** and click <enter>
3. Radar test button appears on screen left hand side.

5.3 How to adjust video level offset

Adjustment range of Video Offset:
 ScanStreamer DNP2012003: **-1.00 - 1.00**
 ScanStreamer DNP2016001: **0 - 255**

Before video level adjustment:

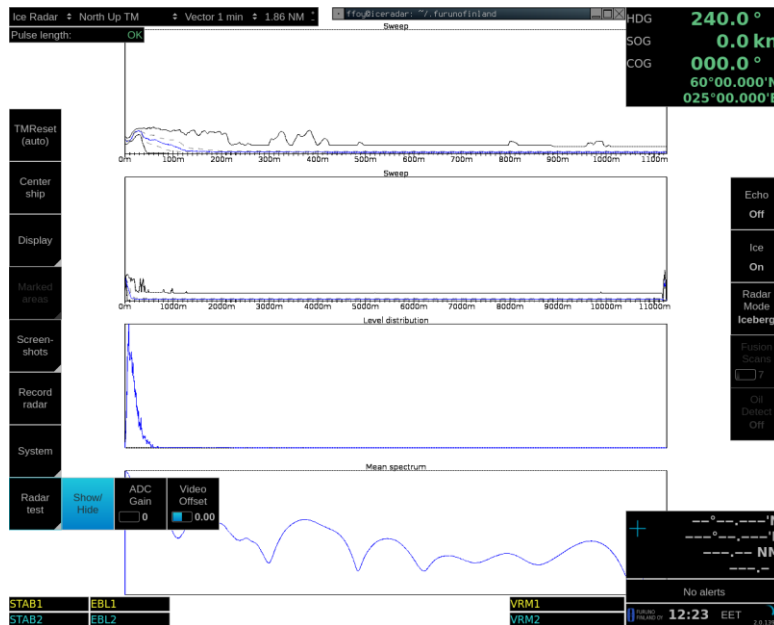

To adjust video level offset:

1. Click **Radar test** button, then click **Show/Hide**.
2. Video signal adjustment window appears, click Radar test button to open menu.
3. Move cursor in Video Offset button and adjust video level by scrolling thumb wheel.
4. Wait a moment to see what effects it caused to video level offset (in sweep graphs)

After adjustment:

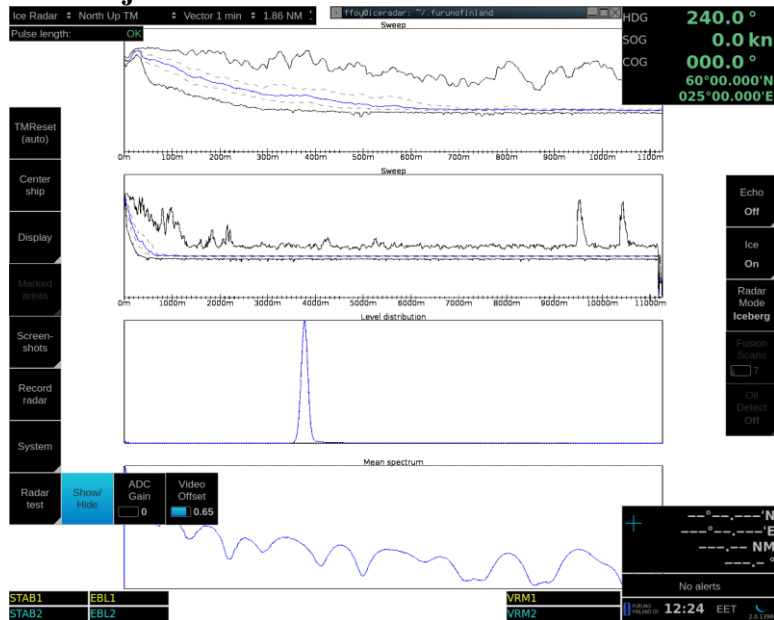

5.4 How to adjust ADC gain

Adjustment range of ADC Gain:

ScanStreamer DNP2012003: **0 - 6**

ScanStreamer DNP2016001: **0 - 255**

Before gain adjustment:

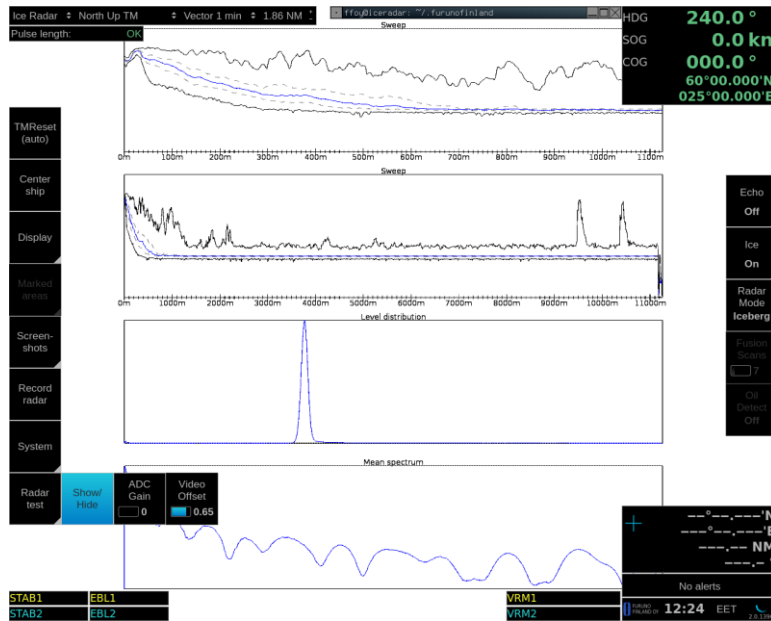

To adjust video level:

1. Click Radar test button to open menu.
2. Move cursor in ADC Gain button and adjust ADC Gain by scrolling thumb wheel.
3. Wait a moment to see what effects it caused to video (in sweep graphs)

After adjustment:

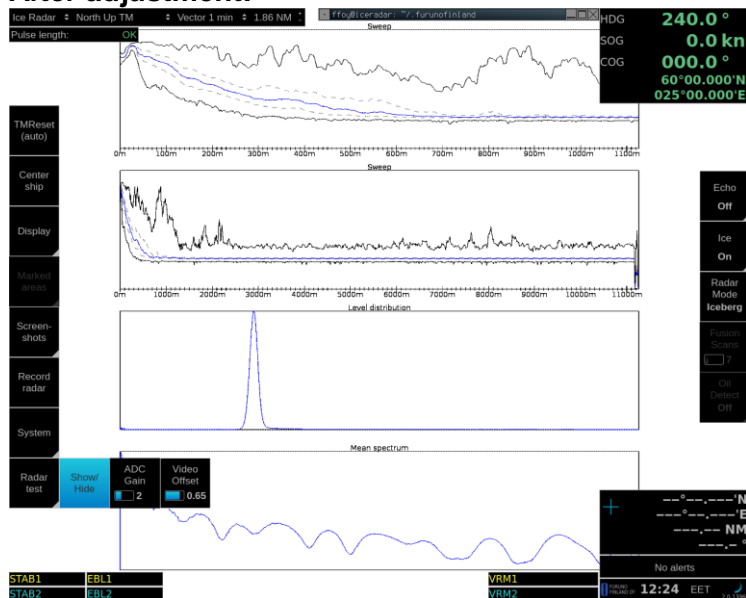

5.5 How to adjust Trigger delay

You may need to adjust trigger delay on FICE-100/FOIL-200. This is very much depending on cable length between navigation radar and ScanStreamer. Measure distance of echo on Navigation radar. Measure the same echo on FICE-100/FOIL-200, if there is difference in distance you can use Trigger delay to adjust echoes on FICE-100/FOIL-200 display.

5.6 How to quit radar video adjustment mode

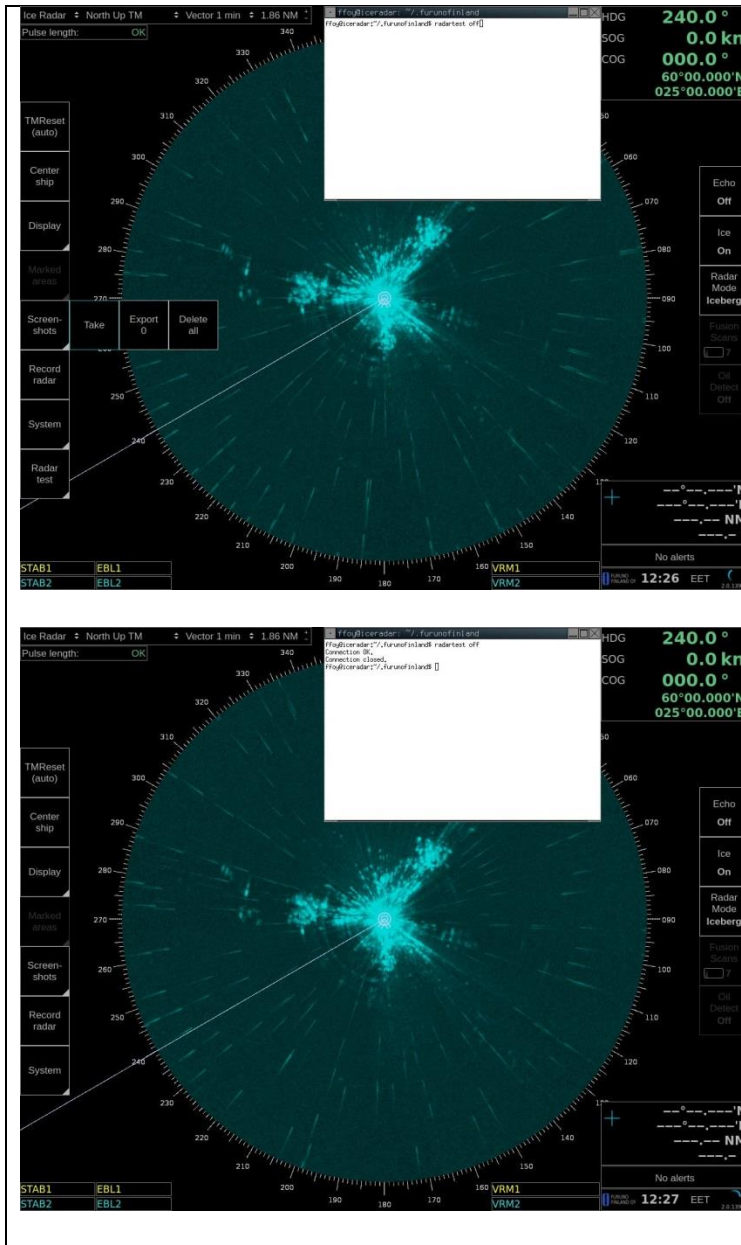

To quit radar video adjustment mode:

1. Open Console, type **radartest off** and press <enter>
2. Radar test button disappears.
3. Close Console.

6. PERFORMANCE TEST FOR NAVIGATION RADAR

6.1 FAR-2xx7

FAR-2xx7 is used as normal navigation radar. To verify performance of radar, see installation manual of FAR-2xx7. Following should be proceeded:

- “Tune initialize”
- Check TX time of magnetron
- Use “Performance monitor” to check gain. Performance monitor is an option. If not available, check TX time of magnetron. Replace magnetron if TX time is more than 5000 hours.

6.2 FAR-3000

Automatic tuning is initialized during the installation. However, if you feel that automatic tuning is not working properly try re-initializing the tuning. Right-click the [TUNE] button then select [Tune Initialize] to start the initialization. The indication [Tune INI] appears during initialization.

7. TROUBLESHOOTING

7.1. No data from serial data sensors

If heading or position is missing, you can do following things:

1. Check that data is sent by the sensor(s).
2. Check that cabling is correctly done and connectors properly fixed.

To check configuration of COM –ports:

A) Sensor traffic

- Click Alt+x together to open console
- Type: **cat /dev/ttyXR2** (ttyXR2 = J3, ttyXR3 = J4, ttyXR4 = J5, ..., ttyXR9 = J10)

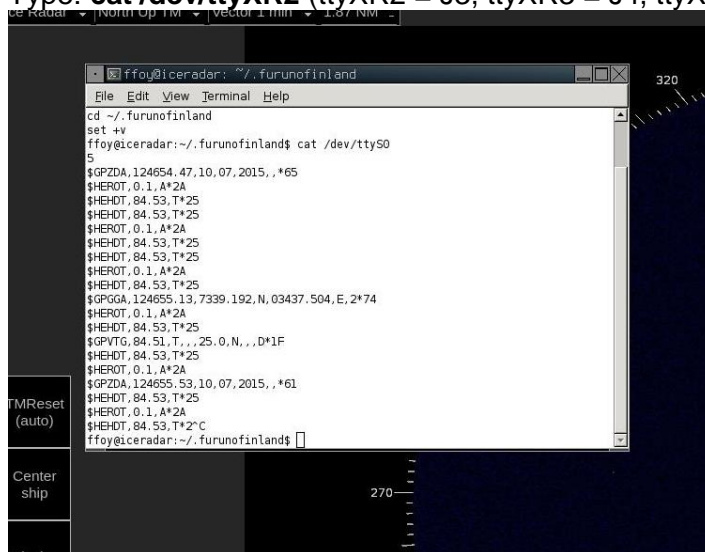

```
ffoy@iceradar: ~/furunofinland
cd ~/furunofinland
set +v
ffoy@iceradar:~/furunofinland$ cat /dev/ttyS0
5
$GPZDA,124654.47,10,07,2015,,*65
$HEROT,0.1,A*2A
$HEHDT,84.53,T*25
$HEHDT,84.53,T*25
$HEROT,0.1,A*2A
$HEHDT,84.53,T*25
$HEHDT,84.53,T*25
$HEROT,0.1,A*2A
$HEHDT,84.53,T*25
$GPGGA,124655.13,7339.192,N,03437.504,E,2*74
$HEROT,0.1,A*2A
$HEHDT,84.53,T*25
$OPVTG,84.51,T,,25.0,N,,D*1F
$HEHDT,84.53,T*25
$HEROT,0.1,A*2A
$GPZDA,124655.53,10,07,2015,,*61
$HEHDT,84.53,T*25
$HEROT,0.1,A*2A
$HEHDT,84.53,T*2C
ffoy@iceradar:~/furunofinland$
```

You should now see sensor traffic on screen. Press Ctrl-C to stop it.

8. INTERCONNECTION DIAGRAM

