

FURUNO

INSTRUMENT

WIND ANGLE	Model FI-501
CLOSE HAULED WIND ANGLE	Model FI-502
COURSE PILOT	Model FI-505
RUDDER	Model FI-506



FURUNO ELECTRIC CO., LTD.

www.furuno.com



ECF
(Elemental Chlorine Free)

The paper used in this manual
is elemental chlorine free.

FURUNO ELECTRIC CO., LTD.

9-52, Ashihara-cho,
Nishinomiya, 662-8580, JAPAN

•FURUNO Authorized Distributor/Dealer

All rights reserved.

Printed in Japan

A : OCT. 2007
E : OCT. 31, 2012

Pub. No. OME-72660-E
(REFU) FI-501/502/505/506



* 00016698214 *

IMPORTANT NOTICES

General

- This manual has been authored with simplified grammar, to meet the needs of international users.
- The operator of this equipment must read and follow the descriptions in this manual. Wrong operation or maintenance can cancel the warranty or cause injury.
- Do not copy any part of this manual without written permission from FURUNO.
- If this manual is lost or worn, contact your dealer about replacement.
- The contents of this manual and equipment specifications can change without notice.
- The example screens (or illustrations) shown in this manual can be different from the screens you see on your display. The screens you see depend on your system configuration and equipment settings.
- Save this manual for future reference.
- Any modification of the equipment (including software) by persons not authorized by FURUNO will cancel the warranty.
- All brand and product names are trademarks, registered trademarks or service marks of their respective holders.

How to discard this product

Discard this product according to local regulations for the disposal of industrial waste. For disposal in the USA, see the homepage of the Electronics Industries Alliance (<http://www.eiae.org/>) for the correct method of disposal.

How to discard a used battery

Some FURUNO products have a battery(ies). To see if your product has a battery, see the chapter on Maintenance. Follow the instructions below if a battery is used. Tape the + and - terminals of battery before disposal to prevent fire, heat generation caused by short circuit.

In the European Union

The crossed-out trash can symbol indicates that all types of batteries must not be discarded in standard trash, or at a trash site. Take the used batteries to a battery collection site according to your national legislation and the Batteries Directive 2006/66/EU.

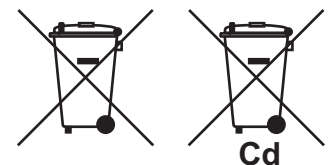

In the USA

The Mobius loop symbol (three chasing arrows) indicates that Ni-Cd and lead-acid rechargeable batteries must be recycled. Take the used batteries to a battery collection site according to local laws.

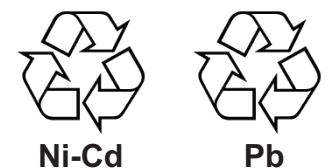





In the other countries

There are no international standards for the battery recycle symbol. The number of symbols can increase when the other countries make their own recycle symbols in the future.







SAFETY INSTRUCTIONS

The operator of this equipment must read these safety instructions before attempting to operate the equipment.

 WARNING	Indicates a potentially hazardous situation which, if not avoided, could result in death or serious injury.
 CAUTION	Indicates a potentially hazardous situation which, if not avoided, may result in minor or moderate injury.

 Warning, Caution	 Prohibitive Action	 Mandatory Action
--	--	--





Safety instructions for the operator

 WARNING
 Do not open the equipment. Only qualified personnel should work inside the equipment.
 Do not disassemble or modify the equipment. Fire or electrical shock can result if the equipment is modified.
 Do not operate the equipment with wet hands. Electrical shock can result.
 Make sure no rain or water splash leaks into the equipment. Fire or electrical shock can result if water leaks into the equipment.
 Immediately turn off the power at the switchboard if water leaks into the equipment. Continued use of the equipment can cause fire or electrical shock.

Warning Label

A warning label is attached to the equipment. Do not remove the label. If the label is missing or damaged, contact a FURUNO agent or dealer about replacement.

Safety instructions for the installer

 WARNING						
 Turn off the power at the switch-board before beginning the installation. Turn off the power to prevent electrical shock.						
 Make sure the installation site is not subject to water spray. Fire or electrical shock can result if water leaks into the equipment.						
 CAUTION						
 Observe the following compass safe distances to prevent interference to the instruments: <table border="1" style="margin: 10px auto; width: 80%;"> <thead> <tr> <th></th> <th>Standard compass</th> <th>Steering compass</th> </tr> </thead> <tbody> <tr> <td>FI-50 series Instruments</td> <td style="text-align: center;">0.35 m</td> <td style="text-align: center;">0.30 m</td> </tr> </tbody> </table>		Standard compass	Steering compass	FI-50 series Instruments	0.35 m	0.30 m
	Standard compass	Steering compass				
FI-50 series Instruments	0.35 m	0.30 m				

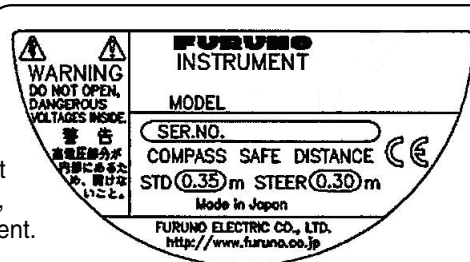

TABLE OF CONTENTS

- FOREWORD..... iv**
- SYSTEM CONFIGURATION vi**

- 1. FI-501 WIND ANGLE, FI-502 CLOSE HAULED WIND ANGLE..... 1**
 - 1.1 Operating Controls 1
 - 1.2 Turning the Power On/Off 2
 - 1.3 Adjusting Brilliance and Contrast 2
 - 1.4 Display Layout..... 3
 - 1.5 Selecting a Display 4
 - 1.6 Selecting Apparent or True Wind Angle, Wind Speed 5
 - 1.7 Displaying Velocity Made Good (VMG) Information 6
 - 1.8 Displaying Tack Angle 6
 - 1.9 Alarms 7

- 2. FI-505 COURSE PILOT 9**
 - 2.1 Operating Controls 9
 - 2.2 Turning the Power On/Off 10
 - 2.3 Adjusting Brilliance and Contrast 10
 - 2.4 Selecting a Display 11
 - 2.5 Unlocked and Locked Heading Modes..... 12
 - 2.6 Resetting Average Heading Indication 12

- 3. FI-506 RUDDER..... 13**
 - 3.1 Operating Controls 13
 - 3.2 Turning the Power On/Off 14
 - 3.3 Adjusting Display Brilliance 14
 - 3.4 Calibrating Rudder Angle 14

- 4. MAINTENANCE, TROUBLESHOOTING 15**
 - 4.1 Preventive Maintenance 15
 - 4.2 Troubleshooting..... 16

- 5. INSTALLATION 17**
 - 5.1 Equipment Lists..... 17
 - 5.2 Mounting..... 19
 - 5.3 Wiring 23
 - 5.4 Setting Up..... 29

- SPECIFICATIONS SP-1**
- PACKING LIST A-1**
- OUTLINE DRAWINGS..... D-1**
- INTERCONNECTION DIAGRAM S-1**

FOREWORD

A Word to the Owner of the FI-501, FI-502, FI-505, FI-506

Congratulations on your choice of the FURUNO FI-501 Wind Angle, FI-502 Close Hauled Wind Angle, FI-505 Course Pilot and the FI-506 Rudder, members of the FI-50 series of marine instruments. We are confident you will see why the FURUNO name has become synonymous with quality and reliability.

Since 1948, FURUNO Electric Company has enjoyed an enviable reputation for quality marine electronics equipment. This dedication to excellence is furthered by our extensive global network of agents and dealers.

This equipment is designed and constructed to meet the rigorous demands of the marine environment. However, no machine can perform its intended function unless operated and maintained properly. Please carefully read and follow the recommended procedures for operation and maintenance.

Thank you for considering and purchasing FURUNO equipment.

Features

The FI-50 series provide various analog and digital navigation and environmental data, with digital data displayed on a high quality, backlit LCD. The sturdy weather-proof case is built to stand up to even the harshest of environments.

FI-501, FI-502

The FI-501 Wind Angle and FI-502 Close Hauled Wind Angle provide precise analog wind angle together with digital speed indication. Wind angle is available in True or Apparent.

The main features of the FI-501 and FI-502 are

- True and apparent wind angle and speed
- Maximum wind speed
- Velocity made good
- Tack angle
- Alarms for wind speed and wind angle
- Boat speed
- Boat speed, heading

FI-505

The FI-505 Course Pilot displays heading and course information, and its main features are

- Heading and average heading
- Locked heading
- Course made good
- Adjustments for
 - Heading response
 - Pointer response
 - Course made good response
 - Pointer alignment

FI-506

The FI-506 Rudder displays rudder angle, and its main features are

- Analog rudder indication
- Alignment with keypads

SYSTEM CONFIGURATION

Standalone configuration

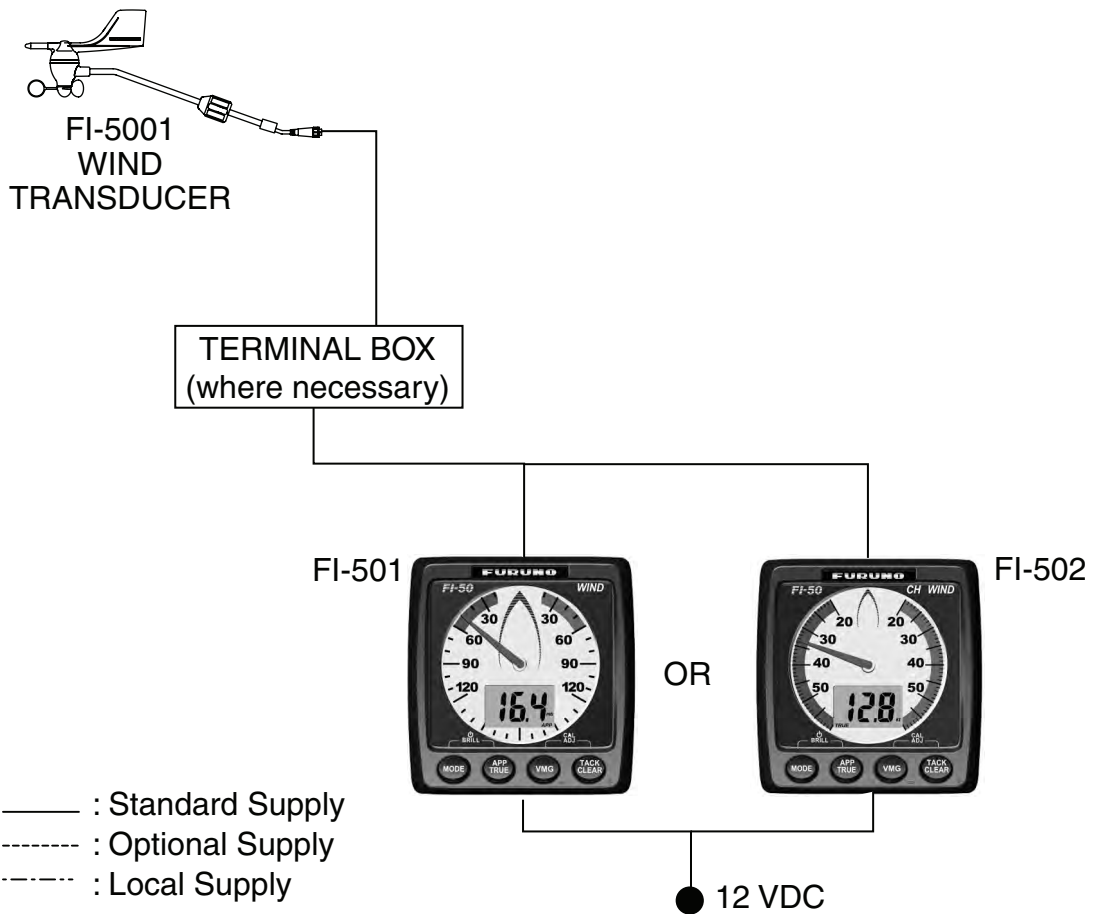

FI-501/FI-502

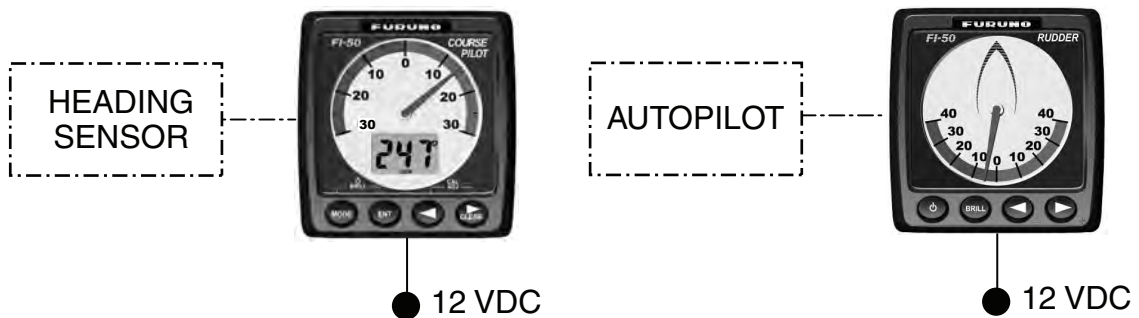

FI-505

FI-506

NOTICE: Turn on the terminal resistor in the instrument when connecting a CAN bus device or an NMEA 2000 sensor. For the procedure, see installation chapter.

CAN bus network

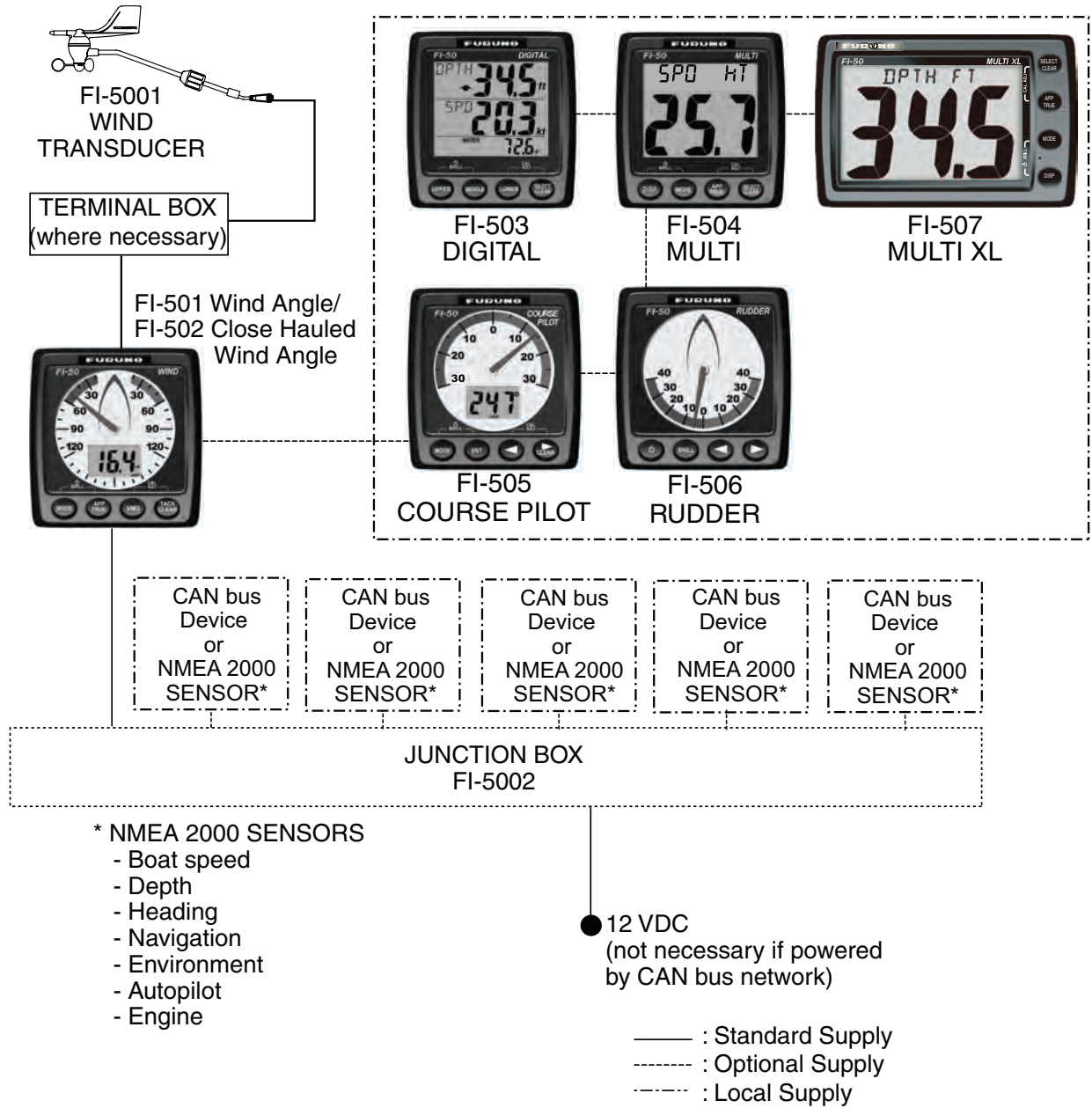

NOTICE: Turn on the terminal resistor in the terminator of the CAN bus network.

SYSTEM CONFIGURATION

This page is intentionally left blank.

1. FI-501 WIND ANGLE FI-502 CLOSE HAULED WIND ANGLE

The FI-501 Wind Angle and FI-502 Close Hauled Wind Angle instruments provide precise analog wind angle together with digital speed indication, in true or apparent direction. Wind speed is displayed in knots, meters/second or as a Beaufort scale number.

In addition to wind direction and speed indications these instruments provide:

- Velocity made good (VMG).
- Alarms for minimum and maximum true wind speeds, and high and low apparent wind angles.

1.1 Operating Controls

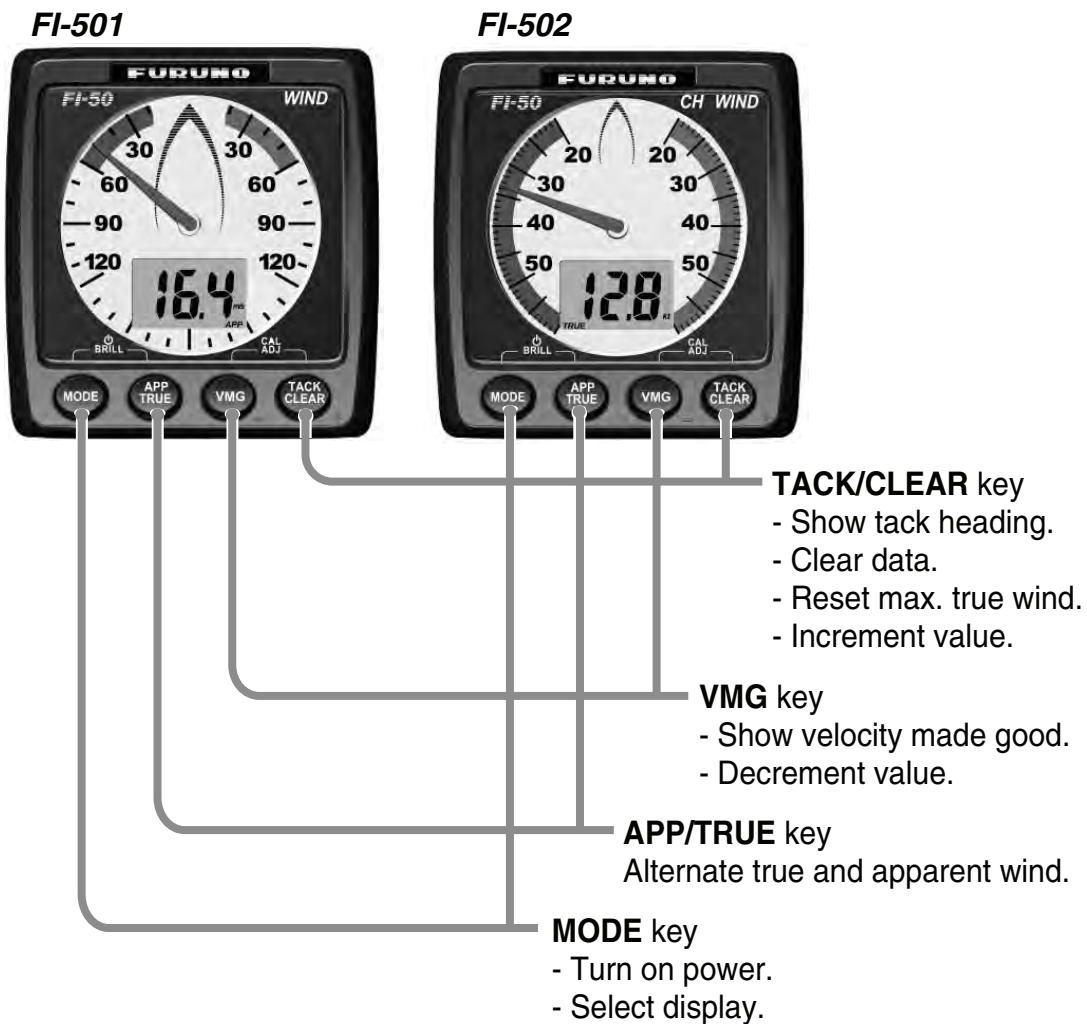

1.2 Turning the Power On/Off

To power the instrument, press the **MODE** key. All LCD segments go on and off and then the last-used display appears.

To power off the instrument, press the **MODE** and **APP/TRUE** keys together. The timer appears and counts down from three seconds to one second, and then the power goes off.

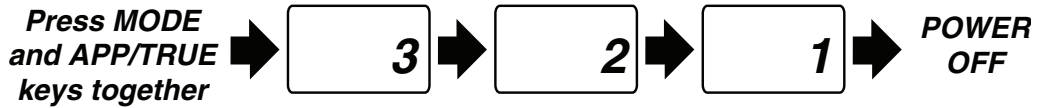

Power OFF sequence

1.3 Adjusting Brilliance and Contrast

1. Press the **MODE** and **APP/TRUE** keys together. The display for adjustment of brilliance appears, with current brilliance setting flashing.

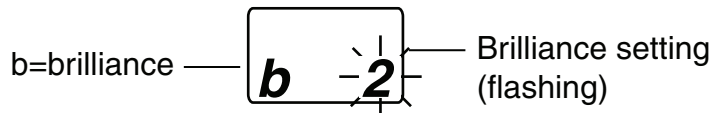

2. Within seven seconds of completing step 1, press the **VMG** key to lower the brilliance, or the **TACK/CLEAR** key to raise it.

3. Press the **MODE** and **APP/TRUE** keys together. The display for adjustment of contrast appears, with current contrast setting flashing.

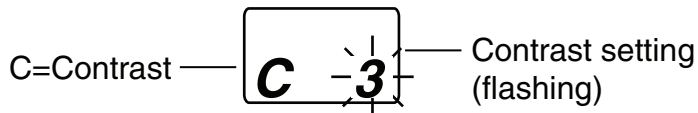

4. Within seven seconds of completing step 3, press the **VMG** key to lower the contrast, or the **TACK/CLEAR** key to raise it.

5. Press the **MODE** and **APP/TRUE** keys together to save the settings and restore normal operation.

The brilliance and contrast will be the same on all units which are synchronized. (For how to synchronize units, see page 32.)

1.4 Display Layout

The FI-501 Wind Angle and FI-502 Close Hauled Wind Angle instruments provide analog dial and digital wind information. The display shows that information in true or apparent, depending on mode selected.

The pointer shows the true or apparent wind direction. The apparent wind scale range for the FI-501 is 360° (0°-179° starboard, 180°-359° port) and the FI-502 gives an indication of -60° to +60°, about the port and starboard of your boat.

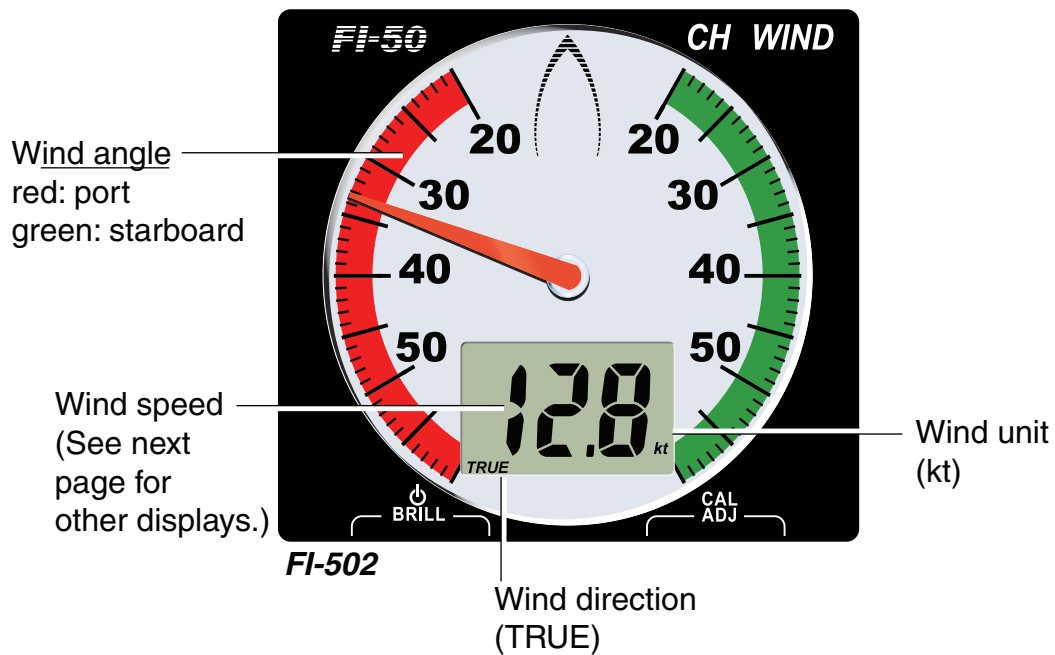
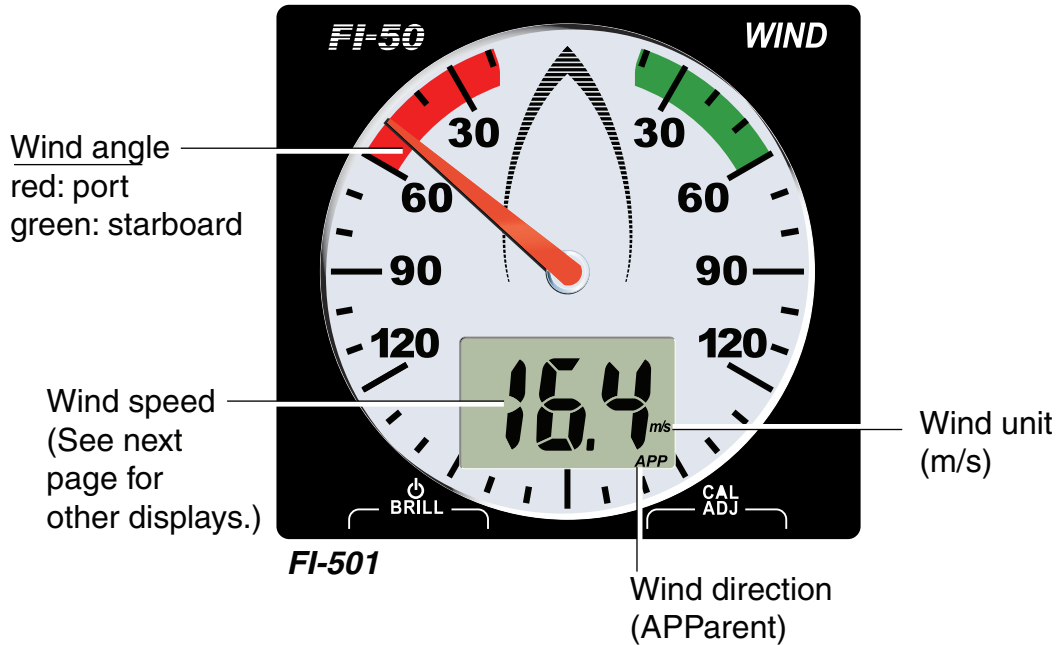

Displays

1.5 Selecting a Display

Press the **MODE** key to select a display. Each press of the key changes the display in the sequence shown below.

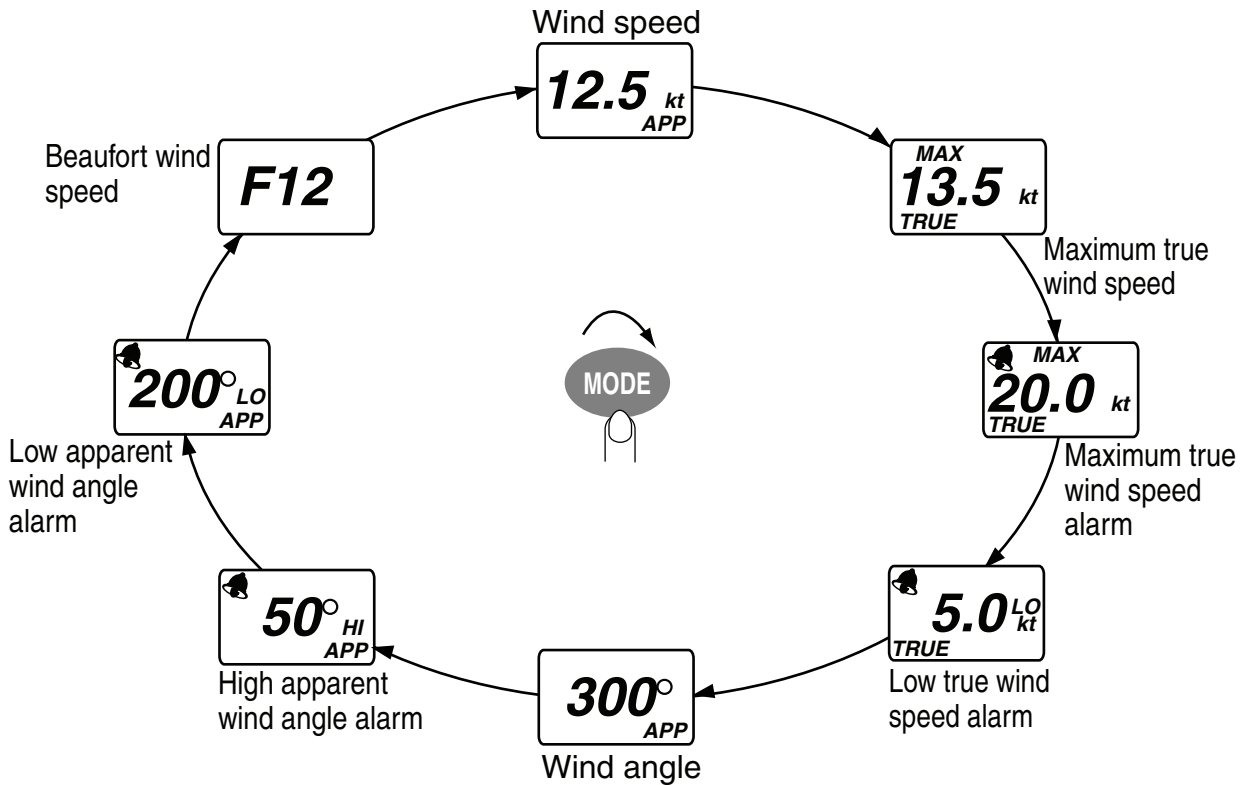

Display	Function	Display	Function
	Wind speed. Kt or m/s; true or apparent wind.		Wind angle. Kt or m/s; true or apparent wind.
	Maximum wind speed. Kt or m/s, true or apparent wind. Resettable with the TACK/CLEAR key.		Set maximum true wind angle alarm.*
	Set maximum true wind speed alarm.*		Set low true wind angle alarm.*
	Set low true wind speed alarm.*		Beaufort wind speed. Beaufort speeds up to 12 are shown. See the table at the top of the next page for Beaufort no. and wind speed.

* Audio and visual alarms released when wind speed (or wind angle) is higher (or lower) than threshold value.

Beaufort no. and wind speed

Beaufort no.	Wind speed		Beaufort no.	Wind speed	
	kt	m/s		kt	m/s
0	0	0-0.2	7	28-33	14.4-17.4
1	1-3	0.5-2.0	8	34-40	17.5-21.0
2	4-6	2.1-3.5	9	41-47	21.1-24.6
3	7-10	3.6-5.6	10	48-55	24.7-28.8
4	11-16	5.7-8.6	11	56-63	28.9-32.6
5	17-21	8.7-11.2	12	64	32.7-32.9
6	22-27	11.3-14.3			

1.6 Selecting Apparent or True Wind Angle, Wind Speed

You can show wind angle and wind speed in apparent or true wind. The **apparent wind** is the actual flow of air acting upon a sail, or the wind as it appears to the sailor. **True wind** is the wind seen by a stationary observer in velocity and direction.

With a wind angle or wind speed indication displayed, press the **APP/TRUE** key to change the wind angle or wind speed to apparent and true alternately. A beep sounds after the change is completed. (Wind angle and wind speed displays are mutually changed.) True wind requires boat speed input. If there is no speed input three dashes appear.

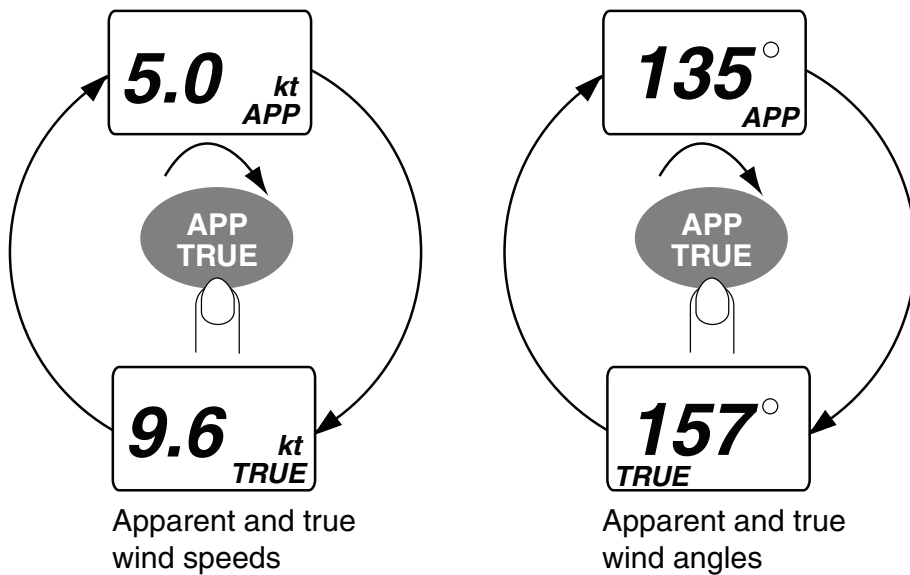

1.7 Displaying Velocity Made Good (VMG) Information

VMG is the actual vessel speed after adjusting for such factors as current and wind.

Use the **VMG** key to display and erase VMG information and current display alternately. (The VMG information cannot be shown when an alarm display is currently shown.). The VMG display requires boat speed information. If no boat speed is available three dashes is shown.

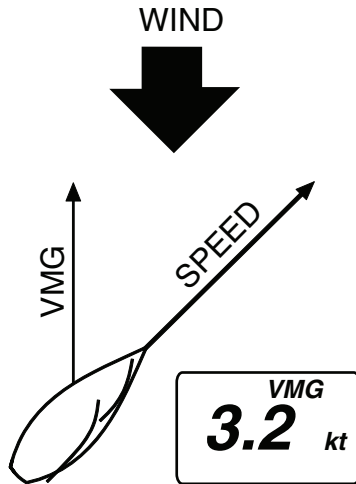

1.8 Displaying Tack Angle

Use the **TACK/CLEAR** key to display tack angle on the digital display. This function requires speed and heading information. If they are not available, the digital display shows three dashes.

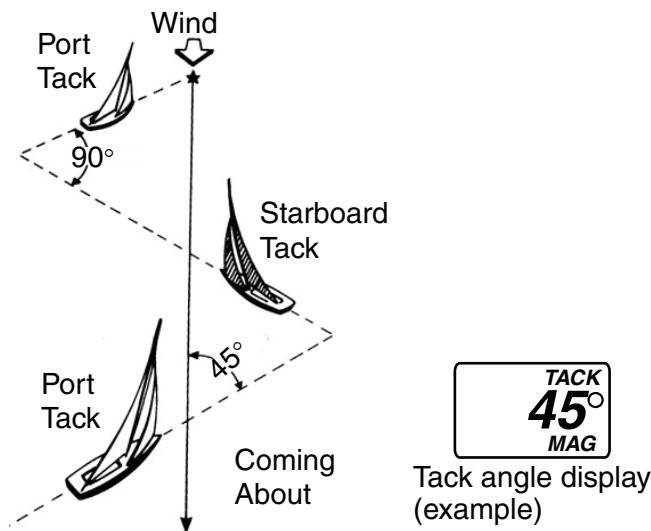

1.9 Alarms

There are four conditions which trigger audio and visual alarms: Maximum true wind speed, Low true wind speed, High apparent wind angle, and Low apparent wind angle.

1. Press the **MODE** key to select desired alarm page, referring to the illustration below.



Max. true wind speed alarm

Low true wind speed alarm

High apparent wind angle alarm

Low apparent wind angle alarm

Alarm	Alarm released when;	Setting range	
Max. true wind speed alarm	wind speed exceeds this threshold.	0.1-999 kts	
Low true wind speed alarm	wind speed is lower than this threshold.	0-998 kts	
High apparent wind angle alarm	wind angle exceeds this threshold.	0°-179° (Starboard)	Angle side ("S" or "P") not indicated on FI-501.
Low apparent wind angle alarm	wind angle is lower than this threshold.	180°-359° (Port)	

2. If the selected alarm page shows "OFF," press and hold down the **TACK/CLEAR** key until an alarm setting appears.
3. Press the **VMG** and **TACK/CLEAR** keys together to enable adjustment. The alarm setting starts flashing.
4. Press the **VMG** key to lower the setting; the **TACK/CLEAR** key to raise it.
Note: A low alarm cannot be set higher than its affiliated high (max.) alarm.
5. Press the **VMG** and **TACK/CLEAR** keys together to confirm setting and restore normal operation.

When an alarm is violated:

- The display shows current wind speed and angle.
- The buzzer sounds and the alarm icon flashes.

You can silence the buzzer with the **TACK/CLEAR** key. The alarm icon continues flashing until the offending alarm is disabled.

While the icon is flashing you can switch between alarm display and current display alternately by pressing the **MODE** and **TACK/CLEAR** keys together.

1. FI-501 WIND ANGLE, FI-502 CLOSE HAULED WIND ANGLE

This page is intentionally left blank.

2. FI-505 COURSE PILOT

The FI-505 Course Pilot provides compass heading, in digital format. In the locked mode, steering error to $\pm 30^\circ$ deviation of locked course heading is shown, with the analog pointer.

In the unlocked mode the pointer is set to zero. In the locked mode, the pointer shows course error; that is, the difference between the current heading and the locked course.

2.1 Operating Controls

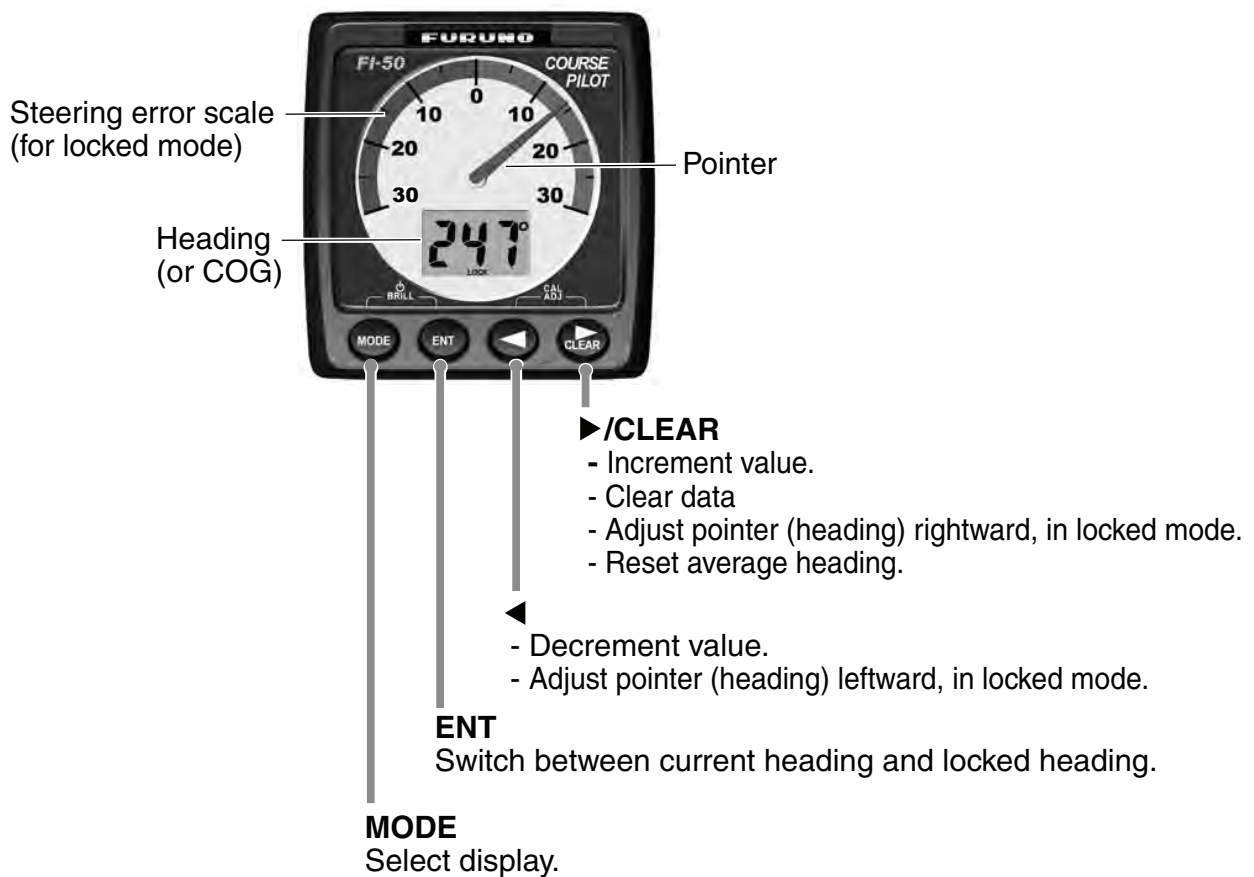

2.2 Turning the Power On/Off

To power the instrument, press the **MODE** key. All LCD segments go on and off and then the last-used display appears.

To power off the instrument, press the **MODE** and **ENT** keys together. The timer appears and counts down from three seconds to one second, and then the power goes off.

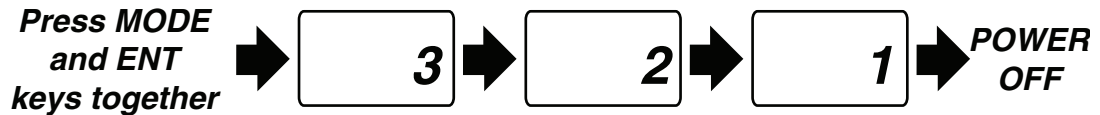

Power OFF sequence

2.3 Adjusting Brilliance and Contrast

1. Press the **MODE** and **ENT** keys together. The display for adjustment of brilliance appears, with current brilliance setting flashing.

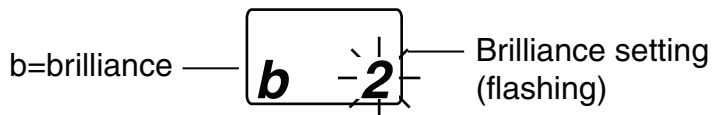

2. Within seven seconds of completing step 1, press the ◀ key to lower the brilliance, or the ▶/CLEAR key to raise it.

3. Press the **MODE** and **ENT** keys together. The display for adjustment of contrast appears, with current contrast setting flashing.

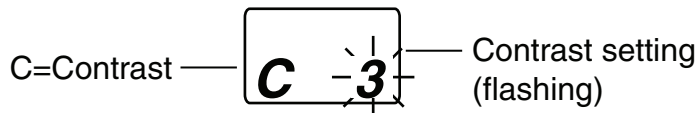

4. Within seven seconds of completing step 3, press the ◀ key to lower the contrast, or the ▶/CLEAR key to raise it.

5. Press the **MODE** and **ENT** keys together to save the settings and restore normal operation.





The brilliance and contrast will be the same on all units which are synchronized. (For how to synchronize units, see page 32.)

2.4 Selecting a Display

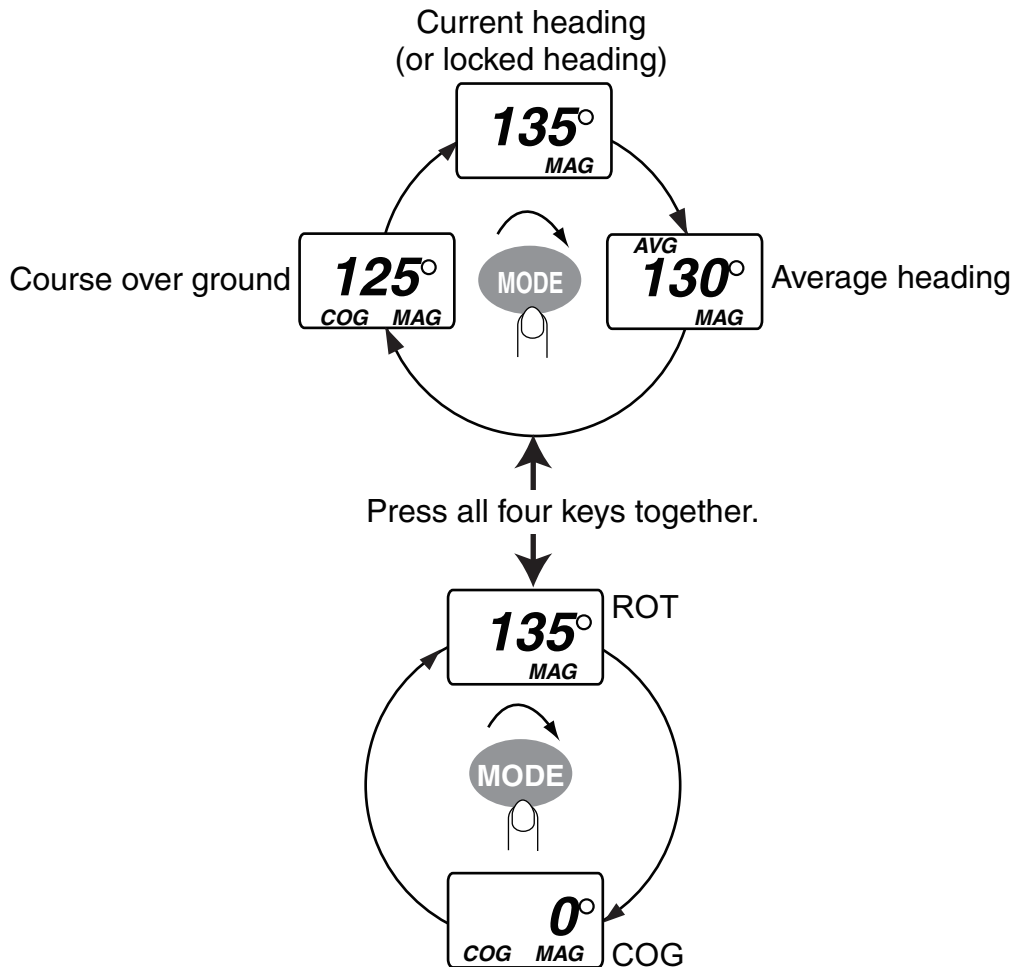
Press the **MODE** key to select a display, and the selection changes in the sequence shown below. If no heading data is available, three dashes appear on the digital display.

If you prefer to show ROT and COG (instead of heading and COG), press all four keys simultaneously until you hear a beep. Press the **MODE** key to select ROT or COG as shown below. To return to the COG and heading displays, press the keys again. The indication is ROT when it is greater than $\pm 30^\circ$

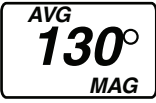

Display	Function	Display	Function
	Heading, shown in true or magnetic, selectable on the setup1 menu. See the chapter on installation for details.		Course over ground (COG). COG is the direction of movement relative to the earth. GPS information is required.
	Average heading. You can reset this value with the ►/CLEAR key. See section 2.6.		ROT (Rate of Turn).

2.5 Unlocked and Locked Heading Modes

In the **unlocked mode**, the digital display shows the current heading, true or magnetic, and the pointer is at zero. The unit always starts up in the unlocked mode.

In the **locked mode**, the operator sets a fixed (locked) heading, with the arrow keys. The digital display shows either locked heading or current heading, depending on calibration setting. The pointer shows the difference between the locked heading and the actual course being steered; that is, heading error.

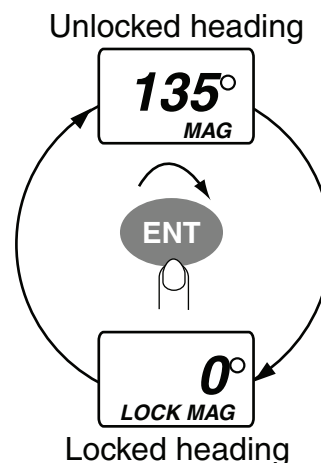

You can switch between the unlock mode and the locked mode with the **ENT** key.

Setting locked heading

When you enter the locked mode, the current heading becomes the locked heading. Then, the digital display shows locked heading or current heading, depending on the setup1 menu setting. To change the locked heading, use the ◀ key to shift the heading leftward.



2.6 Resetting Average Heading Indication

The average heading indication can be reset with the ▶/CLEAR key. Press and hold down the key. A short beep sounds, the indication flashes twice and then a long beep sounds to indicate that resetting is completed.

3. FI-506 RUDDER

The FI-506 Rudder displays rudder angle, in analog indication. The pointer shows the rudder position in real time. The instrument's scale range is -40° to $+40^{\circ}$ about zero.

The FI-506 operates in real time, thus almost no action is required of the operator other than confirming the rudder angle and adjustment of the brilliance.

3.1 Operating Controls

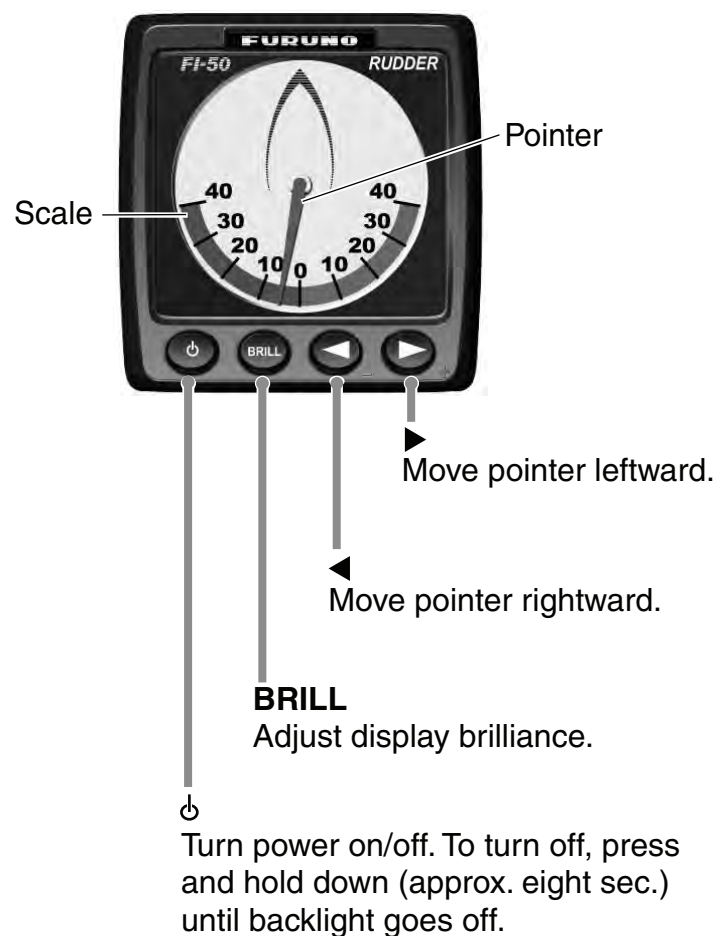

3.2 Turning the Power On/Off

To power the instrument, press the [⏏] key. After the pointer moves to current rudder angle, release the key.

To power off the instrument, press and hold down the [⏏] key until the backlight goes off.

3.3 Adjusting Display Brilliance

Use the **BRILL** key to adjust the display brilliance. There are three levels of brilliance.

The brilliance will be the same on all units which are synchronized. (For how to synchronize units, see page 32.)



3.4 Calibrating Rudder Angle

You can calibrate the rudder indication to remove any deviation from actual and displayed rudder angles.

1. With the rudder centered, press the ◀ and ▶ keys together until the instrument starts beeping continuously. The beeping indicates you have correctly enabled the calibration mode.
2. Use the ◀ or ▶ key to move the pointer to the zero position.
3. Press ◀ and ▶ keys together again to save the setting and escape from the calibration mode.

4. MAINTENANCE, TROUBLESHOOTING

This chapter provides the information necessary for keeping your equipment in good working order.

 WARNING	
	Do not open the equipment. Only qualified personnel should work inside the equipment.

4.1 Preventive Maintenance

Following the recommended procedures below will help maintain performance.

Check item	Check point	Remedy
Cabling	Check that all cabling is securely fastened and is free of rust and corrosion.	Reconnect if necessary. Replace if damaged.
Cabinet	Dust on cabinet	Remove dust with a soft, lint-free cloth. <div data-bbox="858 1220 1380 1568" style="border: 1px solid black; padding: 5px;"><p style="text-align: center;">NOTICE</p><p>Do not apply paint, anti-corrosive sealant or contact spray to coating or plastic parts of the equipment.</p><p>Those items contain organic solvents that can damage coating and plastic parts, especially plastic connectors.</p></div>

4.2 Troubleshooting

If you feel the equipment is not functioning properly, follow the procedures in the table below to try to restore normal operation. If normal operation cannot be restored, do not attempt to check inside the cabinet. There are no user-serviceable parts inside.

Troubleshooting

Problem	Possible cause	Remedy
Power cannot be turned on	<ul style="list-style-type: none"> • Power supply • Cabling disconnected or damaged. 	<ul style="list-style-type: none"> • Check power supply. • Check cabling.
Power is on but no data	<ul style="list-style-type: none"> • Cable from sensor is damaged or disconnected. 	<ul style="list-style-type: none"> • Check sensor.
Inaccurate data	<ul style="list-style-type: none"> • Electromagnetic field generating equipment is in operation. • Sensor is improperly aligned. 	<ul style="list-style-type: none"> • Turn off all electromagnetic field generating equipment. Turn them on and off one by one. Check the display. Relocate offending equipment if necessary. • Check installation.

5. INSTALLATION

NOTICE

Do not apply paint, anti-corrosive sealant or contact spray to coating or plastic parts of the equipment.

Those items contain organic solvents that can damage coating and plastic parts, especially plastic connectors.

5.1 Equipment Lists

Standard supply for FI-501 WIND ANGLE

Name	Type	Code No.	Qty	Remarks	
Display Unit	FI-501	-	1		
Wind Transducer	FI-5001	-	1		
Installation Materials	CP26-00100	000-011-739	1 set	For display unit	See packing list at end of manual for details.
	CP26-00201	001-026-600	1 set	For wind transducer	
	CP26-00300	000-010-511	Select one.	30 m cable, terminal box	
	CP26-00400	000-010-618		50 m cable, terminal box	

Standard supply for FI-502 CH WIND ANGLE

Name	Type	Code No.	Qty	Remarks
Display Unit	FI-502	-	1	
Installation Materials	CP26-00500	000-011-742	1 set	See packing list at end of manual for details.

Standard supply for FI-505 COURSE PILOT

Name	Type	Code No.	Qty	Remarks
Display Unit	FI-505	-	1	
Installation Materials	CP26-00500	000-011-742	1 set	See packing list at end of manual for details.

5. INSTALLATION

Standard supply for FI-506 RUDDER

Name	Type	Code No.	Qty	Remarks
Display Unit	FI-506	-	1	
Installation Materials	CP26-00500	000-011-742	1 set	See packing list at end of manual for details.

Optional supply

Name	Type	Code No.	Qty	Remarks
Wind Transducer	FI-5001	-	1 set	For FI-502
Terminal Box	FI-5001-TERMINAL	000-010-913	1 set	For FI-5001
Cable Assy.	FI-50-DROP	000-166-945-10	1	
	FI-50-CHAIN-0.3M	000-166-949-10	1	
	FI-50-CHAIN-5M	000-166-951-10	1	
	FI-50-CHAIN-1M	000-166-950-10	1	
	FI-50-CHAIN-10M	000-166-952-10	1	
	FI-50-CHAIN-20M	000-166-953-10	1	
Flush Mount Kit	FI-50-FLUSH-KIT	000-010-619	1 set	
Installation Materials	CP26-00300	000-010-511	1 set	30 m cable, for FI-5001
	CP26-00400	000-010-618	1 set	50 m cable, for FI-5001
Junction Box	FI-5002	000-010-765	1 set	See packing list at end of manual for details.

5.2 Mounting

5.2.1 Wind Transducer FI-5001 (for FI-501, FI-502)

Installation site

Fix the transducer to the mounting mast so that its mounting base is parallel with the water line. Also, position the transducer so its leading edge faces the bow.

Mounting procedure

1. Orient the mounting base as shown in the figure below, with the threaded part of the mounting base facing the bow. Fix the mounting base to the mast with four self-tapping screws (supplied).

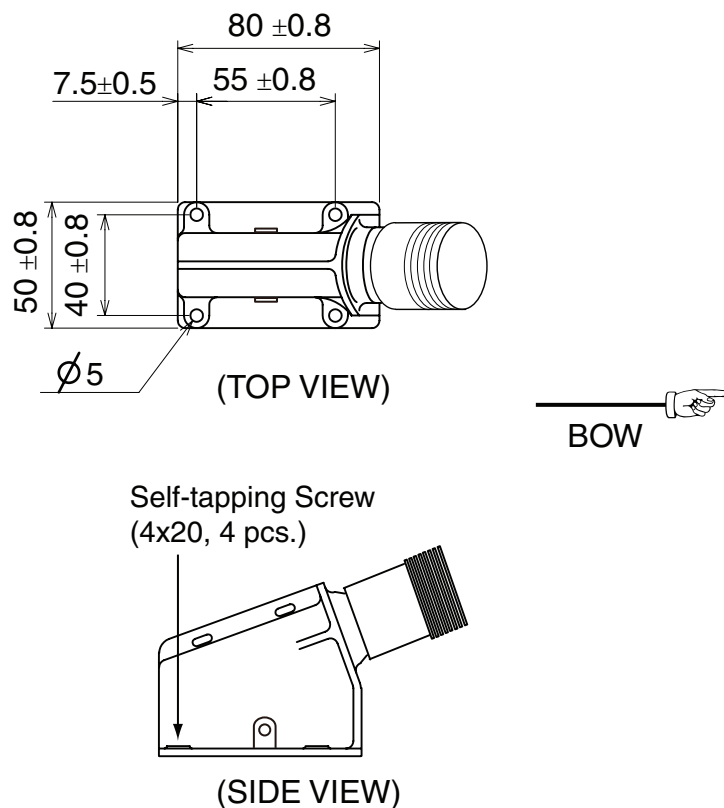

2. Pass the connector on the transducer through the hole in the mounting base and then screw the cap on the transducer into the mounting base.
3. Set the lock fitting to the holes on both sides of the mounting base and push the lock fitting onto the shaft until you hear a “click.” See the figure at the top of the next page.

5. INSTALLATION

- Mate the connector at the rear of the transducer to cable assy.
FI-50-SENSOR-30/50 (30 m or 50 m, supplied).

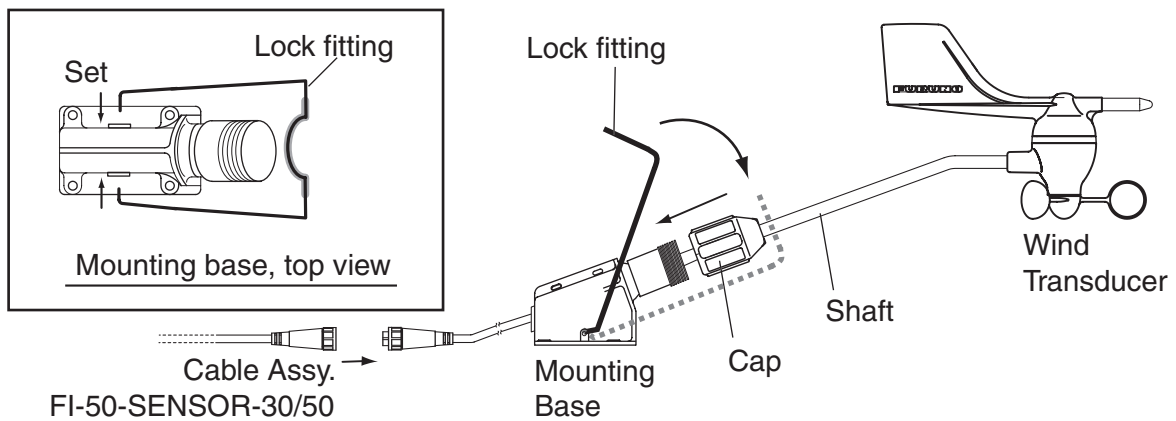

- As shown in the figure below, make a loop in the cable assy. Fix the cable to the mounting base with two cable ties (local supply).

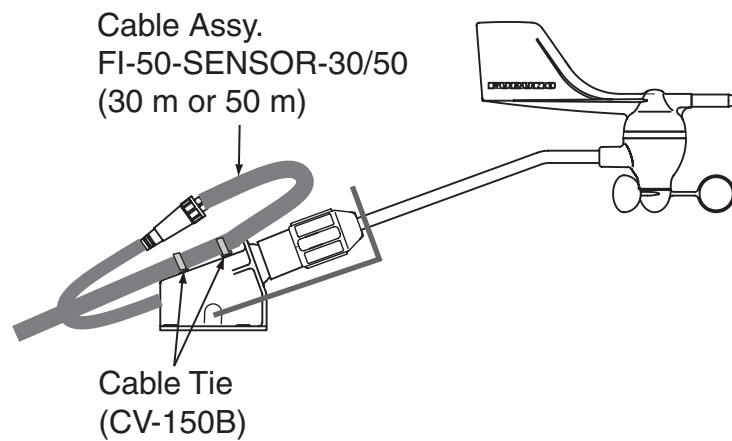

- Pass the cable assy. through the mast and connect it to the FI-501/FI-502. If the connector of the cable cannot be passed through the mast (because mast diameter is too small), use the terminal box (supplied) to make the connection. For how to use the terminal box, see page 25.

5.2.2 Display unit

The display unit can be installed two ways: surface mount (two ways) or flush mount (optional kit required). This section covers surface mounting. For flush mounting, see the flush mounting instructions, issued separately.

Surface mount 1: Fix instrument from front panel

1. Using the template at the back of this manual, open a mounting hole in the installation site.
2. Detach the front panel together with the keypad assy. Attach sponge (supplied) to rear of display unit.
3. Set the display unit to the mounting hole and fix it with four self-tapping screws (3×20, supplied).
4. Attach the front panel and keypad assy. to the display unit.

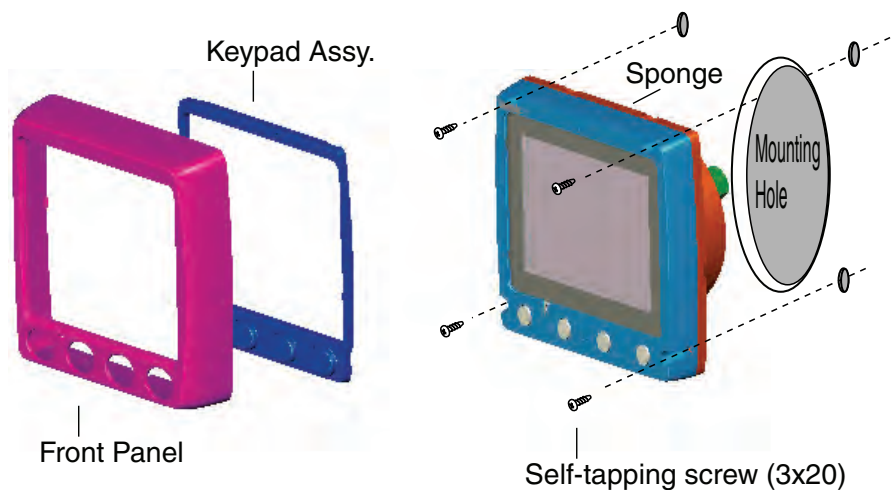

5. INSTALLATION

Surface mount 2: Fix instrument from rear panel

1. Using the template at the back of this manual, open a mounting hole in the installation site.
2. Insert studs (M3x40, 2 pcs., supplied) in the holes shown below. (Use only the studs supplied.).

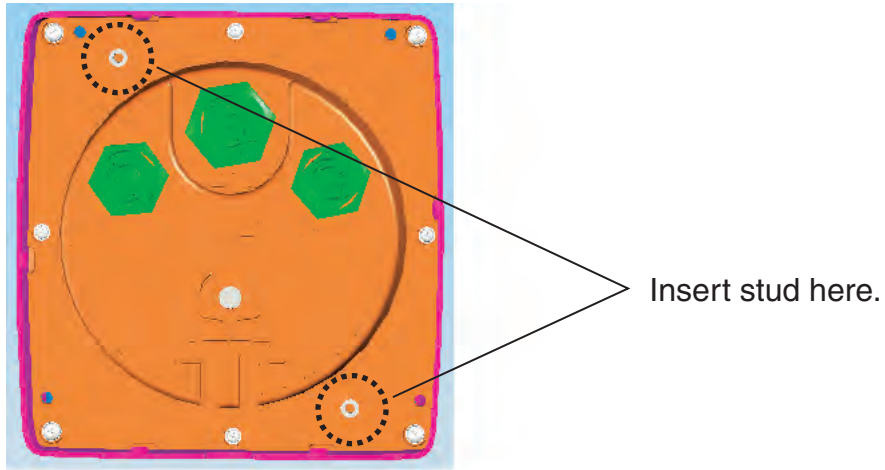

3. Set the display unit to the mounting hole, inserting studs through respective holes. Fix the display unit with wing nuts (M3, supplied).

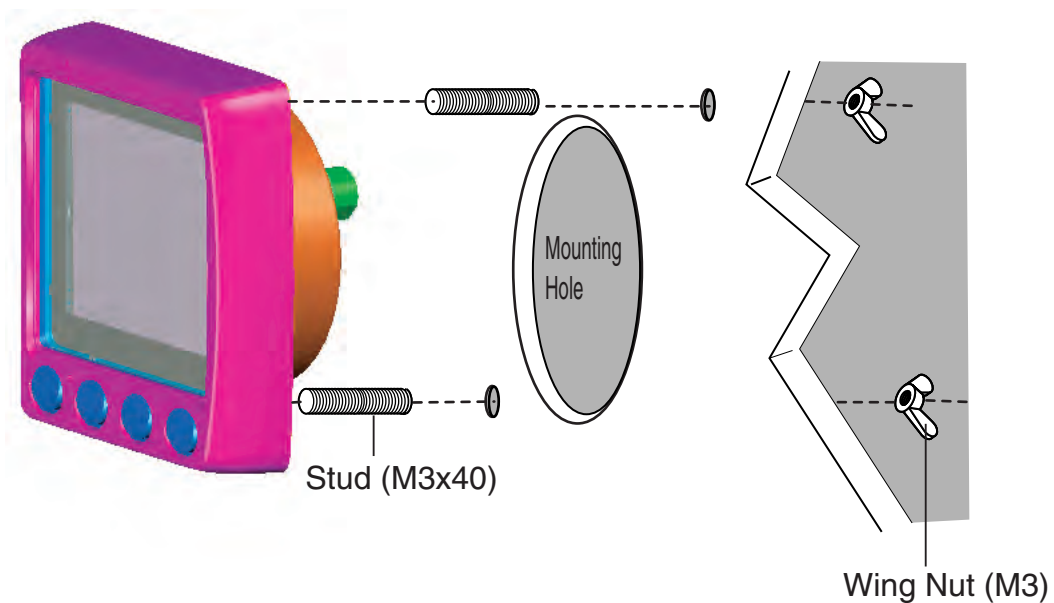

5.3 Wiring

For the service technician, detailed information about CAN bus wiring is on the FURUNO Tech-Net. See “Furuno CAN bus Network Design Guide” (TIE-00170-*).

5.3.1 Standalone configuration

For standalone configuration the junction box is not necessary; connect the instrument directly to the power supply.

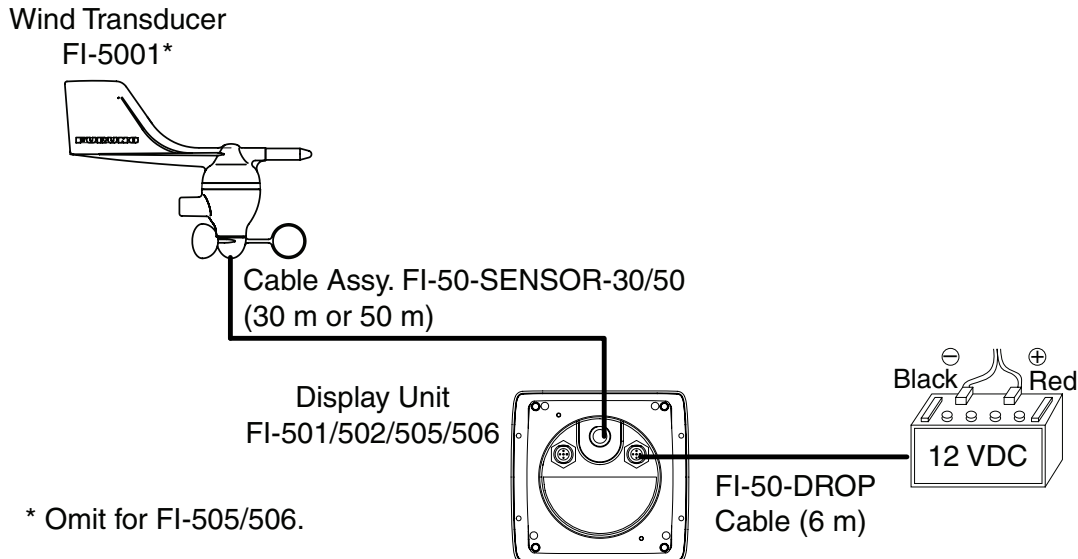

Note: Turn on the display unit’s terminal resistor. For the procedure, see page 33 (FI-501/502/505 or page 35 (FI-506).

Using the terminal box

As shown in the figure above, the display unit is connected to the wind transducer with the cable assy. FI-50-SENSOR-30/50. However, if the connector of the cable cannot be passed through the mast (because its diameter is too small), use the Terminal Box to make the connection. Wire it as shown on the next page. The box is not waterproof; locate it out of areas subject to rain or water splash. The length of the cable between the FI-5001 and display units is maximum 50 m.

1. Cut the connector from the FI-50-SENSOR-30/50 cable and pass the cable thru the mast.

5. INSTALLATION

2. Fabricate the above-mentioned cables as shown below.

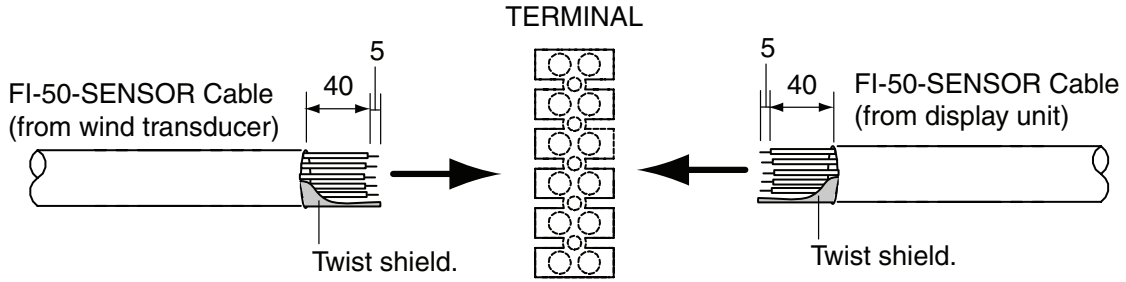

3. Unfasten two self-tapping screws to remove the cover of the terminal box.
4. Connect the cables to the terminal inside the terminal box, referring to the interconnection diagram. Bind wires with cable ties at the locations shown below.

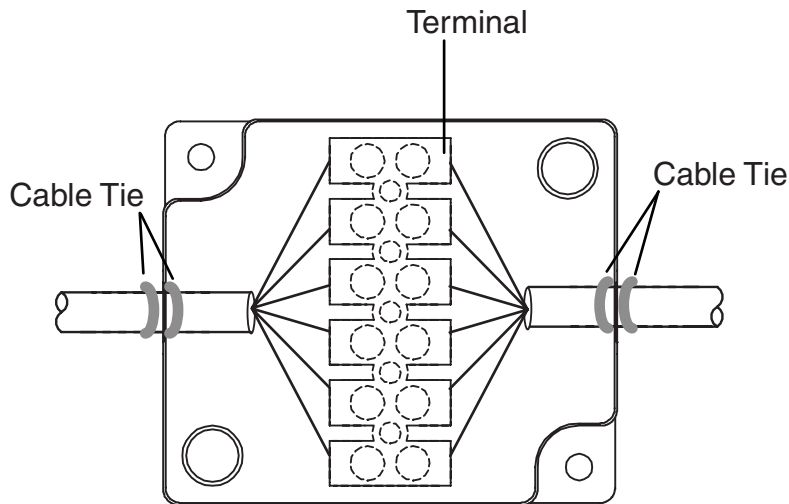

5. Fasten the cover with the screws removed at step 4. Use two self-tapping screws (M3×12, supplied) to fix the terminal box.

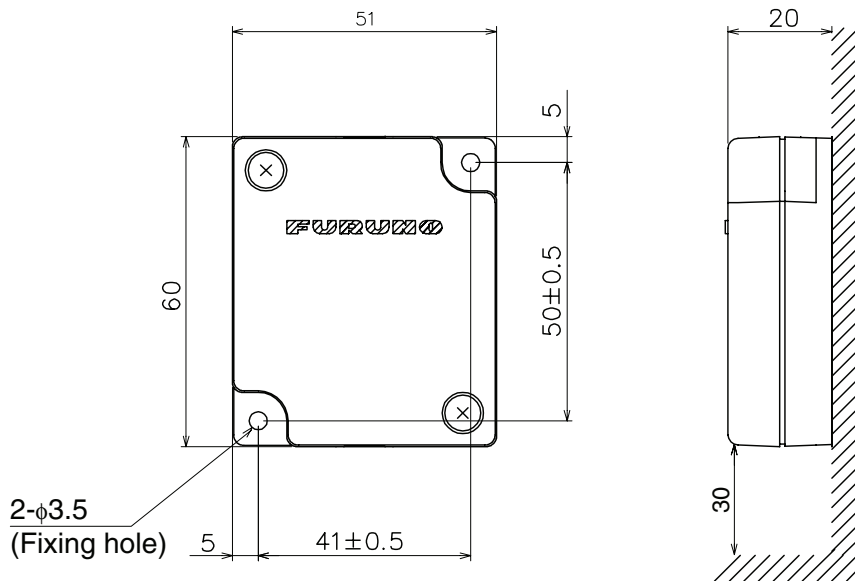

5.3.2 CAN bus network configuration

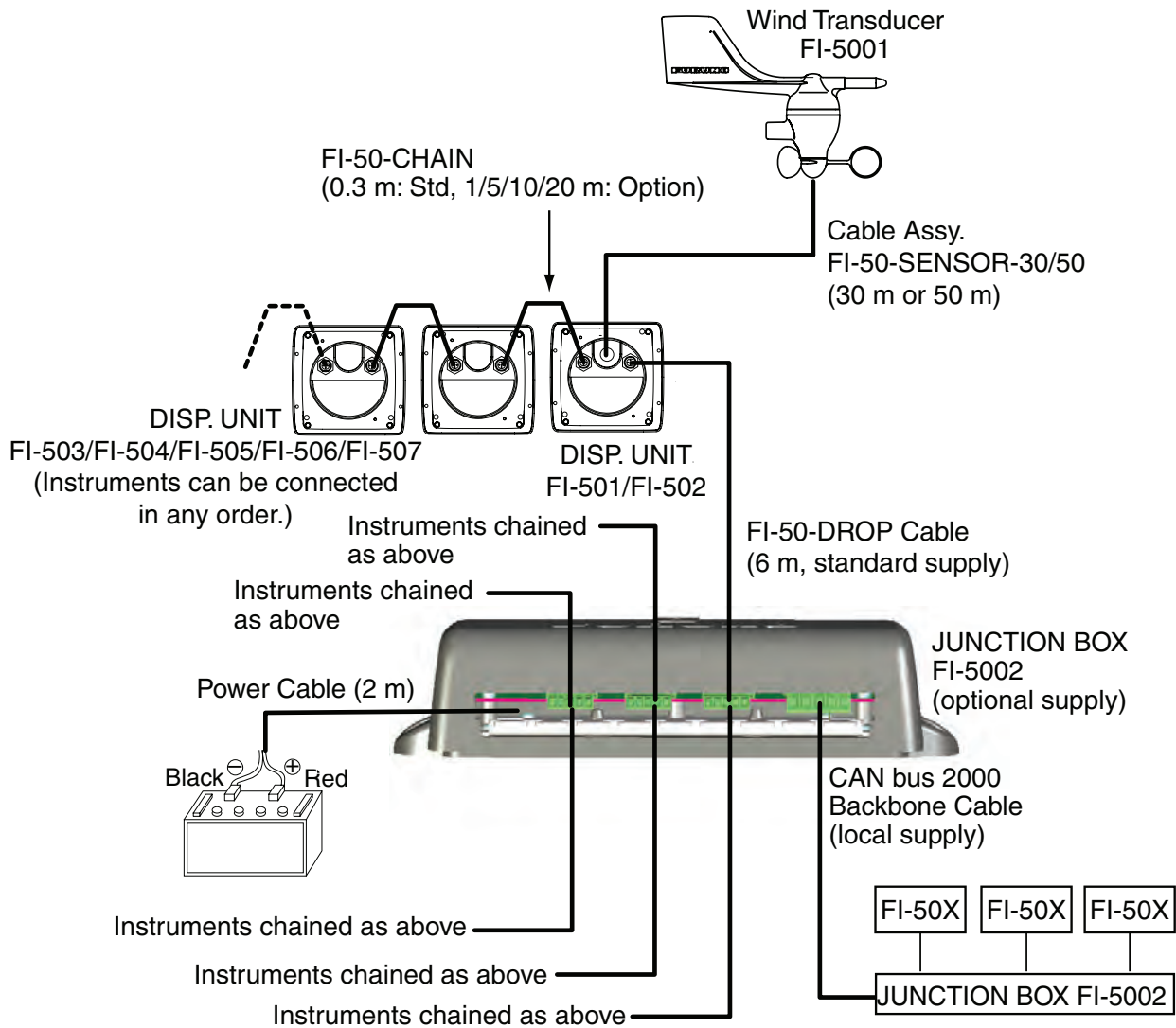

NOTE: The total length of drop cables and backbone cables must be within 80 m.

Junction box (option)

The junction box is required when connecting CAN bus network. This section covers wiring of the junction box. For how to mount the junction box, see its installation instructions, issued separately.

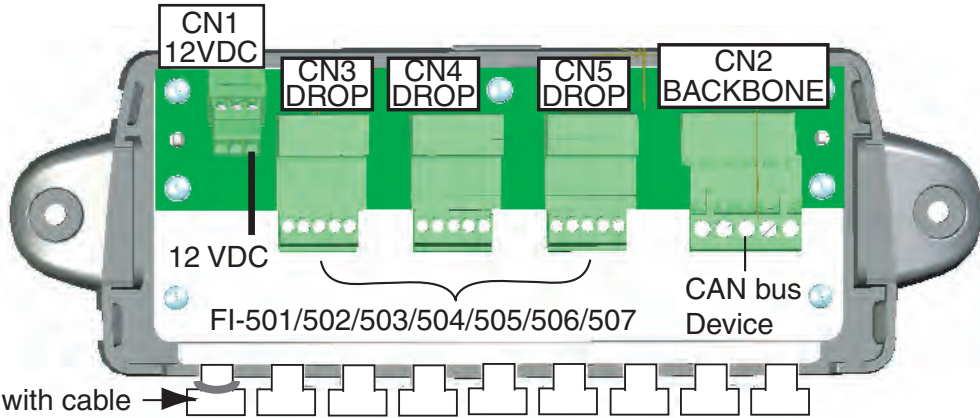

CN3 DROP - CN5 DROP and BACKBONE are socket-and-plug-type terminal blocks. Detach plug to connect wiring to it, by rocking it back and forth with your fingers. Remove approx. 6 mm of the sheath from the end of wires and twist wires. Loosen fixing screw in the plug, insert wire into hole and tighten fixing screw. Set plug to socket.

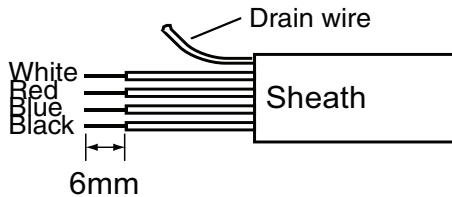

How to fabricate cable

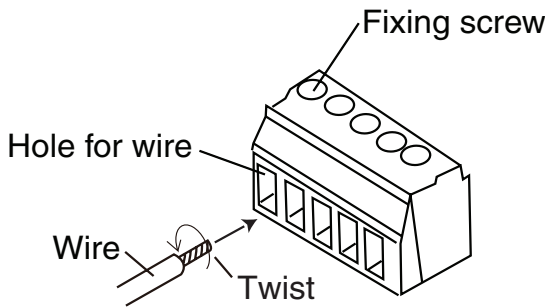

How to insert wire

Terminal resistor

The illustration below show various system configurations and what units to activate the terminal resistor.

Smart sensor+FI-50x

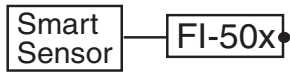

Multiple FI-50 series instruments, FI-5002, drop cabling

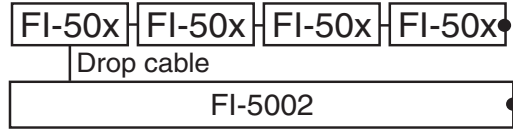

Multiple FI-50 series instruments, FI-5002

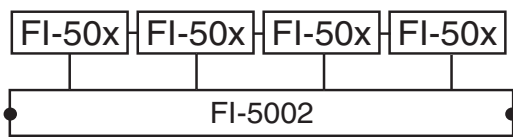

Multiple FI-50 series instruments, multiple FI-5002

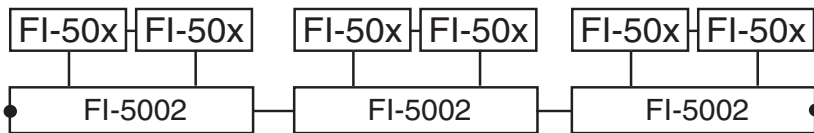

Multiple FI-50 series instruments, FI-5002, smart sensor

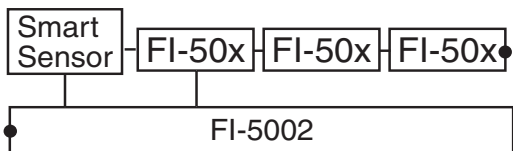

Multiple FI-50 series instruments, FI-5002, heading sensor, smart sensor

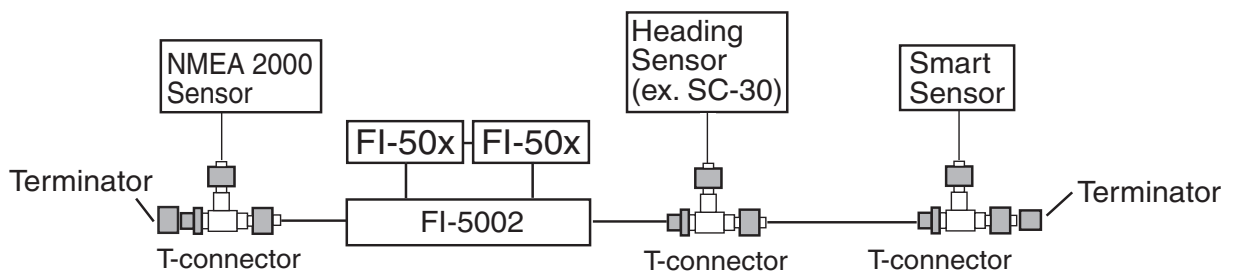

Multiple FI-50 series instruments, FI-5002, NMEA 2000, CAN bus sensors

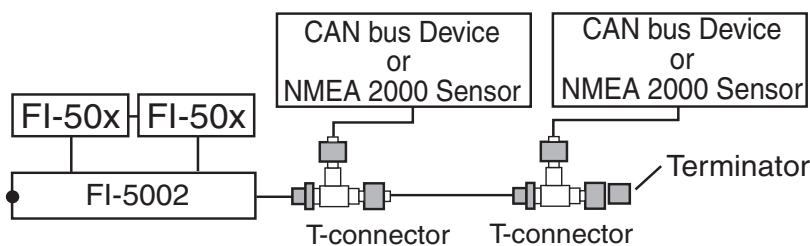

• = Terminal resistor ON

5. INSTALLATION

Turn on the terminal resistor in the junction box when the NMEA 2000 sensor(s) connected to it do not have a terminal resistor.

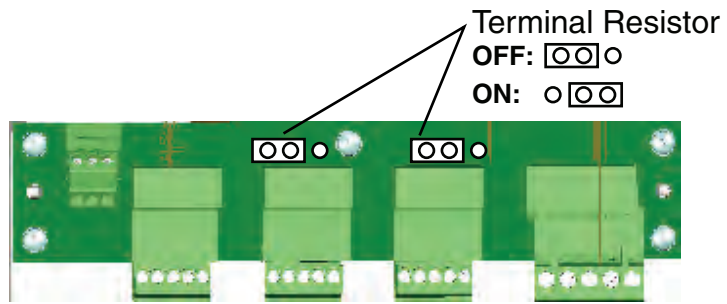

For how to turn on the terminal resistor in a FI-50 series instrument, see page 33 (FI-501//FI-502/FI-505) or page 35 (FI-506).

5.4 Setting Up

Your instrument is pre-programmed with factory default settings, which may or may not be suited to your vessel. Therefore, it is necessary to initialize the instrument for use with your vessel. This should be done immediately after completion of the installation.

Two sets of setup menus are provided: setup1 and setup2. The setup1 menu provides system parameters and setup2 has user settings.

The procedure for setting up the instruments is mainly the same; the only difference is the key names. You use the **MODE** key and the 3rd and 4th keys from the left to do the setting up.

5.4.1 Setting up FI-501/FI-502/FI-505

Setup1 menu

The setup1 menu optimizes the instrument for use on your vessel. Follow the procedure below to access and set the items on this menu.

1. Press the 3rd and 4th keys from the left together momentarily. The first menu item for respective model appears, with current setting flashing.
2. Press the **MODE** key to choose a menu item. Each press of the key changes the menu item in the sequence shown below.

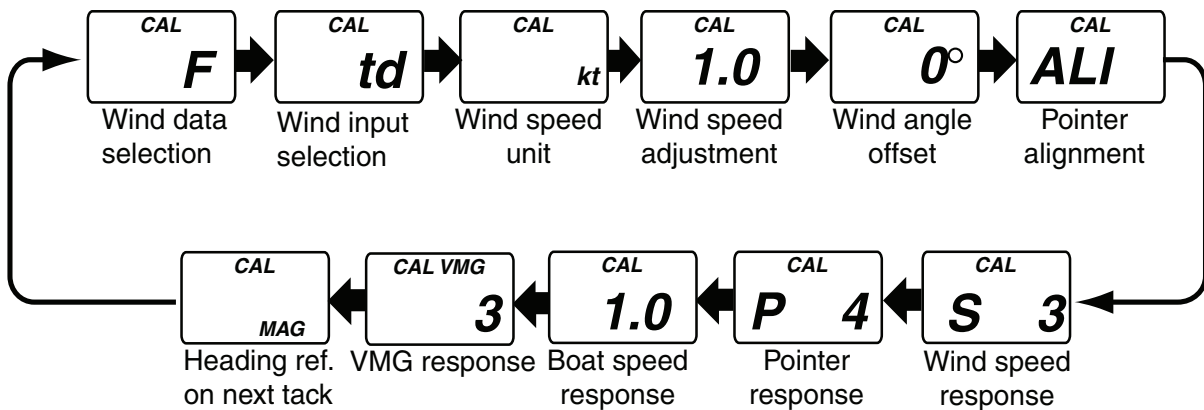

Setup1 menu items for FI-501, FI-502

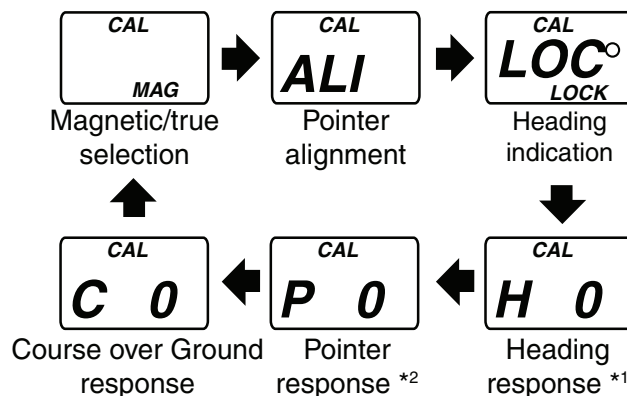

*1 ROT response when ROT is selected for display.
*2 ROT pointer response when ROT is selected for display.

Setup1 menu items for FI-505





5. INSTALLATION

3. Use the 3rd and 4th keys to set a value or select option.
 3rd key: Decrement value.
 4th key: Increment value or select option.
4. To continue, press the **MODE** key to select another item.
5. To save settings and restore normal operation, press the 3rd and 4th keys together.

Setup1 menu items for FI-501, FI-502

Display	Function	Setting range or options	Default setting
CAL F	Select source of wind data. Select "r" for second unit.	F: For FI-5001, r: repeater	F
CAL td	Select source of wind input.	td: Transducer, Fr: FURUNO repeater	td
CAL kt	Select wind speed unit.	kt, m/s	kt
CAL 1.0	Set wind speed adjustment.	0.3 - 2.5	1.0
CAL 0°	Set wind angle offset.	0° - 359°	0
CAL ALI	Align pointer to zero. Operate the VMG or TACK/CLEAR key until the pointer is at zero.		
CAL S 3	Set wind speed response. The lower the value the faster the response.	0 - 12	3
CAL P 4	Set wind pointer response. The lower the value the faster the response.	0 - 12	4
CAL 1.00	Set boat speed adjustment (for VMG). (STW only)	0.30 - 2.50	1.00
CAL VMG 3	Set velocity made good response. The lower the value the faster the response.	0 - 12	3
CAL MAG	Set heading reference on next tack.	MAG(netic), TRUE	MAG

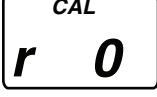
Setup1 menu items for FI-505

Menu item (in sequential order)	Function	Setting range or options	Default setting
	Select bearing reference.	MAG: Magnetic, TRUE: True	MAG
	Align pointer to zero. Operate the ◀ key or the ▶/CLEAR key until the pointer is at zero.		
	Enables/disables use of locked heading. Choose LOC to enable locked heading.	LOC: Locked, Cur: Current	LOC
	Set heading response. The lower the setting the faster the response to change in heading. (Set ROT response when ROT is selected for display.)	0 - 12	0
	Set pointer response. The lower the setting the faster the pointer responds. (Set ROT pointer response when ROT is selected for display.)	0 - 12	0
	Set course over ground response. The lower the setting the higher the response to changed in course over ground.	0 - 12	0

Setup2 menu

The setup2 menu contains items which once preset do not require frequent adjustment. This menu is mostly operated the same as the setup1 menu. The only difference is how long the 3rd and 4th keys are pressed to activate the menu.

1. Press the 3rd and 4th keys together (about 5-6 seconds) until the software version screen for CPU1 appears. (See the illustration below.)
2. Press the **MODE** key to select a menu item. Each press of the key changes the menu item in the sequence shown in the illustration at the top of the next page.

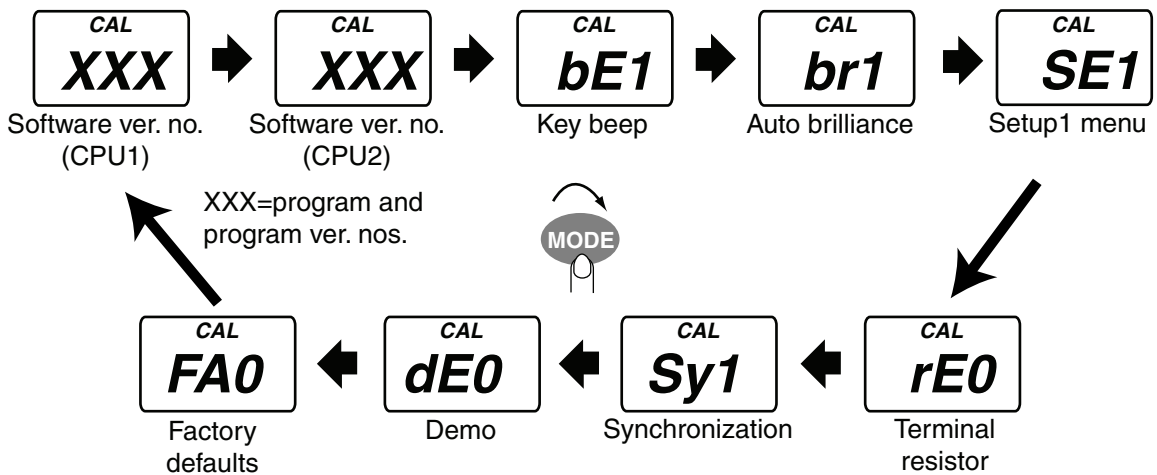

3. Use the 4th key to select ON or OFF as applicable.
4. To continue, press the **MODE** key to select another item.
5. To save settings and restore normal operation, press the 3rd and 4th keys together.

Setup2 menu items

Display	Function	Options	Default setting
CAL XXx	Software version of CPU1. XX=program no. and x=program version no.	-	-
CAL XXx	Software version of CPU2. XX=program no. and x=program version no	-	-
CAL bE1	Key beep on/off.	1: ON, 0: OFF	1(ON)
CAL br1	Adjust brilliance automatically with environment.	1: ON, 0: OFF	1(ON)
CAL SE1	Enable/disable access to the setup1 menu.	1: ON, 0: OFF	1(ON)
CAL rE0	Terminal resistor on/off.	1: ON, 0: OFF	0(OFF)
CAL Sy1	Turn on/off synchronization of FI-50 series instruments.	1: ON Synchronize all FI-50 instruments having this setting. A: Synchronize FI-50 instruments having this setting. b: Synchronize FI-50 instruments having this setting. 0: Turn off synchronization.	1(ON)
CAL dE0	Demo mode on/off. To turn on/off, press the 4th key about four seconds.	1: ON, 0: OFF	0(OFF)
CAL FA0	Restore factory defaults. To restore factory defaults, press and hold down the 4th key until "0" is replaced with "1" and then press the key again within two seconds.	1: ON, 0: OFF	0(OFF)

5.4.2 Setting up FI-506

Rudder calibration

You can apply an offset to the rudder indication to remove any deviation from actual and displayed rudder angles.

1. With the rudder centered, press the ◀ and ▶ keys together until the instrument starts beeping continuously. The beeping indicates you have correctly enabled the calibration mode.
2. Use the ◀ and ▶ keys to move the pointer to the zero position.
3. Press the ◀ and ▶ keys together again to save the setting and escape from the calibration mode.

Terminal resistor on/off

The terminal resistor enables/disables connection of the FI-506 to an NMEA 2000 network, and it is disabled at the factory. To turn the resistor on or off, press and hold down the **BRILL** and ◀ keys together until you hear a beep. Then, press the ▶ key to turn the resistor on or off. The number of beeps indicates ON or OFF. Two beeps for ON, three beeps for OFF. Press the **BRILL** and ◀ keys together to save the setting and return to normal operation. A beep sounds upon completion.

Synchronization on/off

The data shared within the FI-50 instruments series can be synchronized, so that all data agrees. You can turn synchronization of all data on or off, or synchronize data by group, A and/or B. For group synchronization, instruments having like group synchronization settings are synchronized.

To set synchronization, press and hold down the **BRILL** and ▶ keys together until you hear a beep. Then, press the ▶ key to select applicable synchronization setting. The number of beeps and beep duration indicate the setting as shown below. Press the **BRILL** and ▶ keys together to save the setting and return to normal operation. A beep sounds upon completion.

ON: Beep^{*1}→OFF^{*1}→Beep^{*1}
 A: Beep^{*1}→OFF^{*1}→Beep^{*3}
 B: Beep^{*3}→OFF^{*1}→Beep^{*1}→OFF^{*1}→Beep^{*1}→OFF^{*1}→Beep^{*1}
 OFF: Beep^{*3}→OFF^{*2}→Beep^{*3}→OFF^{*2}→Beep^{*3}
 *1 200 ms, *2 500 ms, *3 1000 ms

Factory defaults

Press the ⏏ and **BRILL** keys together until you hear a beep, indicating completion. Press the same keys again to return to normal operation.

SPECIFICATIONS OF FI-501 WIND ANGLE FI-502 CLOSE HAULED WIND ANGLE

1 GENERAL

- | | | |
|-----|-----------------------|---|
| 1.1 | Display | Analog and segment LCD |
| 1.2 | Display Content | Wind angle, wind speed, VMG, tack heading |
| 1.3 | Analog Meter Range | $\pm 180^\circ$ (FI-501), $\pm 60^\circ$ (FI-502) |
| 1.4 | Analog Meter Accuracy | $\pm 10^\circ$ (FI-501), $\pm 5^\circ$ (FI-502) |
| 1.5 | I/O Port | - CAN bus: 2 ports
- Wind sensor input: 1 port |

2 WIND TRANSDUCER

- | | | |
|-----|-------------------------------------|---|
| 2.1 | Wind Angle Measurement Range | 0-360° |
| 2.2 | Wind Direction Measurement Accuracy | $\pm 10^\circ$ |
| 2.3 | Wind Speed Measurement Range | 0.9 kt – 90 kt |
| 2.4 | Wind Speed Measurement Accuracy | Up to 20 kt: ± 1 kt, More than 20 kt: $\pm 5\%$ |
| 2.5 | Response | Within one second |

3 JUNCTION BOX (OPTION)

- | | | |
|-----|------------------|---------|
| 3.1 | No. of I/O ports | |
| | CAN bus Device | 6 ports |
| | CAN bus Backbone | 2 ports |

4 POWER SUPPLY AND POWER CONSUMPTION

- | | | |
|-----|-----------------|--|
| 4.1 | Display Unit | 12 VDC, less than 0.1 A |
| 4.2 | Junction Box | 12 VDC, less than 1 A, max. 2A connectable |
| 4.3 | Wind Transducer | 12 VDC, less than 50 mA |

5 ENVIRONMENTAL CONDITIONS

- | | | |
|-----|---------------------------|--|
| 5.1 | Useable Temperature Range | $-15^\circ\text{C} - +55^\circ\text{C}$ |
| 5.2 | Relative Humidity | Less than 95% ($+40^\circ\text{C}$) |
| 5.3 | Waterproofing | Display Unit IP56
Junction Box IPX0 |
| 5.4 | Vibration | - 2 Hz-5 Hz and up to 13.2 Hz with an excursion of ± 1 mm $\pm 10\%$ (7 m/s^2 maximum acceleration at 13.2 Hz);
- above 13.2 Hz and up to 100 Hz with a constant maximum acceleration of 7 m/s^2 |

6 COATING COLOR

- | | | |
|-----|--------------|------|
| 6.1 | Display Unit | N2.5 |
| 6.2 | Junction Box | N2.5 |

SPECIFICATIONS OF FI-505 COURSE PILOT

1 GENERAL

1.1	Display	Analog and digital LCD
1.2	Display Content	Heading
1.3	Analog Meter Display Range	$\pm 30^\circ$
1.4	Analog Meter Display Accuracy	$\pm 3^\circ$
1.5	I/O Port	CAN bus, 2 ports

2 JUNCTION BOX (OPTION)

2.1	No. of I/O ports	
	CAN bus Device	6 ports
	CAN bus Backbone	2 ports

3 POWER SUPPLY AND POWER CONSUMPTION

3.1	Display Unit	12 VDC, less than 0.1 A
3.2	Junction Box	12 VDC, less than 1 A, max. 2A connectable

4 ENVIRONMENTAL CONDITIONS

4.1	Useable Temperature Range	$-15^\circ\text{C} - +55^\circ\text{C}$
4.2	Relative Humidity	Less than 95% ($+40^\circ\text{C}$)
4.3	Waterproofing	
	Display Unit	IP56
	Junction Box	IPX0
4.4	Vibration	- 2 Hz-5 Hz and up to 13.2 Hz with an excursion of $\pm 1\text{ mm} \pm 10\%$ (7 m/s^2 maximum acceleration at 13.2 Hz); - above 13.2 Hz and up to 100 Hz with a constant maximum acceleration of 7 m/s^2

5 COATING COLOR

5.1	Display Unit	N2.5
5.2	Junction Box	N2.5

SPECIFICATIONS OF FI-506 RUDDER

1 GENERAL

- | | | |
|-----|-------------------------------|------------------|
| 1.1 | Display | Analog |
| 1.2 | Analog Meter Display Range | $\pm 40^\circ$ |
| 1.3 | Analog Meter Display Accuracy | $\pm 5^\circ$ |
| 1.4 | I/O Port | CAN bus, 2 ports |

2 JUNCTION BOX (OPTION)

- | | | |
|-----|------------------|---------|
| 2.1 | No. of I/O ports | |
| | CAN bus Device | 6 ports |
| | CAN bus Backbone | 2 ports |

3 POWER SUPPLY AND POWER CONSUMPTION

- | | | |
|-----|--------------|--|
| 3.1 | Display Unit | 12 VDC, less than 0.1 A |
| 3.2 | Junction Box | 12 VDC, less than 1 A, max. 2A connectable A |

4 ENVIRONMENTAL CONDITIONS

- | | | |
|-----|---------------------------|--|
| 4.1 | Useable Temperature Range | $-15^\circ\text{C} - +55^\circ\text{C}$ |
| 4.2 | Relative Humidity | Less than 95% ($+40^\circ\text{C}$) |
| 4.3 | Waterproofing | |
| | Display Unit | IP56 |
| | Junction Box | IPX0 |
| 4.4 | Vibration | - 2 Hz-5 Hz and up to 13.2 Hz with an excursion of $\pm 1 \text{ mm} \pm 10\%$ (7 m/s^2 maximum acceleration at 13.2 Hz);
- above 13.2 Hz and up to 100 Hz with constant maximum acceleration of 7 m/s^2 |

5 COATING COLOR



- | | | |
|-----|--------------|------|
| 5.1 | Display Unit | N2.5 |
| 5.2 | Junction Box | N2.5 |

This page intentionally left blank.

PACKING LIST FI-503

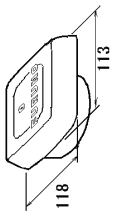
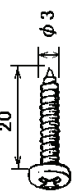
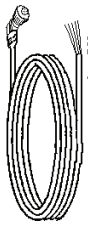
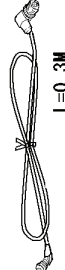
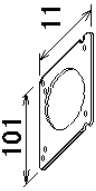
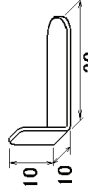

26AA-X-9859-4

1/1

NAME	UNIT	OUTLINE	DESCRIPTION/CODE No.	Q'TY
表示部	MONITOR UNIT		FI-503 000-011-743-00	1
CP26-00600				
工事材料 INSTALLATION MATERIALS				
+	ナハ`タツピ`ンネン 1ｼｼ		3X20 SUS304 000-163-884-10	4
	SELF-TAPPING SCREW			
	ケーブル組品		FI-50-DROP-6M 001-105-810-10	1
	CABLE ASSEMBLY			
	ケーブル組品0.3M		FI-50-CHAIN-0.3M 001-105-820-10	1
	CABLE ASSEMBLY 0.3M			
	サフエヌマウントスポ`ンヅ		TZ7583002A0 000-167-832-10	1
	SPONGE			
	パ`ネリム`ハ`		19-028-3124-1 100-340-471-10	1
	PANEL REMOVER			
	バ`ネ座金		M3 SUS304 000-167-404-10	2
	SPRING WASHER			
	ミカ`キ丸平座金		M3 SUS304 000-167-453-10	2
	FLAT WASHER			

コード番号末尾の「**」は、選用品の代表コードを表します。
CODE NUMBER ENDING WITH "**" INDICATES THE CODE NUMBER OF REPRESENTATIVE MATERIAL.

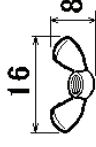
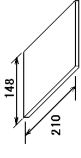
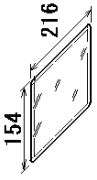
(略図の寸法は、参考値です。DIMENSIONS IN DRAWING FOR REFERENCE ONLY.)

NAME	OUTLINE	DESCRIPTION/CODE No.	Q'TY
寸切ボ`ルト		M3X40 SUS304	2
BOLT		000-167-804-10	
蝶ナット		M3 SUS304	2
WING NUT		000-167-826-10	
図書 DOCUMENT			
取扱説明書		OME-72680-*	1
OPERATOR'S MANUAL		000-167-329-1*	
操作要領書		OS*-72680-*	1
OPERATOR'S GUIDE		000-167-294-1*	**
内部終端/設定		C72-00705-*	1
INTERNAL RESISTOR		000-168-501-1*	

A-1

型式/コード番号が2段の場合、下段より上段に代わる過渡期品であり、どちらが入っています。なお、品質は変わりません。
TWO TYPES AND CODES MAY BE LISTED FOR AN ITEM. THE LOWER PRODUCT MAY BE SHIPPED IN PLACE OF THE UPPER PRODUCT. QUALITY IS THE SAME.

C7268-Z01-D

PACKING LIST

26AA-X-9853 -2 1/1

A-2

FI-5001

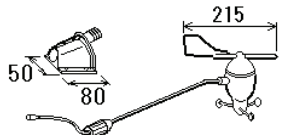
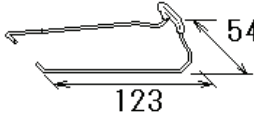
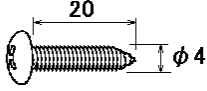
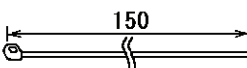
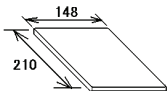
NAME	OUTLINE	DESCRIPTION/CODE No.	Q'TY
ユニット UNIT			
風向風速センサー WIND TRANSDUCER		FI-5001 000-011-740-00	1
付属品 ACCESSORIES		FP26-00201	
ロック金具S LOCK FITTINGS		FI-5001S-LOCK 000-171-683-10	1
工事材料 INSTALLATION MATERIALS		CP26-00201	
+トラスタップンネジ 1シュ SELF-TAPPING SCREW		4X20 SUS304 000-158-850-10	4
コンベックス CABLE TIE		CV-150B 000-167-183-10	2
図書 DOCUMENT			
装備要領書 INSTALLATION MANUAL		IMC-72661-* 7/エイ 000-167-285-1*	1

型式/コード番号が2段の場合、下段より上段に代わる過渡期品であり、どちらかが入っています。なお、品質は変わりません。

TWO TYPES AND CODES MAY BE LISTED FOR AN ITEM. THE LOWER PRODUCT MAY BE SHIPPED IN PLACE OF THE UPPER PRODUCT. QUALITY IS THE SAME.

(略図の寸法は、参考値です。DIMENSIONS IN DRAWING FOR REFERENCE ONLY.)



C7266-Z03-C

PACKING LIST

26AA-X-9857 -1 1/1

A-3

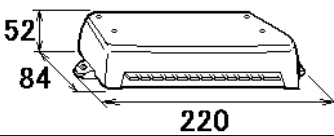
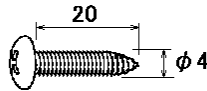
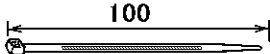
FI-5002

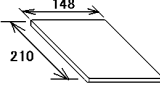
NAME	OUTLINE	DESCRIPTION/CODE No.	QTY
ユニット UNIT			
ジャンクションボックス JUNCTION BOX		FI-5002 000-011-748-00	1
工事材料 INSTALLATION MATERIALS			
+トラスタップインネジ 1シユ SELF-TAPPING SCREW		4X20 SUS304 000-158-850-10	2
結束バンド CABLE TIE		T18R 000-167-891-10	9
電源ケーブル CABLE ASSY.		FI-5002-POWERCABLE 000-166-954-11	1
図書 DOCUMENT			
取付要領書 INSTALLATION PROCEDURE		C72-00702-* ワ/エイ 000-167-315-1*	1

コード番号末尾の[**]は、選択品の代表コードを表します。

CODE NUMBER ENDING WITH "**" INDICATES THE CODE NUMBER OF REPRESENTATIVE MATERIAL.

型式/コード番号が2段の場合、下段より上段に代わる過渡期品であり、どちらかが入っています。なお、品質は変わりません。

TWO TYPES AND CODES MAY BE LISTED FOR AN ITEM. THE LOWER PRODUCT MAY BE SHIPPED IN PLACE OF THE UPPER PRODUCT. QUALITY IS THE SAME.

(略図の寸法は、参考値です。DIMENSIONS IN DRAWING FOR REFERENCE ONLY.)

C7266-Z04-B

FURUNO

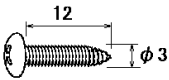
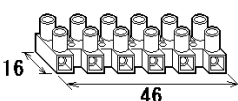
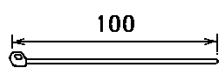
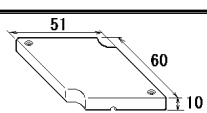
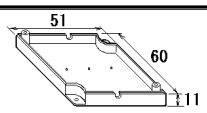
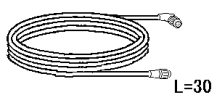
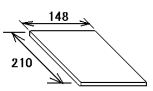
CODE NO.		000-010-511-00	26AA-X-9402 -1		
TYPE		CP26-00300	1/1		
工事材料表		INSTRUMENT FOR WIND FI-501-30			
INSTALLATION MATERIALS		FI-501			
番号 NO.	名称 NAME	略図 OUTLINE	型名/規格 DESCRIPTIONS	数量 Q'TY	用途/備考 REMARKS
1	+トラスタップ [®] ネジ [®] 1シユ SELF-TAPPING SCREW		3X12 SUS304	4	
			CODE NO. 000-167-824-10		
2	ターミナル TERMINAL		4E/6	1	
			CODE NO. 000-168-024-10		
3	コンベックス CABLE TIE		CV-100N	4	
			CODE NO. 000-162-167-10		
4	中継箱カバー COVER		MO3-9372	1	
			CODE NO. 000-167-985-10		
5	中継箱ボディ BODY		MO3-9373	1	
			CODE NO. 000-167-986-10		
6	ケーブル組品 CABLE ASSY.		FI-50-SENSOR-30M	1	
			CODE NO. 000-166-946-11		
7	装備要領書 INSTALLATION MANUAL		IMC-72661-* 7/エ1	1	
			CODE NO. 000-167-285-1*		

型式/コード番号が2段の場合、下段より上段に代わる過渡期品であり、どちらかが入っています。なお、品質は変わりません。

TWO TYPES AND CODES MAY BE LISTED FOR AN ITEM. THE LOWER PRODUCT MAY BE SHIPPED IN PLACE OF THE UPPER PRODUCT. QUALITY IS THE SAME.

(略図の寸法は、参考値です。 DIMENSIONS IN DRAWING FOR REFERENCE ONLY.)

FURUNO ELECTRIC CO., LTD.

C7266-M02-B

FURUNO

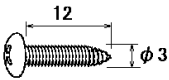
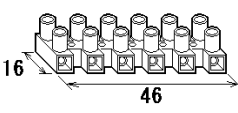
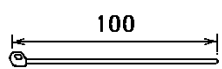
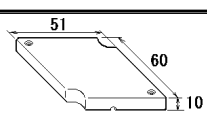
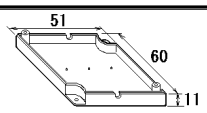
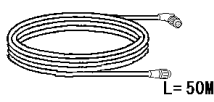
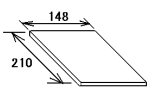
工事材料表		INSTRUMENT		FOR WIND	
INSTALLATION MATERIALS		FI-501		FI-501-50	
番号 NO.	名称 NAME	略図 OUTLINE	型名/規格 DESCRIPTIONS	数量 Q'TY	用途/備考 REMARKS
1	+トラスタップ [®] ネジ [®] 1シユ SELF-TAPPING SCREW		3X12 SUS304	4	
			CODE NO. 000-167-824-10		
2	ターミナル TERMINAL		4E/6	1	
			CODE NO. 000-168-024-10		
3	コンベックス CABLE TIE		CV-100N	4	
			CODE NO. 000-162-167-10		
4	中継箱カバー COVER		MO3-9372	1	
			CODE NO. 000-167-985-10		
5	中継箱ボディ BODY		MO3-9373	1	
			CODE NO. 000-167-986-10		
6	ケーブル組品 CABLE ASSY.		FI-50-SENSOR-50M	1	
			CODE NO. 000-166-947-11		
7	装備要領書 INSTALLATION MANUAL		IMC-72661-* 7/エ1	1	
			CODE NO. 000-167-285-1*		

型式/コード番号が2段の場合、下段より上段に代わる過渡期品であり、どちらかが入っています。なお、品質は変わりません。

TWO TYPES AND CODES MAY BE LISTED FOR AN ITEM. THE LOWER PRODUCT MAY BE SHIPPED IN PLACE OF THE UPPER PRODUCT. QUALITY IS THE SAME.

(略図の寸法は、参考値です。 DIMENSIONS IN DRAWING FOR REFERENCE ONLY.)



FURUNO ELECTRIC CO., LTD.

C7266-MO3-B

PACKING LIST FI-502

26AA-X-9858-3

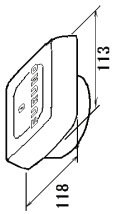
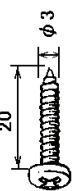
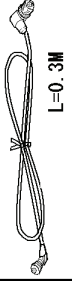
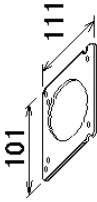
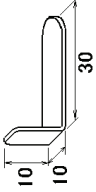
1/1

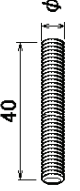
NAME	OUTLINE	DESCRIPTION/CODE No.	Q'TY
ユニット UNIT			
表示部 MONITOR UNIT		FI-502 000-011-741-00	1
工事材料 INSTALLATION MATERIALS CP26-00500			
ナハッピン 1シユ SELF-TAPPING SCREW		3X20 SUS304 000-163-884-10	4
ケーブル組品0.3M CABLE ASSEMBLY 0.3M		FI-50-CHAIN-0.3M 001-105-820-10	1
サフエスタウトスポンジ SPONGE		TZ7583002A0 000-167-832-10	1
パネルリムーバ PANEL REMOVER		19-028-3124-1 100-340-471-10	1
バネ座金 SPRING WASHER		M3 SUS304 000-167-404-10	2
ミカキ丸平座金 FLAT WASHER		M3 SUS304 000-167-453-10	2
寸切ボルト BOLT		M3X40 SUS304 000-167-804-10	2

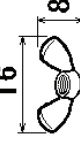
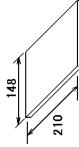
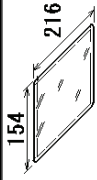
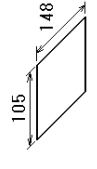
NAME	OUTLINE	DESCRIPTION/CODE No.	Q'TY
蝶ナット WING NUT		M3 SUS304 000-167-826-10	2
図書 DOCUMENT			
取扱説明書 OPERATOR'S MANUAL		OME-72660-* 000-166-982-1*	1
操作要領書 OPERATOR'S GUIDE		OS*-72660-* 000-167-289-1*	1
内部終端/設定 INTERNAL RESISTOR SETTING		C72-00705-* 000-168-501-1*	1

コード番号末尾の「**」は、選択品の代表コードを表します。

CODE NUMBER ENDING WITH "**" INDICATES THE CODE NUMBER OF REPRESENTATIVE MATERIAL.

型式/コード番号が2段の場合、下段より上段に代わる過渡期品であり、どちらかが入っています。なお、品質は変わりません。



TWO TYPES AND CODES MAY BE LISTED FOR AN ITEM. THE LOWER PRODUCT MAY BE SHIPPED IN PLACE OF THE UPPER PRODUCT. QUALITY IS THE SAME.

(略図の寸法は、参考値です。DIMENSIONS IN DRAWING FOR REFERENCE ONLY.)

PACKING LIST FI-505

26AA-X-9861-3

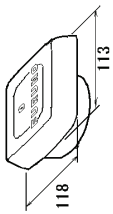
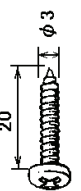
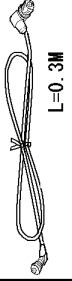
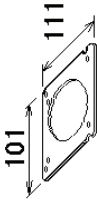
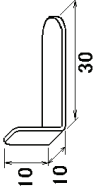
1/1

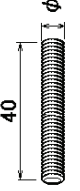
NAME	OUTLINE	DESCRIPTION/CODE No.	Q'TY
ユニット UNIT			
表示部 MONITOR UNIT		FI-505 000-011-746-00	1
工事材料 INSTALLATION MATERIALS CP26-00500			
ナハッピン 1シユ SELF-TAPPING SCREW		3X20 SUS304 000-163-884-10	4
ケーブル組品 0.3M CABLE ASSEMBLY 0.3M		FI-50-CHAIN-0.3M 001-105-820-10	1
サフエスタウトスポンジ SPONGE		TZ7583002A0 000-167-832-10	1
パネルリムーバ PANEL REMOVER		19-028-3124-1 100-340-471-10	1
バネ座金 SPRING WASHER		M3 SUS304 000-167-404-10	2
ミカキ丸平座金 FLAT WASHER		M3 SUS304 000-167-453-10	2
寸切ボルト BOLT		M3X40 SUS304 000-167-804-10	2

コード番号末尾の「**」は、選択品の代表コードを表します。

CODE NUMBER ENDING WITH "**" INDICATES THE CODE NUMBER OF REPRESENTATIVE MATERIAL.

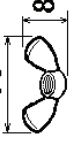
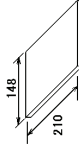
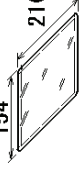
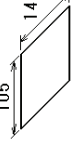
NAME	OUTLINE	DESCRIPTION/CODE No.	Q'TY
蝶ナット WING NUT		M3 SUS304 000-167-826-10	2
図書 DOCUMENT			
取扱説明書 OPERATOR'S MANUAL		OME-72660-* 000-166-982-1*	1
操作要領書 OPERATOR'S GUIDE		OS*-72700-* 000-167-292-1*	1
内部終端/設定 INTERNAL RESISTOR SETTING		C72-00705-* 000-168-501-1*	1

A-7

型式/コード番号が2段の場合、下段より上段に代わる過渡期品であり、どちらかが入っています。なお、品質は変わりません。
TWO TYPES AND CODES MAY BE LISTED FOR AN ITEM. THE LOWER PRODUCT MAY BE SHIPPED IN PLACE OF THE UPPER PRODUCT. QUALITY IS THE SAME.



(略図の寸法は、参考値です。DIMENSIONS IN DRAWING FOR REFERENCE ONLY.)

C7270-Z01-C

PACKING LIST FI-506

26AA-X-9862-3

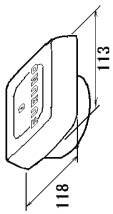
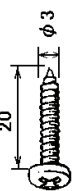
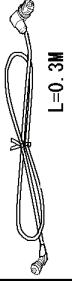
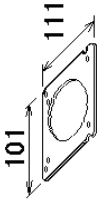
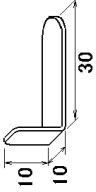
1/1

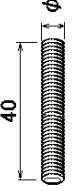
NAME	OUTLINE	DESCRIPTION/CODE No.	Q'TY
ユニット UNIT			
表示部 MONITOR UNIT		FI-506 000-011-747-00	1
工事材料 INSTALLATION MATERIALS CP26-00500			
ナハッピン 1シユ SELF-TAPPING SCREW		3X20 SUS304 000-163-884-10	4
ケーブル組品 0.3M CABLE ASSEMBLY 0.3M		FI-50-CHAIN-0.3M 001-105-820-10	1
サフエスタウトスポンジ SPONGE		TZ7583002A0 000-167-832-10	1
パネルリムーバ PANEL REMOVER		19-028-3124-1 100-340-471-10	1
バネ座金 SPRING WASHER		M3 SUS304 000-167-404-10	2
ミカキ丸平座金 FLAT WASHER		M3 SUS304 000-167-453-10	2
寸切ボルト BOLT		M3X40 SUS304 000-167-804-10	2

コード番号末尾の「**」は、選択品の代表コードを表します。

CODE NUMBER ENDING WITH "**" INDICATES THE CODE NUMBER OF REPRESENTATIVE MATERIAL.

78

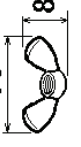
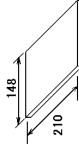
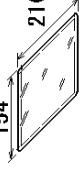
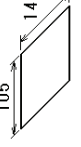

NAME	OUTLINE	DESCRIPTION/CODE No.	Q'TY
蝶ナット WING NUT		M3 SUS304 000-167-826-10	2
図書 DOCUMENT			
取扱説明書 OPERATOR'S MANUAL		OME-72660-* 000-166-982-1*	1
操作要領書 OPERATOR'S GUIDE		OS*-72710-* 000-167-293-1*	1
内部終端/設定 INTERNAL RESISTOR SETTING		C72-00705-* 000-168-501-1*	1

型式/コード番号が2段の場合、下段より上段に代わる過渡期品であり、どちらかが入っています。なお、品質は変わりません。
TWO TYPES AND CODES MAY BE LISTED FOR AN ITEM. THE LOWER PRODUCT MAY BE SHIPPED IN PLACE OF THE UPPER PRODUCT. QUALITY IS THE SAME.

(略図の寸法は、参考値です。DIMENSIONS IN DRAWING FOR REFERENCE ONLY.)

C7271-Z01-C

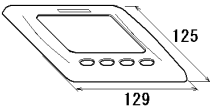
FURUNO

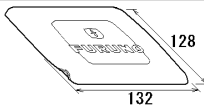
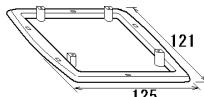
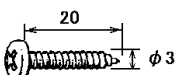
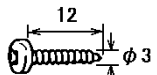
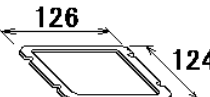
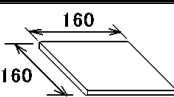
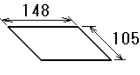
		CODE NO.	000-010-619-00	26AA-X-9401 -4	
		TYPE	FI-50-FLUSH-KIT	1/1	
フラッシュマウントキット FLUSH MOUNT KIT.		INSTRUMENTS FI-50			
番号 NO.	名称 NAME	略図 OUTLINE	型名/規格 DESCRIPTIONS	数量 Q'TY	用途/備考 REMARKS
1	前面パネル FRONT PANEL		TZ7580002A0	1	※1
			CODE NO. 000-167-885-10		
2	FURUNOロゴ H3 FURUNO STICKER H3		19-028-1502-0	1	※1に貼付済み PRE-ATTACHED TO ※1.
			CODE NO. 100-339-580-10		
3	ハードカバー-F COVER		TZ7580007A0	1	
			CODE NO. 000-167-887-10		
4	フラッシュマウントツール FRAME		TZ7580008A0	1	
			CODE NO. 000-167-886-10		
5	+ナベタッピンネジ 1シユ SELF-TAPPING SCREW		3X20 SUS304	4	
			CODE NO. 000-163-884-10		
6	+ナベPタイトネジ PAN HEAD P-TIGHT SCREW		3X12 SUS304	4	
			CODE NO. 000-167-827-10		
7	Fマウントスポンジ SPONGE		TZ7583001A0	1	
			CODE NO. 000-167-833-10		
8	取付要領書 INSTALLATION PROCEDURE		C72-00703-* 7/11	1	
			CODE NO. 000-167-323-1*		
9	ハードカバー-ハズシカタ HARD COVER DETACHMENT GUIDE		C72-00804-*	1	
			CODE NO. 000-170-074-1*		

型式/コード番号が2段の場合、下段より上段に代わる過渡期品であり、どちらかが入っています。なお、品質は変わりません。

TWO TYPES AND CODES MAY BE LISTED FOR AN ITEM. THE LOWER PRODUCT MAY BE SHIPPED IN PLACE OF THE UPPER PRODUCT. QUALITY IS THE SAME.

(略図の寸法は、参考値です。 DIMENSIONS IN DRAWING FOR REFERENCE ONLY.)

FURUNO ELECTRIC CO., LTD.

C7266-M01-C

表1 TABLE 1

寸法区分 (mm) DIMENSION	公差 (mm) TOLERANCE
L ≤ 50	±1.5
50 < L ≤ 100	±2.5
100 < L ≤ 500	±3

取付穴寸法図
CUTOUT DIMENSIONS

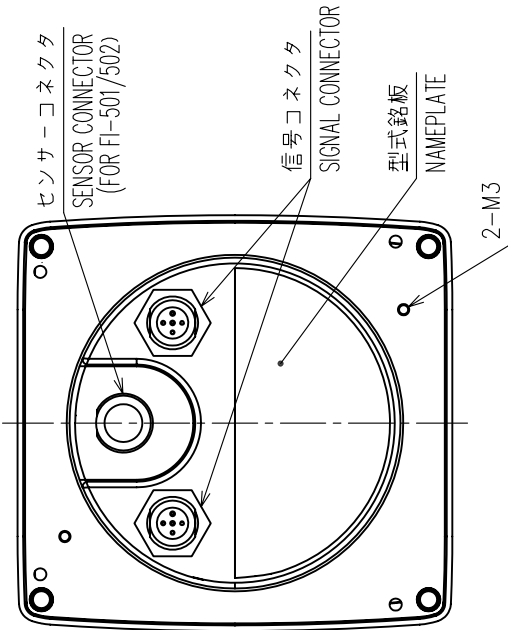
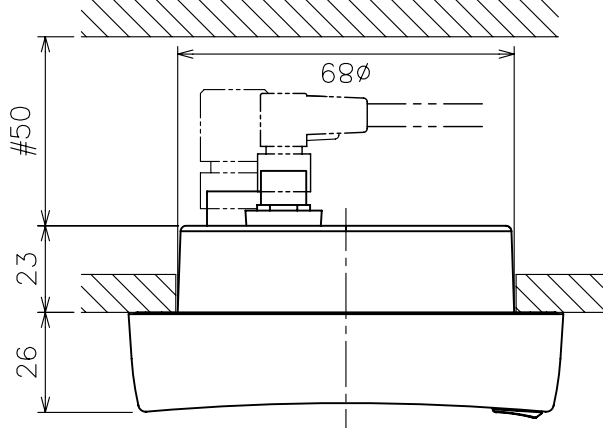
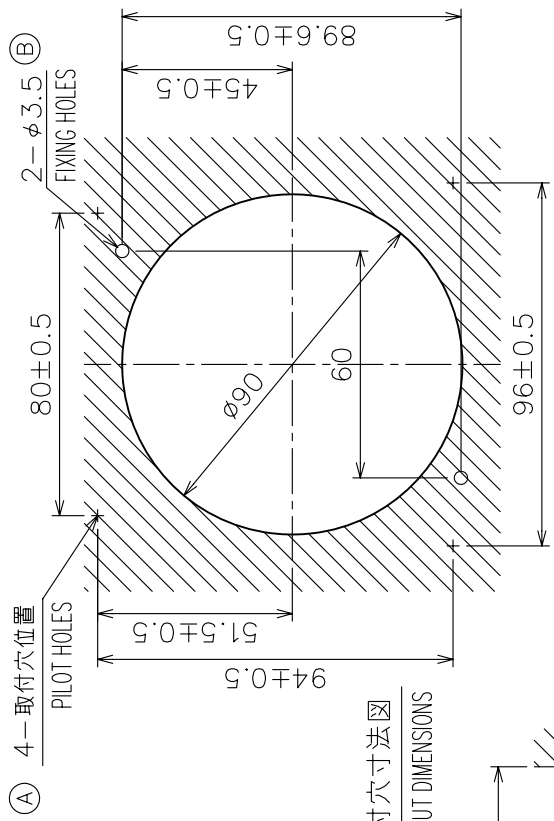

注記

- 指定外の寸法公差は表1による。
- #印寸法は最小サービスクリアランスとする。
- 取付方法は次の2種類から選択する。
 ㊶: ナベタッピンネジ呼び径3×20を使用のこと。
 ㊷: M3×40寸切りボルト、M3平座金/バネ座金/バネナットを使用のこと。

NOTE

- TABLE 1 INDICATES TOLERANCE OF DIMENSIONS WHICH IS NOT SPECIFIED.
- # MINIMUM SERVICE CLEARANCE.
- SELECT FIXING METHOD FROM FOLLOWINGS;
 ㊶ : USE TAPPING SCREWS $\phi 3 \times 20$.
 ㊷ : USE M3 STUD BOLT, P.W. / S.W. / WING NUT, SCREW LENGTH: 40.

DRAWN	30/Sep/09 I.YAMASAKI	TITLE	FI-501/502/503/504/505/506
CHECKED	30/Sep/09 I.TAKENO	名称	インストルメント (サーフェスマウント)
APPROVED	26/Oct/09 R. Esumi	外寸図	
SCALE	1/100 質量はケーブルを含まず。 MASS W/O CABLE.	NAME	INSTRUMENT (SURFACE MOUNT)
DWG.No.	C7266-G02-C	REF.No.	26-001-102G-2



表1 TABLE 1

寸法区分 (mm) DIMENSION	公差 (mm) TOLERANCE
L ≤ 50	±1.5
50 < L ≤ 100	±2.5
100 < L ≤ 500	±3

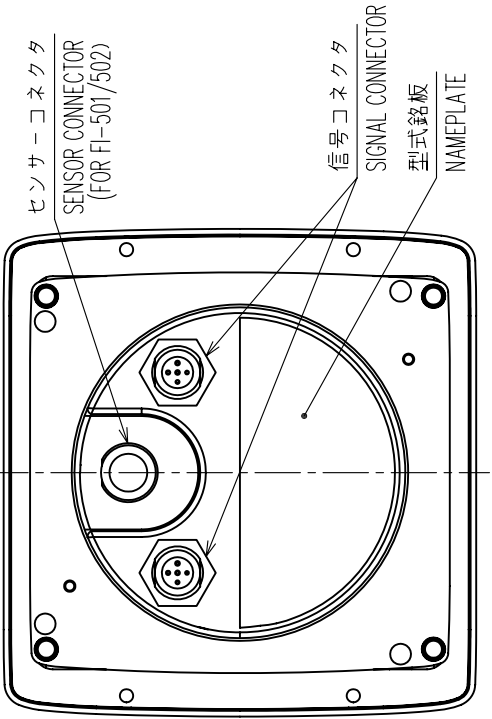
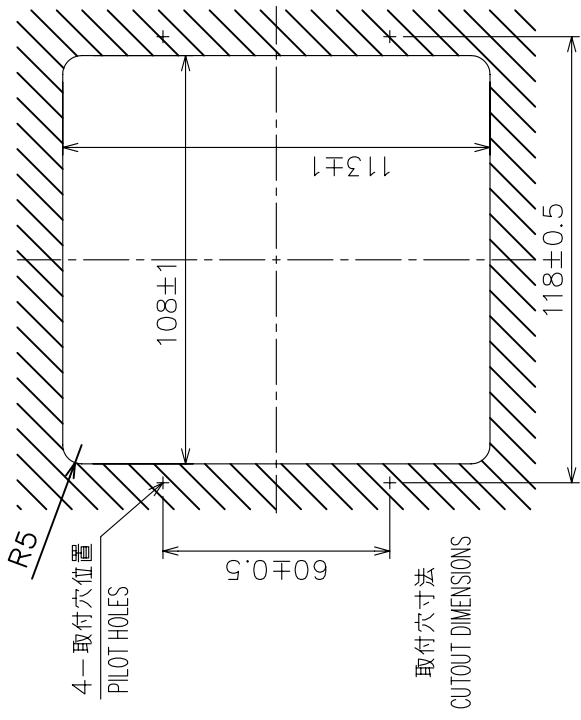
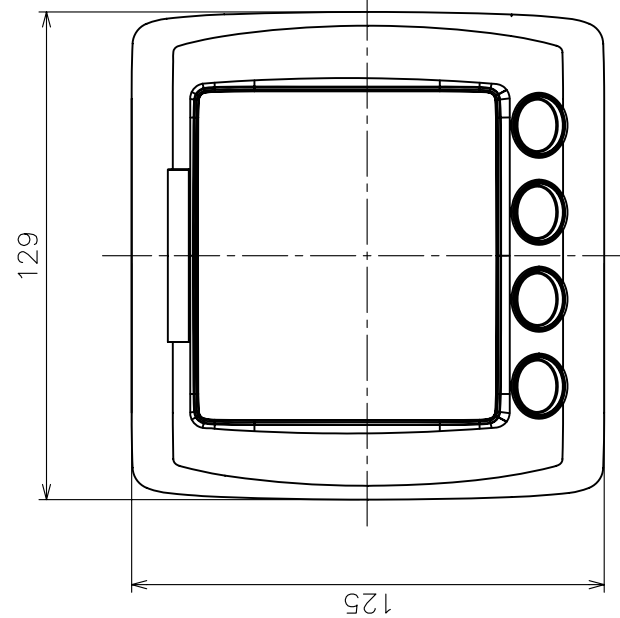
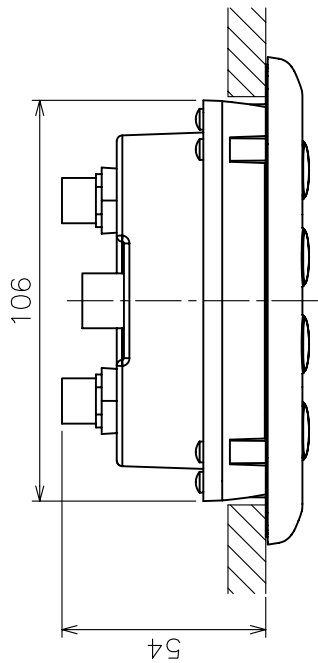
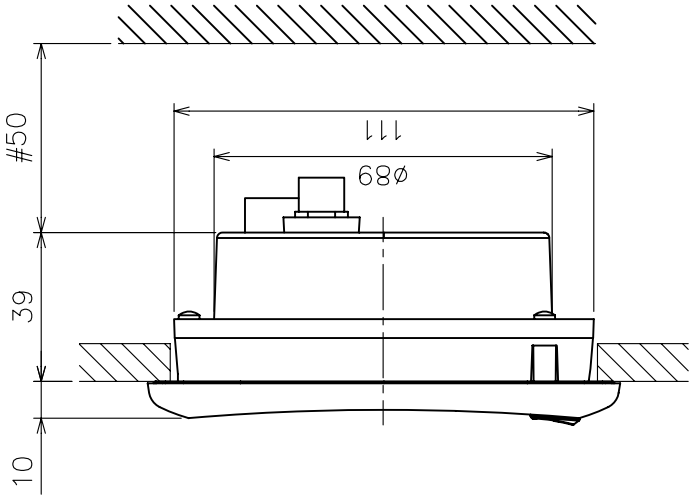

DRAWN	30/Sep/09 I. YAMASAKI	TITLE	FI-501/502/503/504/505/506
CHECKED	30/Sep/09 I. TAKENO	名#	インストルメント (フラッシュマウント)
APPROVED	26/Oct/09 R. Esumi	外寸図	
SCALE	MASS 0.3 ±10% kg	NAME	INSTRUMENT (FLUSH MOUNT)
DWG.No.	C7266-G01-B	REF.No.	26-001-101G-0

注 記

- 1) 指定外の寸法公差は表1による。
 - 2) 取付用ネジはナベタツ呼び径3×20を使用のこと。
- NOTE
1. TABLE 1 INDICATES TOLERANCE OF DIMENSIONS WHICH IS NOT SPECIFIED.
 2. USE TAPPING SCREWS $\phi 3 \times 20$ FOR FIXING THE UNIT.

表1 TABLE 1

寸法区分 (mm) DIMENSION	公差 (mm) TOLERANCE
$L \leq 50$	± 1.5
$50 < L \leq 100$	± 2.5
$100 < L \leq 500$	± 3
$500 < L \leq 1000$	± 4

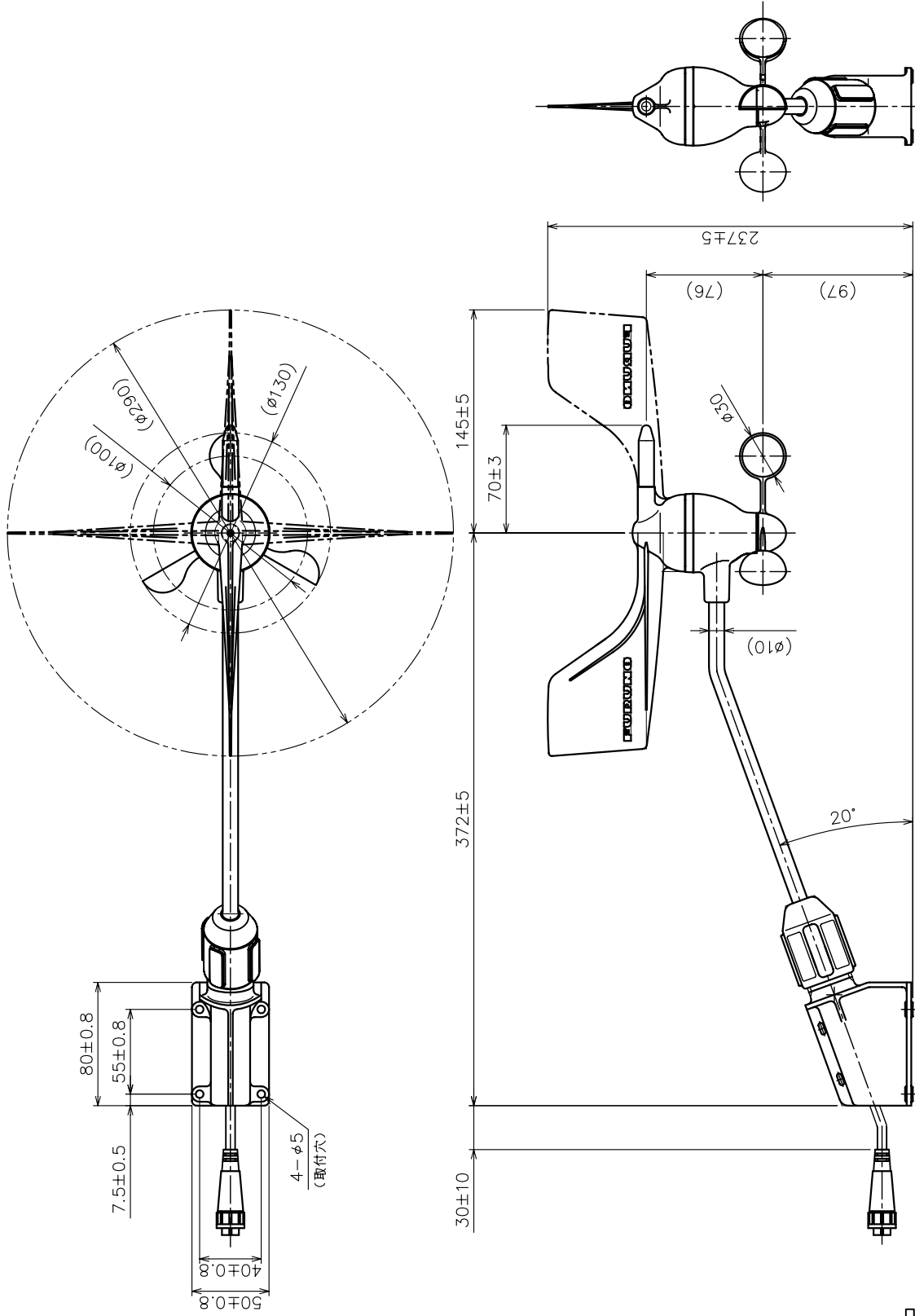

注記

- 1) 指定外の寸法公差は表1による。
- 2) 取付用ネジはトラスネジ呼び径4×20を使用のこと。

NOTE

1. TABLE 1 INDICATES TOLERANCE OF DIMENSIONS WHICH IS NOT SPECIFIED.
2. USE TAPPING SCREWS $\phi 4 \times 20$ FOR FIXING THE UNIT.

DRAWN	Sep. 14 '07 T. YAMASAKI	TITLE	FI-5001
CHECKED	Sep. 14 '07 T. TAKENO	名称	風向風速センサー
APPROVED	Sep. 21 '07 R. Esumi	外寸図	
SCALE	1/100	NAME	WIND TRANSDUCER
DWG. No.	C7266-G03-B	REF. No.	26-001-100G-2
			OUTLINE DRAWING

表1 TABLE 1

寸法区分 (mm) DIMENSION	公差 (mm) TOLERANCE
L ≤ 50	±1.5
50 < L ≤ 100	±2.5
100 < L ≤ 500	±3

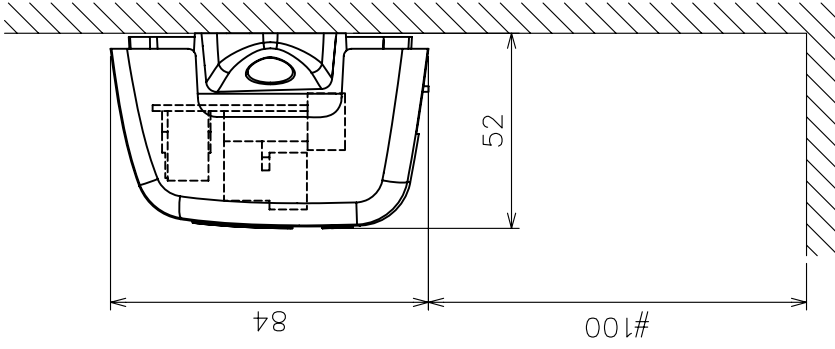
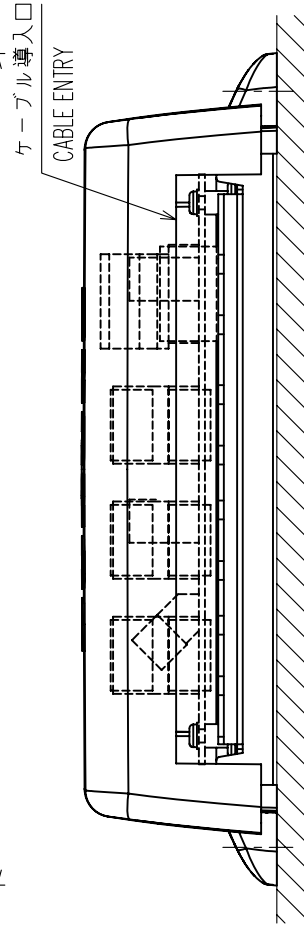
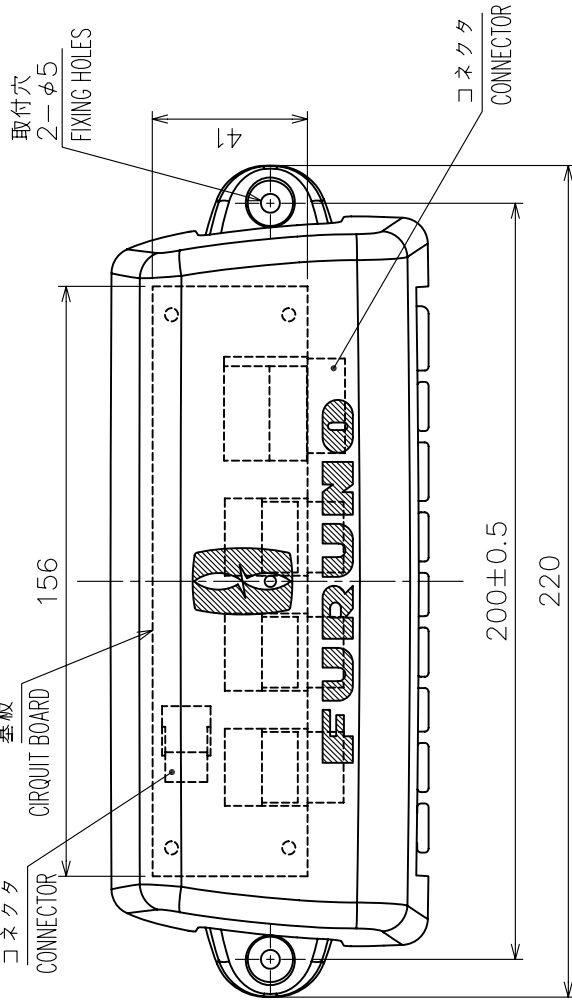

注 記

- 1) #印寸法は最小サービス空間寸法とする。
- 2) 指定外の寸法公差は表1による。
- 3) 取付用ネジはトラスタッピョンネジ呼び径4×20を使用のこと。

NOTE

1. # MINIMUM SERVICE CLEARANCE.
2. TABLE 1 INDICATES TOLERANCE OF DIMENSIONS WHICH IS NOT SPECIFIED.
3. USE TAPPING SCREWS $\phi 4 \times 20$ FOR FIXING THE UNIT.

DRAWN	Jul. 19 '07	T. YAMASAKI	TITLE	FI-5002
CHECKED	Jul. 19 '07	T. TAKENO	名#	ジャンクションボックス
APPROVED	Jul. 24 '07	R. Esumi	外寸図	
SCALE	1/100	0.3 kg	NAME	JUNCTION BOX
DWG.No.	C7268-G01-A	REF.No.	26-001-103G-0	OUTLINE DRAWING

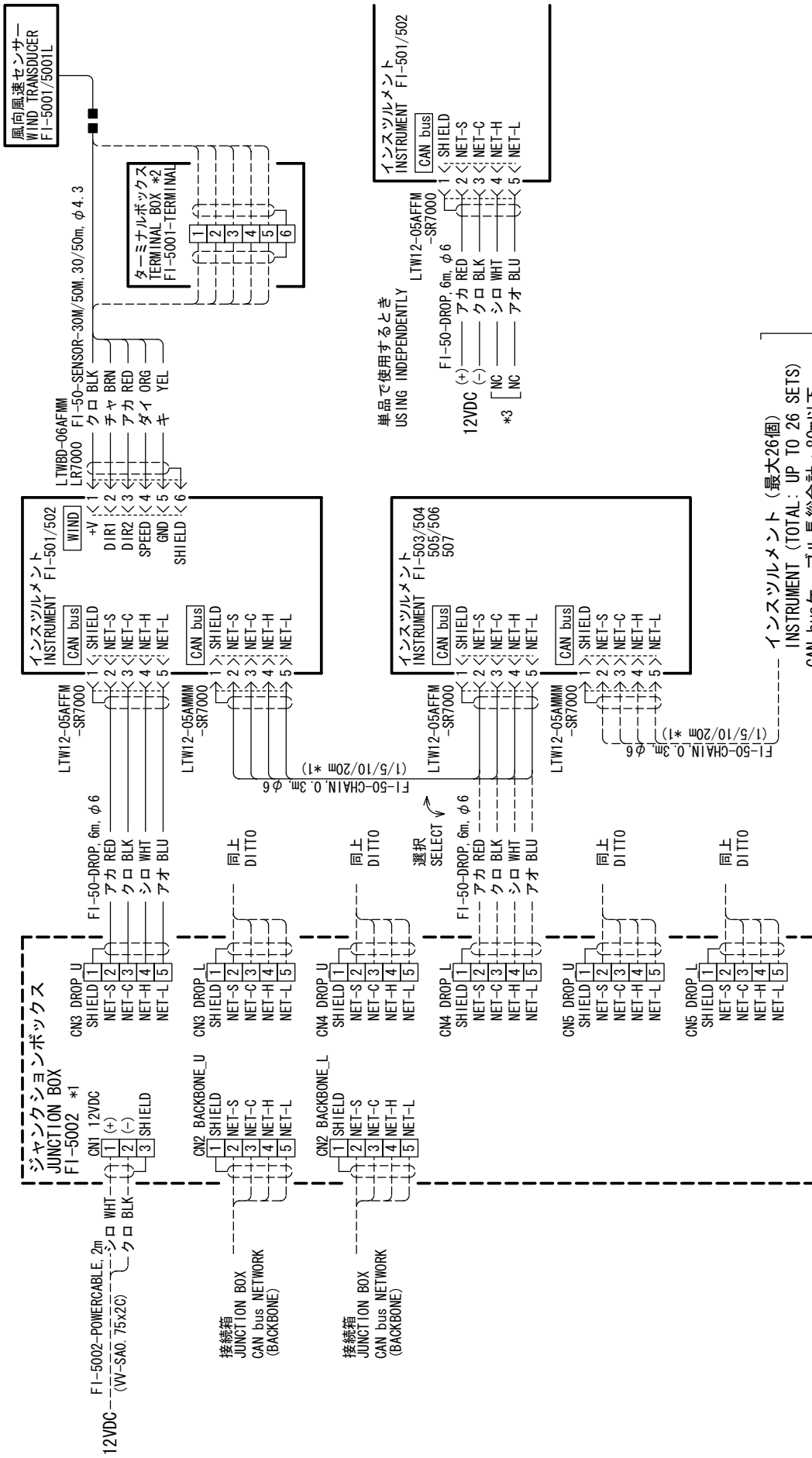

注記 * 1) オプション。
 * 2) ケーブルを切断する場合は、ターミナルボックス（非防水）を使用のこと。
 * 3) 短絡しないように、端末を処理する。

インストゥルメント (最大26個)
 INSTRUMENT (TOTAL: UP TO 26 SETS)
 CAN busケーブル長総合計: 80m以下
 CAN bus CABLE TOTAL LENGTH: UP TO 80m

単品で使用するとき
 USING INDEPENDENTLY

インストゥルメント
 INSTRUMENT FI-501/502

LTW12-05AFFM -SR7000

FI-50-DROP, 6m, φ6

12VDC (+) アカ RED
 (-) クロ BLK
 *3 [NC シロ WHT
 [NC アオ BLU

DRAWN	28/Jan/10	T. YAMASAKI	TITLE	FI-501/502/503/504/505/506/507
CHECKED	28/Jan/10	T. TAKENO	名称	インストゥルメント
APPROVED	8/Mar/10	R. Esumi	相互結線図	
SCALE	MASS	kg	INSTRUMENT	
DWG. No.	C7266-C01-J	REF. No.	INTERCONNECTION DIAGRAM	

NOTE
 *1: OPTION
 *2: USE A TERMINAL BOX (NO-PROTECTION) WHEN THE SUPPLIED CABLE IS CUT.
 *3: PROTECT CABLE ENDS TO PREVENT SHORT-CIRCUIT.

FURUNO Worldwide Warranty for Pleasure Boats (Except North America)

This warranty is valid for products manufactured by Furuno Electric Co. (hereafter FURUNO) and installed on a pleasure boat. Any web based purchases that are imported into other countries by anyone other than a FURUNO certified dealer may not comply with local standards. FURUNO strongly recommends against importing these products from international websites as the imported product may not work correctly and may interfere with other electronic devices. The imported product may also be in breach of the local laws and mandated technical requirements. Products imported into other countries as described previously shall not be eligible for local warranty service.

For products purchased outside of your country please contact the national distributor of Furuno products in the country where purchased.

This warranty is in addition to the customer's statutory legal rights.

1. Terms and Conditions of Warranty

FURUNO guarantees that each new FURUNO product is the result of quality materials and workmanship. The warranty is valid for a period of 2 years (24 months) from the date of the invoice, or the date of commissioning of the product by the installing certified dealer.

2. FURUNO Standard Warranty

The FURUNO standard warranty covers spare parts and labour costs associated with a warranty claim, provided that the product is returned to a FURUNO national distributor by prepaid carrier.

The FURUNO standard warranty includes:

- Repair at a FURUNO national distributor
- All spare parts for the repair
- Cost for economical shipment to customer

3. FURUNO Onboard Warranty

If the product was installed/commissioned and registered by a certified FURUNO dealer, the customer has the right to the onboard warranty.

The FURUNO onboard warranty includes

- Free shipping of the necessary parts
- Labour: Normal working hours only
- Travel time: Up to a maximum of two (2) hours
- Travel distance: Up to a maximum of one hundred and sixty (160) KM by car for the complete journey

4. Warranty Registration

For the Standard Warranty - presentation of product with serial number (8 digits serial number, 1234-5678) is sufficient. Otherwise, the invoice with serial number, name and stamp of the dealer and date of purchase is shown.

For the Onboard Warranty your FURUNO certified dealer will take care of all registrations.

5. Warranty Claims

For the Standard Warranty - simply send the defective product together with the invoice to a FURUNO national distributor. For the Onboard Warranty – contact a FURUNO national distributor or a certified dealer. Give the product's serial number and describe the problem as accurately as possible.

Warranty repairs carried out by companies/persons other than a FURUNO national distributor or a certified dealer is not covered by this warranty.

6. Warranty Limitations

When a claim is made, FURUNO has a right to choose whether to repair the product or replace it.

The FURUNO warranty is only valid if the product was correctly installed and used. Therefore, it is necessary for the customer to comply with the instructions in the handbook. Problems which result from not complying with the instruction manual are not covered by the warranty.

FURUNO is not liable for any damage caused to the vessel by using a FURUNO product.

The following are excluded from this warranty:

- a. Second-hand product
- b. Underwater unit such as transducer and hull unit
- c. Routine maintenance, alignment and calibration services.
- d. Replacement of consumable parts such as fuses, lamps, recording papers, drive belts, cables, protective covers and batteries.
- d. Magnetron and MIC with more than 1000 transmitting hours or older than 12 months, whichever comes first.
- e. Costs associated with the replacement of a transducer (e.g. Crane, docking or diver etc.).
- f. Sea trial, test and evaluation or other demonstrations.
- g. Products repaired or altered by anyone other than the FURUNO national distributor or an authorized dealer.
- h. Products on which the serial number is altered, defaced or removed.
- i. Problems resulting from an accident, negligence, misuse, improper installation, vandalism or water penetration.
- j. Damage resulting from a force majeure or other natural catastrophe or calamity.
- k. Damage from shipping or transit.
- l. Software updates, except when deemed necessary and warrantable by FURUNO.
- m. Overtime, extra labour outside of normal hours such as weekend/holiday, and travel costs above the 160 KM allowance
- n. Operator familiarization and orientation.

FURUNO Electric Company, March 1, 2011

FURUNO Warranty for North America

FURUNO U.S.A., Limited Warranty provides a twenty-four (24) months LABOR and twenty-four (24) months PARTS warranty on products from the date of installation or purchase by the original owner. Products or components that are represented as being waterproof are guaranteed to be waterproof only for, and within the limits, of the warranty period stated above. The warranty start date may not exceed eighteen (18) months from the original date of purchase by dealer from Furuno USA and applies to new equipment installed and operated in accordance with Furuno USA's published instructions.

Magnetrons and Microwave devices will be warranted for a period of 12 months from date of original equipment installation.

Furuno U.S.A., Inc. warrants each new product to be of sound material and workmanship and through its authorized dealer will exchange any parts proven to be defective in material or workmanship under normal use at no charge for a period of 24 months from the date of installation or purchase.

Furuno U.S.A., Inc., through an authorized Furuno dealer will provide labor at no cost to replace defective parts, exclusive of routine maintenance or normal adjustments, for a period of 24 months from installation date provided the work is done by Furuno U.S.A., Inc. or an AUTHORIZED Furuno dealer during normal shop hours and within a radius of 50 miles of the shop location.

A suitable proof of purchase showing date of purchase, or installation certification must be available to Furuno U.S.A., Inc., or its authorized dealer at the time of request for warranty service.

This warranty is valid for installation of products manufactured by Furuno Electric Co. (hereafter FURUNO). Any purchases from brick and mortar or web-based resellers that are imported into other countries by anyone other than a FURUNO certified dealer, agent or subsidiary may not comply with local standards. FURUNO strongly recommends against importing these products from international websites or other resellers, as the imported product may not work correctly and may interfere with other electronic devices. The imported product may also be in breach of the local laws and mandated technical requirements. Products imported into other countries, as described previously, shall not be eligible for local warranty service.

For products purchased outside of your country please contact the national distributor of Furuno products in the country where purchased.

WARRANTY REGISTRATION AND INFORMATION

To register your product for warranty, as well as see the complete warranty guidelines and limitations, please visit www.furunousa.com and click on "Support". In order to expedite repairs, warranty service on Furuno equipment is provided through its authorized dealer network. If this is not possible or practical, please contact Furuno U.S.A., Inc. to arrange warranty service.

FURUNO U.S.A., INC.
Attention: Service Coordinator
4400 N.W. Pacific Rim Boulevard
Camas, WA 98607-9408
Telephone: (360) 834-9300
FAX: (360) 834-9400

Furuno U.S.A., Inc. is proud to supply you with the highest quality in Marine Electronics. We know you had several choices when making your selection of equipment, and from everyone at Furuno we thank you. Furuno takes great pride in customer service.

