

Installation Manual COLOR SOUNDER FCV-30

SAFETY INSTRUCTIONS	i
SYSTEM CONFIGURATION	iii
EQUIPMENT LISTS	iv
1. MOUNTING	1
1.1 Control Unit	1
1.2 Processor Unit	3
1.3 Transceiver Unit	4
1.4 Transducer	5
1.5 Junction Box	8
2. WIRING	9
2.1 Interconnection	9
2.2 Cable Fabrication	11
2.3 Synchronizing Transmission with Echo Sounder or Other Sonar	13
2.4 Input/Output Sentences	14
3. SYSTEM SETTINGS AFTER INSTALLATION	15
OUTLINE DRAWINGS	D-1
INTERCONNECTION DIAGRAM	S-1

ECF

(Elemental Chlorine Free)

The paper used in this manual
is elemental chlorine free.

FURUNO ELECTRIC CO., LTD.

9-52 Ashihara-cho,
Nishinomiya, 662-8580, JAPAN

Telephone : +81-(0)798-65-2111

Fax : +81-(0)798-65-4200

• FURUNO Authorized Distributor/Dealer

All rights reserved. Printed in Japan

Pub. No. IME-23730-F

(TOMA) FCV-30

A : FEB . 2005

F : APR . 20, 2010



* 0 0 0 1 5 1 8 3 7 1 5 *



SAFETY INSTRUCTIONS



WARNING



ELECTRICAL SHOCK HAZARD
Do not open the equipment unless totally familiar with electrical circuits and service manual.

Only qualified personnel should work inside the equipment.

Turn off the power at the switchboard before beginning the installation.

Fire or electrical shock can result if the power is left on.

Do not install the equipment where it may get wet from rain or water splash.

Water in the equipment can result in fire, electrical shock or equipment damage.

Be sure no water leaks in at the transducer mounting location.

Water leakage can sink the vessel. Also, confirm that the transducer will not loosen by ship's vibration. The installer of the equipment is solely responsible for the proper installation of the equipment. FURUNO will assume no responsibility for any damage associated with improper installation.

Be sure that the power supply is compatible with the voltage rating of the equipment.

Connection of an incorrect power supply can cause fire or equipment damage. The voltage rating of the equipment appears on the label above the power connector.





WARNING

Install the transducer according to the installation instructions.

Failure to install the transducer correctly may result in water leakage and damage to the ship's hull.

For wooden or FRP vessel using a steel tank, attach a zinc plate to the hull to prevent electrolytic corrosion.

Electrolytic corrosion can, in the worst case, result in loss of the transducer.

 <b style="font-size: 1.2em;">CAUTION		
<div style="display: flex; align-items: center;">  <p style="margin: 0;">Ground the equipment to prevent mutual interference.</p> </div>		
<p>Observe the following compass safe distances to prevent interference to a magnetic compass:</p>		
	Standard compass	Steering compass
CV-301	0.85 m	0.55 m
CV-302	1.55 m	0.95 m
CV-300	1.25 m	0.70 m
CV-304	1.10 m	0.70 m
<p>Do not allow warm water or any other liquid other than seawater or freshwater to contact the transducer.</p> <p>Damage to the transducer may result.</p>		
<p>Do not install the transducer where noise or air bubbles is present.</p> <p>Performance will be affected.</p>		

 <b style="font-size: 1.2em;">CAUTION
<p>The transducer cable must be handled carefully, following the guidelines below.</p> <ul style="list-style-type: none"> • Keep fuels and oils away from the cable. • Locate the cable where it will not be damaged. • The cable sheath is made of chlorophrene or polychloride vinyl, which are easily damaged by plastic solvents such as toluene. Locate the cable well away from plastic solvents.

SYSTEM CONFIGURATION

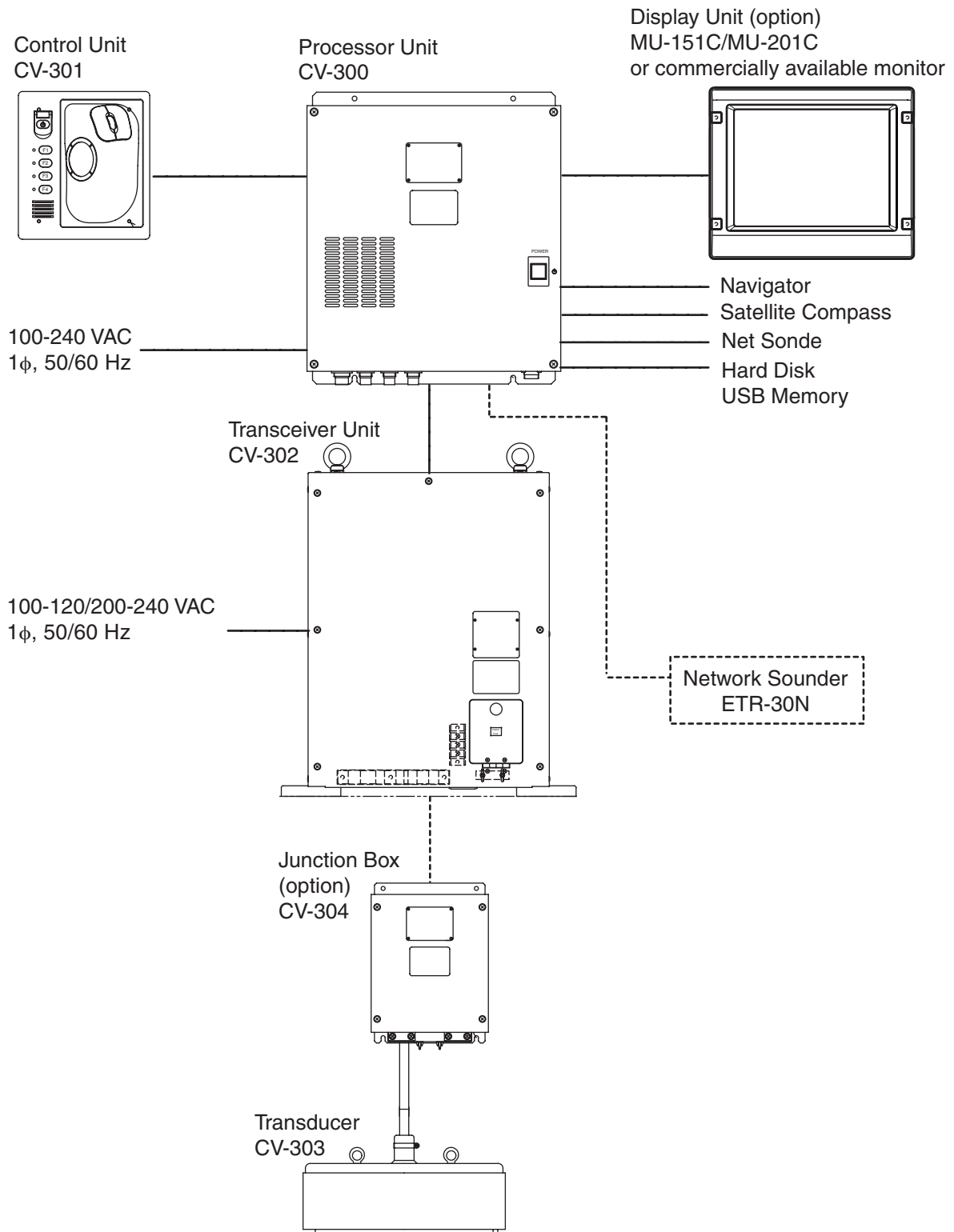

EQUIPMENT LISTS

Standard supply

Name	Type	Code No.	Qty	Remarks
Processor Unit	CV-300	–	1	With spare parts SP02-04801, SP02-05101 and installation materials CP06-01401
Control Unit	CV-301	–	1	With FP03-09860 & CP03-25604
Transceiver Unit	CV-302	–	1	With SP02-04901 & CP02-07801
	CV-302-MS			
Transducer	CV-303	–	1	
Thru-hull pipe	TFB-1600	000-012-539	1	
Installation Materials	CP03-28900	000-082-658	1 set	Connector CP03-28901 (MPS588-C: 000-166-044-10, 2 pcs) & cable FR-FTPC-CY *10m*
	CP03-28910	000-082-659		Connector CP03-28901 (MPS588-C: 000-148-322, 2 pcs) & cable FR-FTPC-CY *20m*
	CP03-28920	000-082-660		Connector CP03-28901 (MPS588-C: 000-148-322, 2 pcs) & cable FR-FTPC-CY *30m*

Installation Materials CP06-01401: 001-403-810

Name	Type	Code no.	Qty	Remarks
Connector	SRCN6A13-3S	000-160-725-10	1	For power line

Installation Materials CP03-25604: 008-539-850

Name	Type	Code no.	Qty	Remarks
Screw	M4x12	000-163-192-10	4	

Installation Materials CP02-07801: 001-416-080

Name	Type	Code no.	Qty	Remarks
Crimp-on lug	FV5.5-S4	000-166-750-10	3	

Spare parts SP02-05101: 001-416-060

Name	Type	Code no.	Qty	Remarks
Fuse	FGMB 250V 5A PBF	000-157-570-10	2	

Spare parts SP02-04901: 001-416-070

Name	Type	Code no.	Qty	Remarks
Fuse	FGMB 125V 10A PBF	000-157-470-10	2	
Fuse	FGMB 250V 5A PBF	000-157-570-10	2	

Accessories SP03-09860: 008-535-690

Name	Type	Code no.	Qty	Remarks
Cushion	TM-180-302	000-166-468-10	2	
Grommet	G-49	000-166-406-10	1	
Blind seal	22-020-1005-1	100-173-591-10	3	
KB fixing metal	03-163-7821-1	100-306-291-10	1	
Pan head screw	M4x12	000-163-192-10	2	

Optional equipment

Name	Type	Code No.	Qty	Remarks
Junction box	CV-304-10	000-012-540	1	With cable Z-FNH-SB 68XP26AWG, 10 m
	CV-304-20	000-012-541		With cable Z-FNH-SB 68XP26AWG, 20 m
Transducer tank	T-625	000-012-545	1	
Transducer Fixing plate kit	T-625-A	001-096-720	1	

1. MOUNTING

NOTICE

Do not apply paint, anti-corrosive sealant or contact spray to coating or plastic parts of the equipment.

Those items contain organic solvents that can damage coating and plastic parts, especially plastic connectors.

1.1 Control Unit

Mounting considerations

When selecting a mounting location, keep in mind the following points:

- Select a location where the control unit can be operated conveniently.
- Locate the unit away from heat sources because of heat that can build up inside the unit.
- Locate the equipment away from places subject to water splash and rain.
- Determine the mounting location considering the length of the signal cable between the control unit and the processor unit. (The length of the signal cable is 5 m.)
- Observe the compass safe distances on page ii to prevent deviation of a magnetic compass.

Fixing with KB fixing plate

1. Fix the KB fixing plate to the bottom of the control unit.
2. Attach cushions to the bottom of the control unit as shown below.
3. Fix it to a desired location with self-tapping screws (local supply).

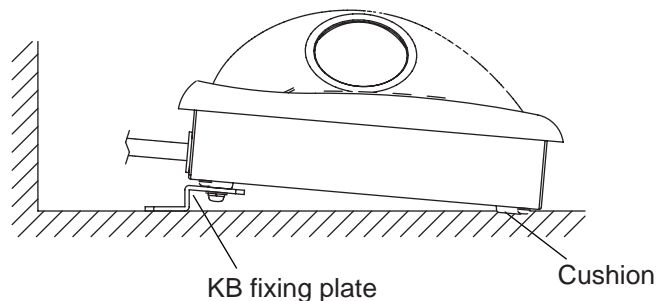

1. MOUNTING

Fixing without KB fixing metal

1. Drill four mounting holes of 5 mm diameter referring to the drawing below.
2. Fix the control unit with four screws (M4) from under side of the desktop. Use M4x12 (supplied) for mounting panel thickness "t" between 2 and 5 mm. For greater thickness, screw length shall be $M4x(t+7.8\pm 2)$.

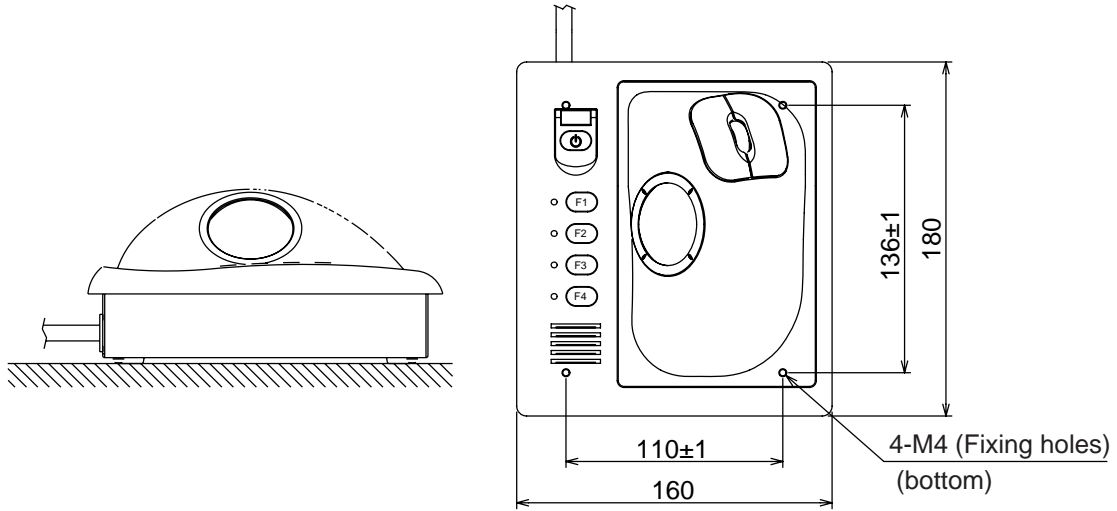

1.2 Processor Unit

The processor unit can be mounted on the deck, a desktop or on a bulkhead. Select a mounting location considering the points below.

- Locate the unit out of direct sunlight.
- Select a location where temperature and humidity are moderate and stable.
- Locate the unit where its cover can be easily removed and cabling easily accessed.
- For mounting on a bulkhead be sure the mounting location is strong enough to support the unit under the pitching and rolling normally encountered on the vessel.
- Leave sufficient space around the unit for maintenance and servicing. Recommended maintenance space “#” appears in the figure below.

Tabletop or deck mounting: Fasten with four tapping screws.

Bulkhead mounting: Screw in two tapping screws in mounting location for lower mounting holes of the unit, leaving 5 mm protruding. Set the processor unit to the screws, tighten screws and screw in two tapping screws for upper mounting holes of the unit.

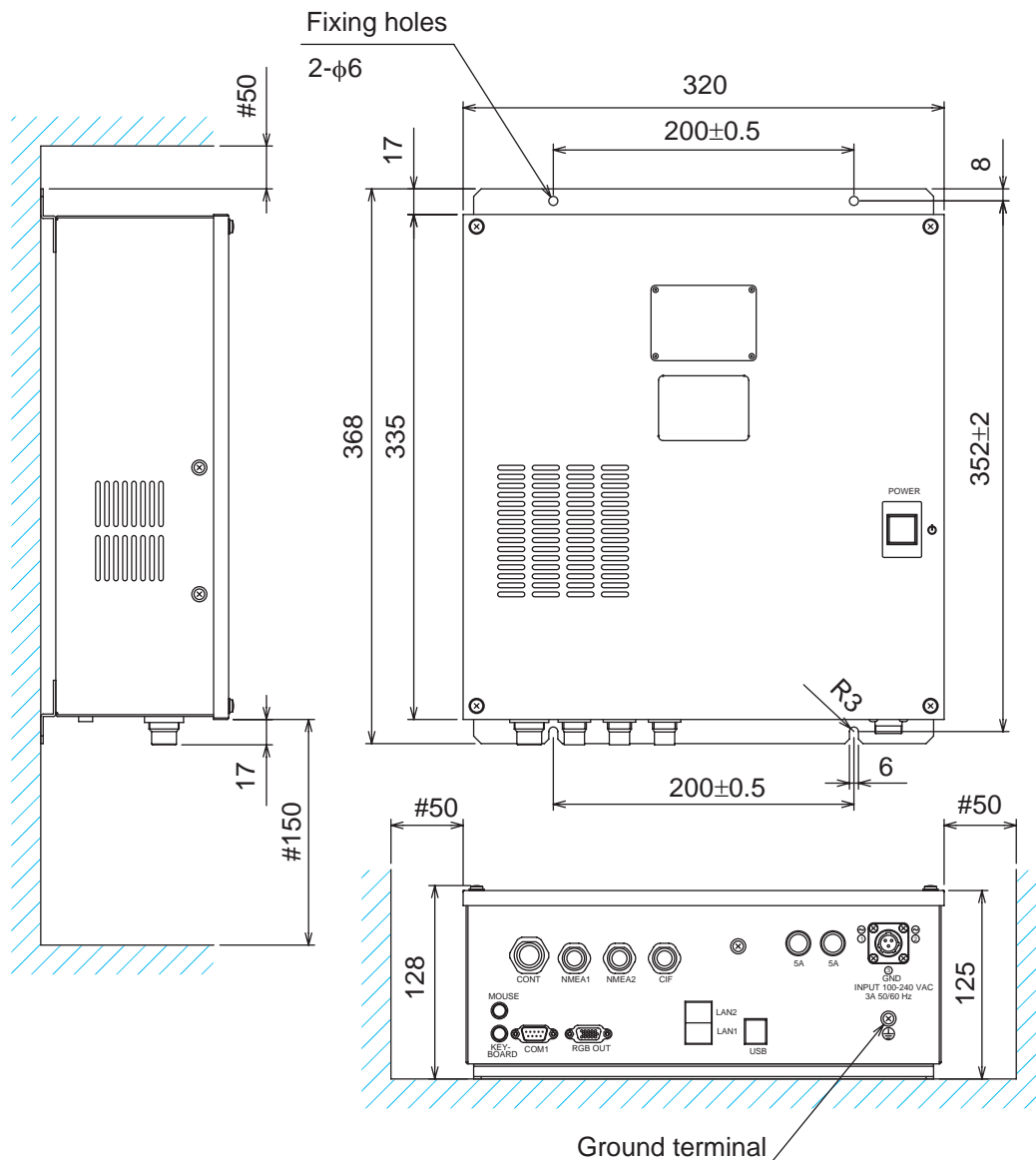

1.3 Transceiver Unit

The transceiver unit is designed to be mounted on the deck. Select a mounting location considering the points below.

- The transceiver unit generates heat so the mounting location should be well ventilated and dry.
- The unit is only designed for deck mounting.
- Secure the maintenance space “#” shown in the figure below for ease of maintenance and service.
- For the CV-302-MS (transceiver unit with motion sensor), install it horizontally in the location where the ambient temperature is lower than 45°C. If the front panel of the unit is oriented to port, its motion sensor faces the bow, i.e., the arrow mark of the NOTE label on the transceiver unit orients to bow. After installation, compensate for installation angle error, referring to chapter 3.

If necessary, install a channel base on the mounting location, consulting with the shipyard. Fasten the transceiver unit to the channel base with M12 bolts. If necessary, reinforce the transceiver unit against vibration by stays extending from the eyebolts.

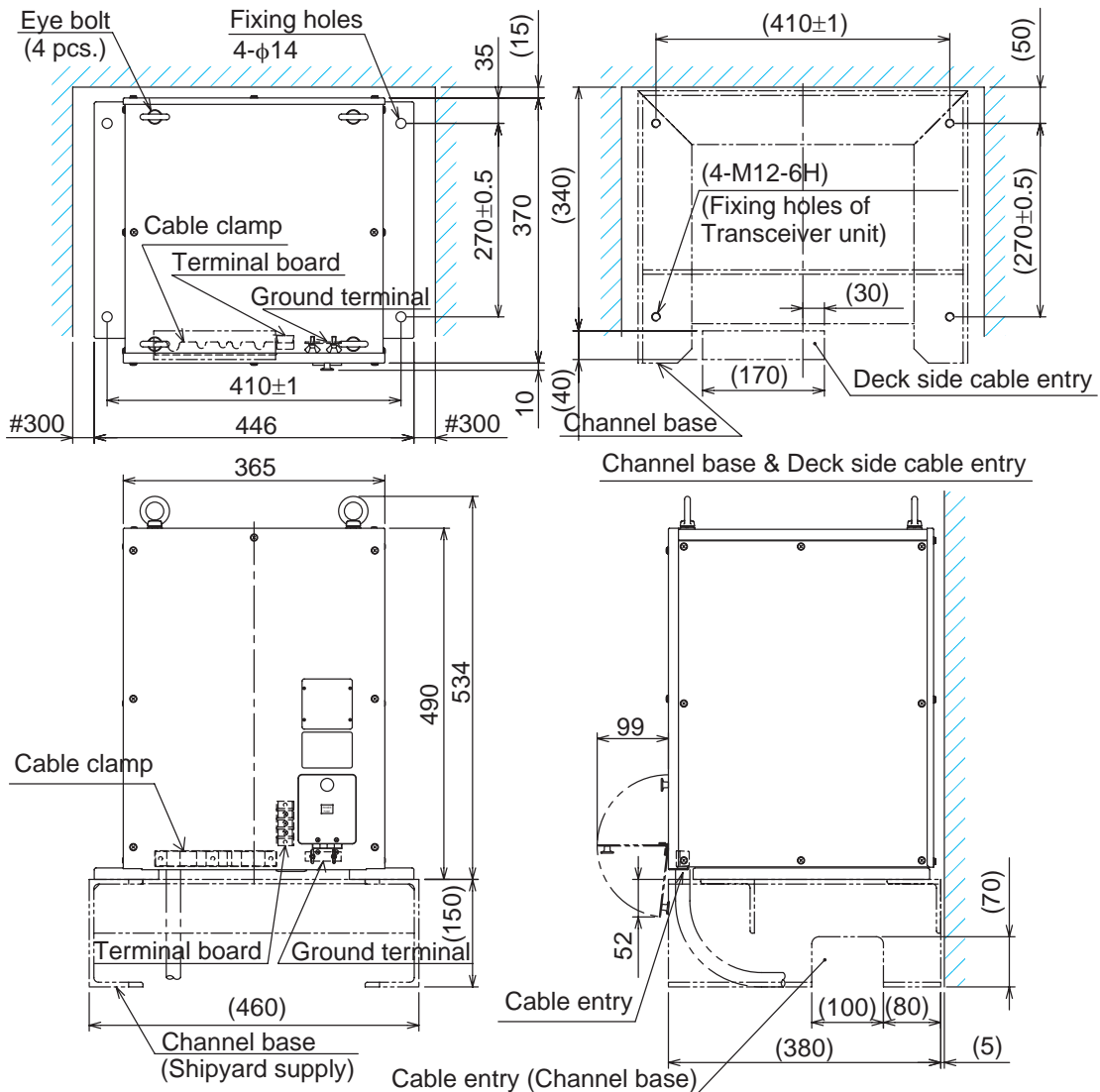

1.4 Transducer

The performance of the color sounder depends upon the transducer position.

- A place least affected by air bubbles should be selected since turbulence blocks the sounding path.
- Select a place not influenced by engine noise.
- Further, select a place not influenced by other electronic device.

Install the transducer on the hull, orienting it so the bow mark is facing the ship's bow.

Note: Carefully handle the transducer. Do not lift the transducer by holding the cable, nor drop it.

It is known that air bubbles are fewest at the place where the bow first falls and the next wave rises, at usual cruising speed. In small, slow-speed boats, the position between 1/3 and 1/2 of the ship's length from the bow is usually a good place. The face of the transducer must be facing the sea bottom in normal cruising trim of the boat.

Refer to the installation drawing for the transducer, combined with the thru-hull pipe TFB-1600 and optional transducer tank T-625.

About transducer casing

The FURUNO transducer tank is finished with lacquer primer to prevent corrosion in storage. After welding the casing to ship's hull, remove the lacquer primer, using lacquer thinner. Coat casing with same paint as used on ship's hull.

How to remove lacquer primer from the tank (Several methods)

1. Dissolve and remove paint with solvent.
2. Remove rust, coating, oil film, etc, with a blaster.
3. Remove with a disk sander or foil brush.

Transducer Fixing Plate Kit (optional) assembly

When using the optional T-625 transducer tank, you can use the optional T-625-A transducer fixing plate kit against expected noise of the ship movement.

Transducer Fixing Plate Kit T-625-A

Name	Type	Code Number	Quantity
Transducer fixing plate	T-625-A	001-096-730-00	1
Hose band	Action Band -450-SUS	000-173-035-10	2
Flank sponge	02-153-4322	100-357-760-10	2

1. MOUNTING

1. Remove the press plate from the transducer fixing plate and attach to the transducer.

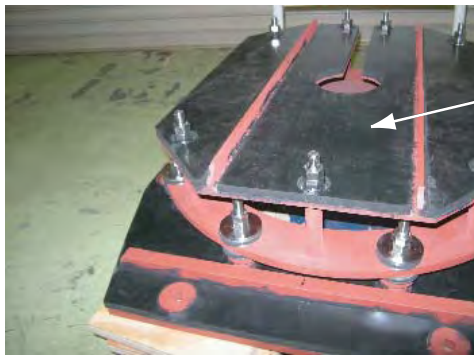

Press plate

Transducer fixing plate

Be careful of bow direction



Transducer

2. Wreathe the two flank sponges around the lateral sides of the transducer. Face the cut side toward the transducer and insert the uncut part between the transducer and the TD attachment.

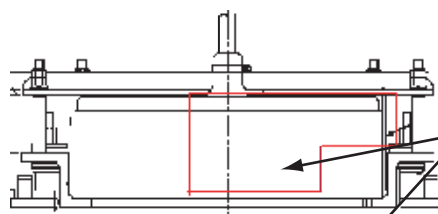

Flank sponge

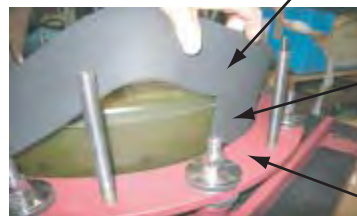

Insert the uncut part between the transducer and the TD attachment.

TD attachment

3. Attach the sponge with the hose band (stainless band). Apply silicone sealant (local supply) to the screws to prevent rusting and corrosion.

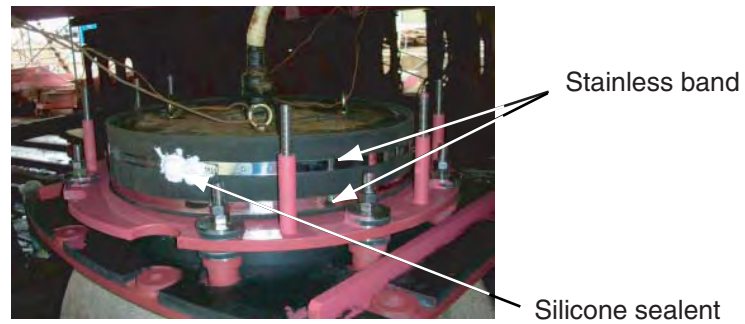

4. Replace the press plate as before. Tighten a double nut at 63.5Nm torque.



5. To attach to the ship's bottom, refer to the T625 tank drawing.

1.5 Junction Box (option)

If the length of cable between the transducer and transceiver unit is more than 15 m, the optional junction box (with 10 m or 20 m cable) can be used for cable extension.

For bulkhead mounting, orient the cable entry downside and fix the junction box with M5 bolts (shipyard supply).

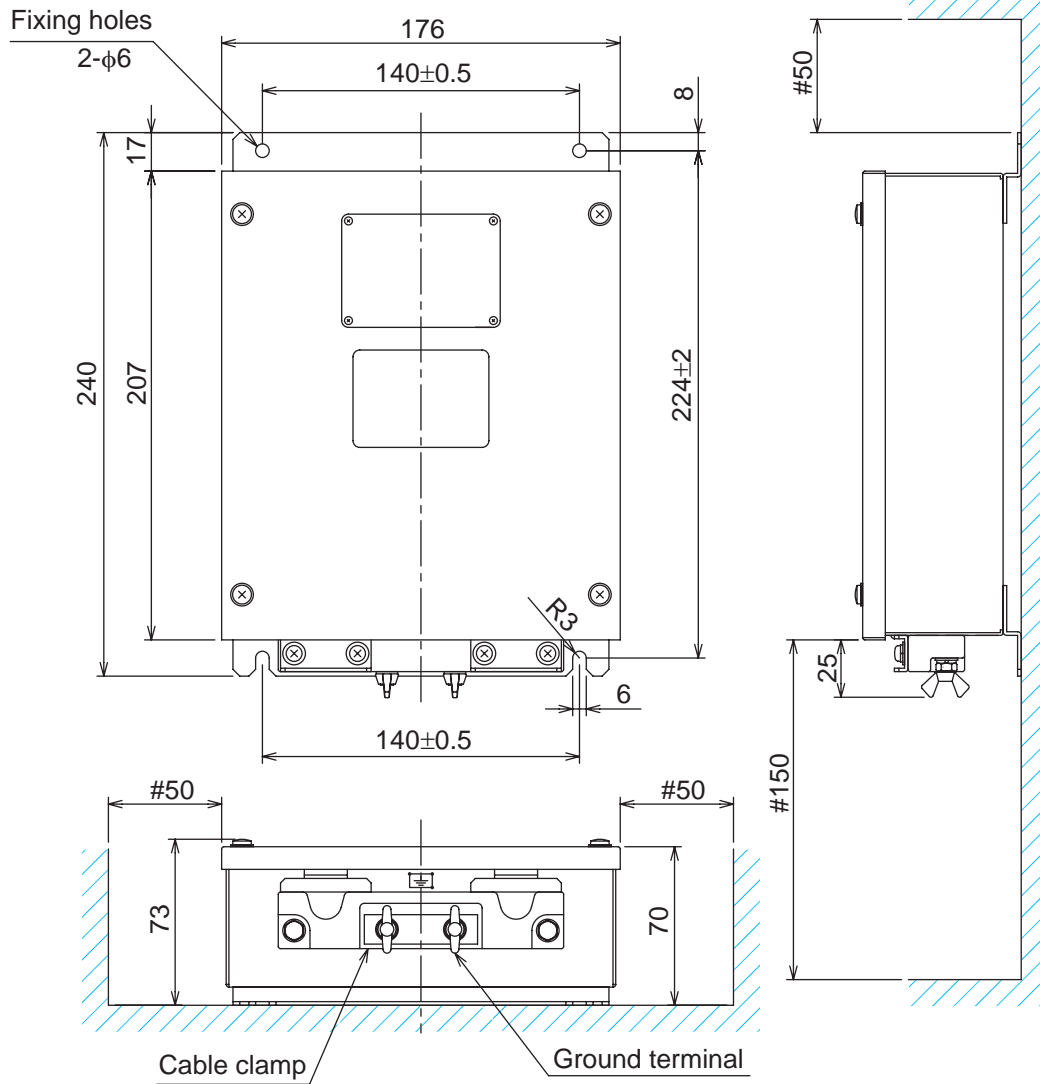

2. WIRING

2.1 Interconnection

Refer to the interconnection diagram at the back of this manual for detailed information.

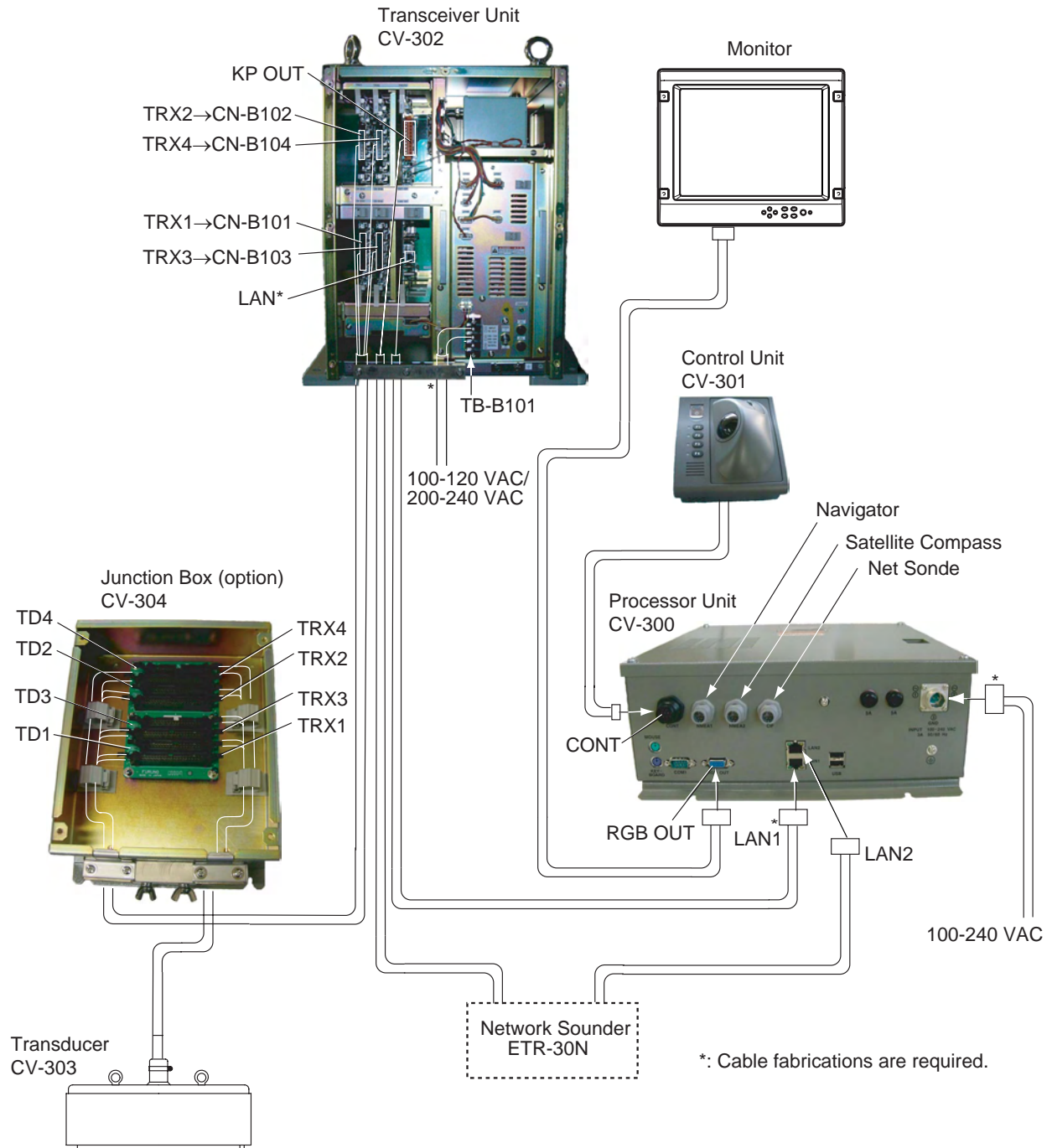

Wiring diagram

Cable running in the junction box

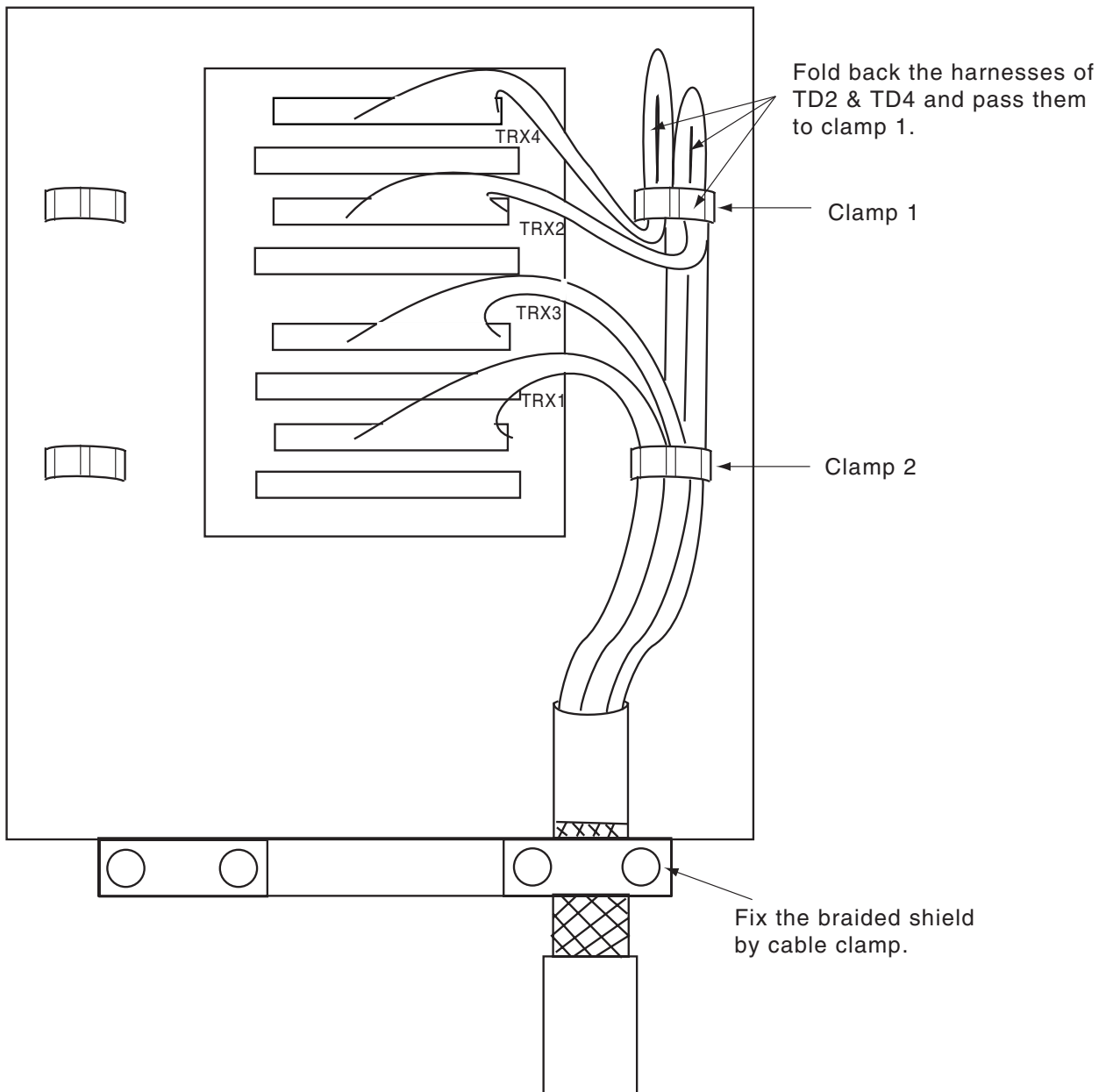

2.2 Cable Fabrication

LAN cable

The LAN cable (FR-FTPC-CY 10, 20, or 30 m) connects between the processor unit and the transceiver unit. Cut armor and outer vinyl sheath as shown below and then connect the modular connector MPS588-C (supplied) to both ends.

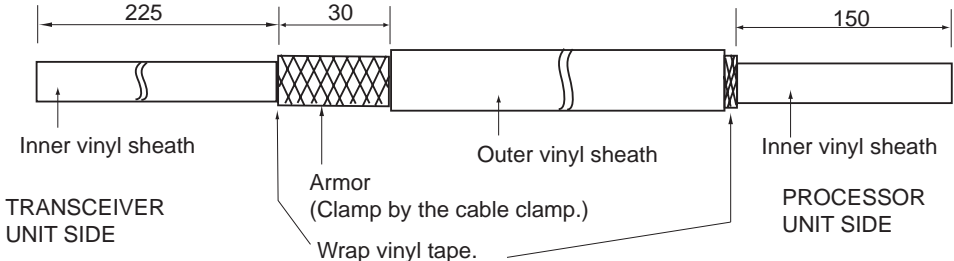

1 Expose inner vinyl sheath.

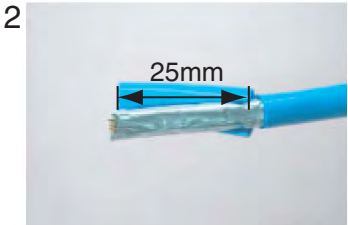

2 Remove the outer sheath by approx 25 mm. Be careful not to damage inner shield and cores.

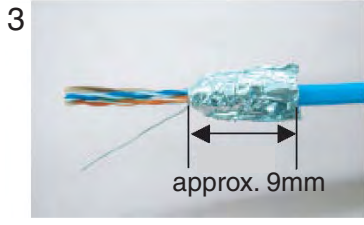

3 Fold back the shield, wrap it onto the outer sheath and cut it, leaving 9 mm.

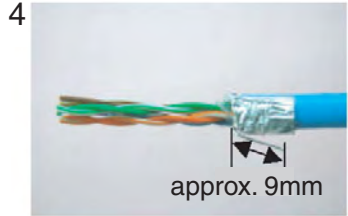

4 Fold back drain wire and cut it, leaving 9 mm.

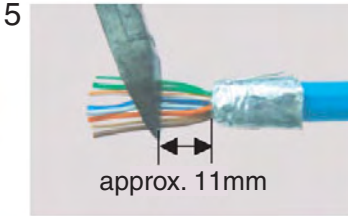

5 Straighten and flatten the core in order and cut then, leaving 11 mm.

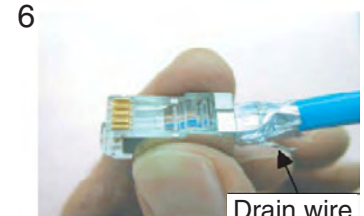

6 Insert the cable into the modular plug so that the folded part of the shield enters into the plug housing. The drain wire should be located on the tab side of the jack.



7 Using special crimping tool MPT5-8 (PANDUIT CORP.), crimp the modular plug. Finally check the plug visually.

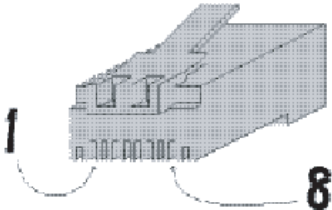
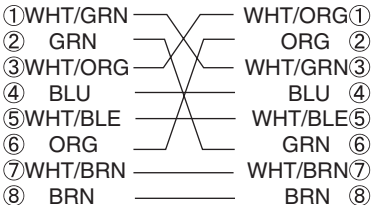

2. WIRING

Power cable for the processor unit

Use power cable DPYC-2.5 (Japan industry standard cable) or equivalent. Connect connector SRCN6A13-3S (supplied) as follows.

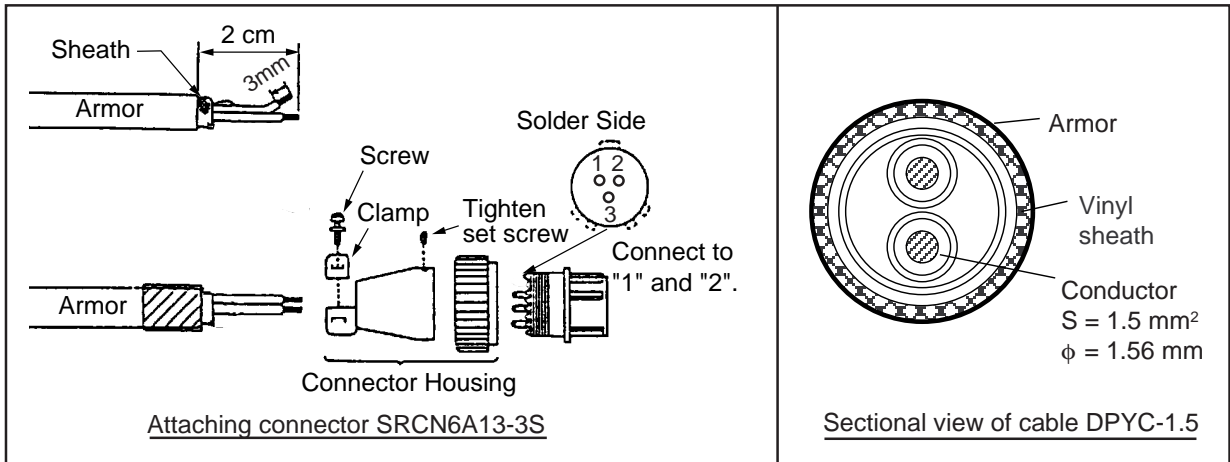

Power cable for the transceiver unit

Use power cable DPYCYS-1.5 (Japan industry standard cable) or equivalent. Connect crimp-on lugs FV5.5-S4 (supplied) as follows.

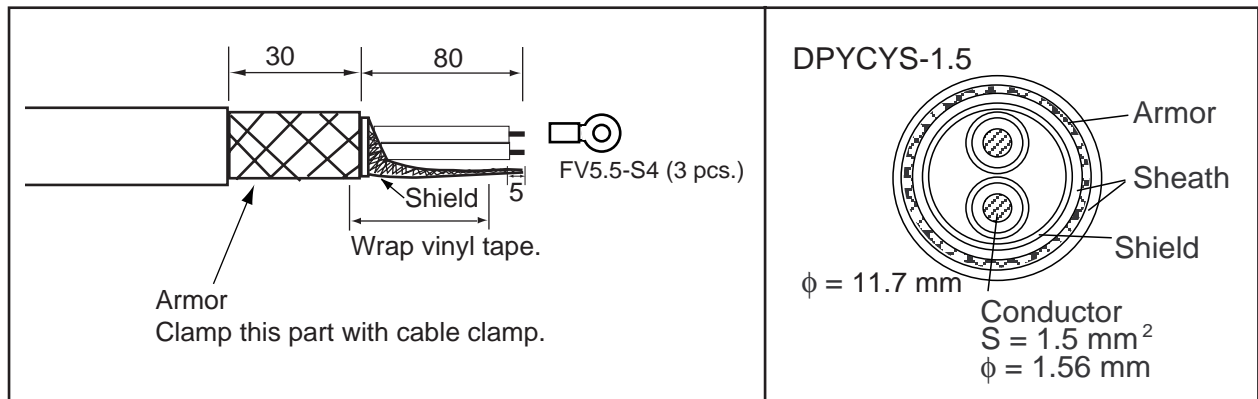

Ground

The processor unit, transceiver unit and junction box should be grounded to prevent electrical shock and mutual interference. Connect an earth plate or earth wire between unit and ship's superstructure to ground.

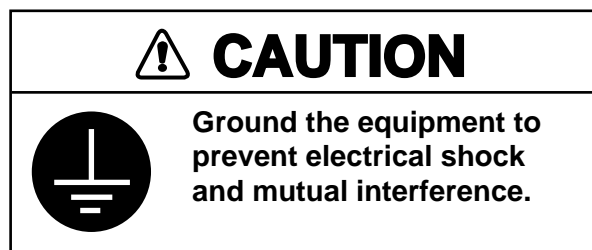

2.3 Synchronizing Transmission with Echo Sounder or Other Sonar

To synchronize transmission of the FCV-30 with an echo sounder or other type of sonar, connect it as shown below. Also, set the **Ping Setting** to **External**, referring to page 3-4 and 3-5 of the FCV-30 Operation manual.

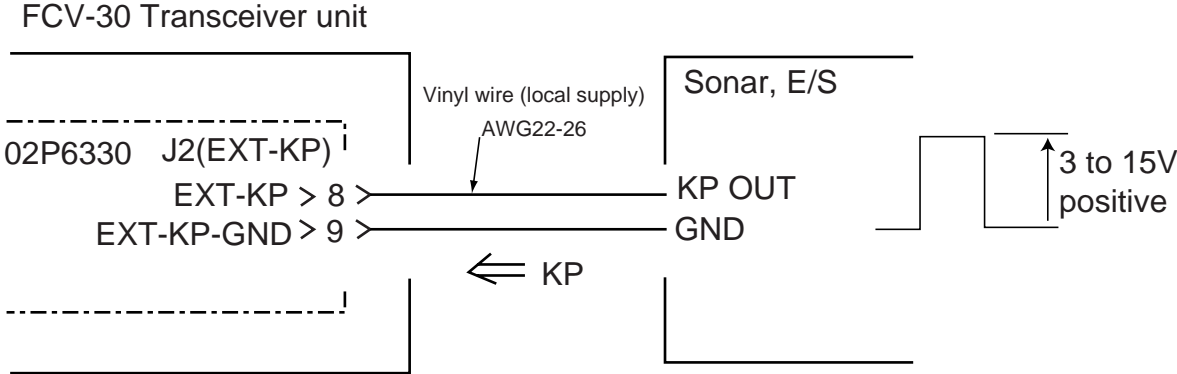

Wiring for WAGO connector

Note: Outputting KP of FCV-30 to other sonar, echo sounder

FCV-30 Transceiver unit

Terminal opener

02P6336 J2(EXT-KP)

12V positive

WAGO connector

Wire

Twist

Procedures

1. Twist the cores
2. Press the terminal opener downward.
3. Insert the wire to hole.
4. Remove the terminal opener.
5. Pull the wire to confirm that it is secure.

⇒ KP (E/S transmits, SONAR)

2.4 Input/Output Sentences

Input sentences (talker not specified)

Sentence	Data	Remarks
GGA	Time, position	NMEA
GLC	GRI, TD (Loran C)	NMEA
GLL	Latitude and longitude	NMEA
GTD	TD (Loran C)	NMEA
MTW	Water temperature	NMEA
RMA	Loran C data (Latitude and longitude, TD, ground speed and course	NMEA
RMB	Recommended minimum navigation information	NMEA
RMC	GNSS data (Latitude and longitude, ground speed and course)	NMEA
VTG	Speed through the ground and course	NMEA
BWC	Bearing and distance to waypoint	NMEA
VHW	Water speed and heading	NMEA
GNS	GNSS fix data	NMEA
ZDA	Time and date	NMEA
hve	Heave information (Satellite compass) P sentence	SC
att	Roll and pitch angle (Satellite compass) P sentence	SC

Output sentences

Talker	Sentence	Data	Remarks
SD	DBS	Depth below sea surface	Ver. 1.5
SD	DBT	Depth below transducer	Ver. 1.5, 2.0, 3.0
SD	DPT	Depth below transducer	Ver. 2.0, 3.0
YC	MTW	Water temperature (With connection of water temperature sensor)	Ver. 1.5, 2.0, 3.0
SD	TLL	Target position	Ver. 1.5, 2.0, 3.0
SD	vrm	VRM depth, P sentence	Ver. 1.5, 2.0, 3.0
SD	btm	Seabed discrimination data	Ver. 1.5, 2.0, 3.0

CIF input signal

Signal	Data	Remarks
58	Temperature	
D3	Sonde no., water temperature, Net depth	

3. SYSTEM SETTINGS AFTER INSTALLATION

After installing all equipments, set up the equipment as shown in this chapter.

The FCV-30 is shipped from the factory ready for connection to an XGA monitor. To connect an SXGA monitor, contact a FURUNO agent or dealer.

System Setting

Do the system settings as follows.

1. Click **System** in the menu bar to open the system menu.

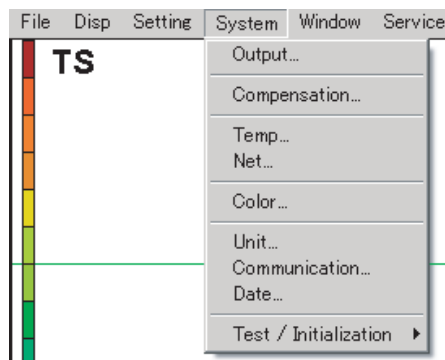

Output

1. Click **Output** in the system menu to show the OUTPUT dialog box.



2. To output the TLL data (when the "Maker Line" in the menu bar is clicked) to external equipment via NMEA port, set **TLL** to **ON**.
3. To output the seabed data to external equipment via NMEA port, set **Bottom discrimination** to **ON**.

Note that this function outputs bottom hardness/roughness in ten levels, however there is currently no receiving device which handles this data.

4. To set NMEA version according to equipment connected, choose the version among 1.5, 2.0 and 3.0.
5. Click the **OK** or **Apply** button.

3. SYSTEM SETTINGS AFTER INSTALLATION

Compensation

1. Click **Compensation** in the System menu to show the Compensation dialog box is displayed.

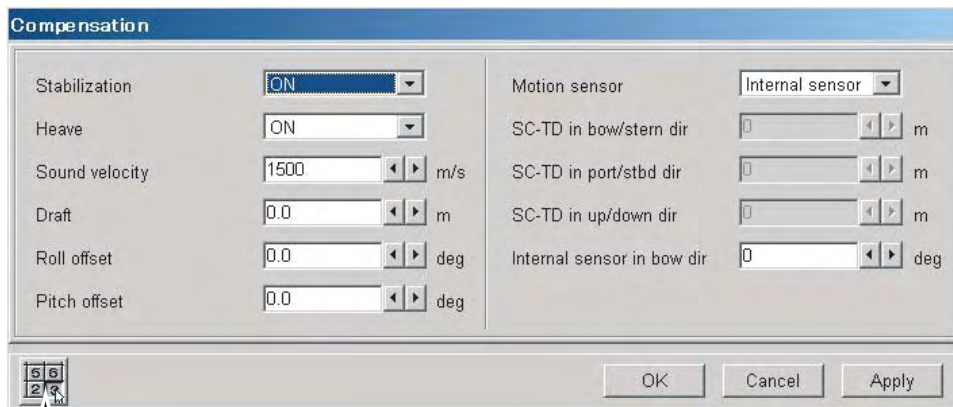

Ten key button

2. Set the following items. To enter numeric values, press the ten-key button at lower left-hand side to open the ten-key panel. Click appropriate numeric keys.

Stabilization: Choose ON to activate the stabilization function.

Heaving: Choose ON to enable the heaving correction function. The satellite compass is required to connect.

Sound velocity: Compensate the sound speed if the depth indicated on the screen is different from the usual depth indication for the area. (Setting range: 1400 to 1600 m/s)

Draft: Set the ship's draft if you want to display the depth from sea surface to seabed rather than from the transducer. (Setting range: -6.0 to +60.0 m)

Roll offset: Compensate the roll angle error of the motion sensor. Set positive values when the starboard is up. (Setting range: -10.0 to +10.0 degrees)

Pitch offset: Compensate the pitch angle error of the motion sensor. Set positive values when the bow is up. (Setting range: -10.0 to +10.0 degrees)

- Note that the satellite compass has its own roll and pitch corrections. Enter compensations here or at the satellite compass; do not compensate at both.

Motion sensor: Choose the internal sensor or SC (Satellite Compass) for stabilization.

SC-TD in longitudinal dir: Set the longitudinal distance from satellite compass antenna (SC) to transducer (TD). If the TD is bow side, set positive values. (Setting range: -100.0 to +100.0 m)

SC-TD in port/stbd dir: Set the transverse distance from SC to TD. If the TD is starboard side, set positive values. (Setting range: -100.0 to +100.0 m)

SC-TD in up/down dir: Set a vertical distance from TD to SC, in positive values. (Setting range: -100.0 to +100.0 m)

Internal sensor in bow dir: If so equipped, correct installation angle error of the internal motion sensor, i.e., the transceiver unit. If the transceiver unit is installed with its front panel facing to the port side exactly, the motion sensor faces the bow at zero degrees. If installed panel facing to the bow, enter 90. (Setting range: 0 to 360 degrees)

- Inscribe this setting value on the NOTE label on the front panel of the transceiver unit.

Temperature

1. Click **Temp** in the system menu to show the “Temp” dialog box.

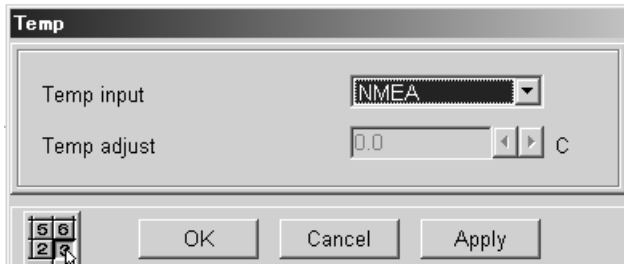

2. Set the following items.
 Temp input: Choose CIF or NMEA as the temperature data source as appropriate.
 Temp adjust: Enter compensation value for CIF input. (Setting range: -20.0 to +20.0 degrees)

Net

1. Click **Net** in the system menu to show the “Net” dialog box.

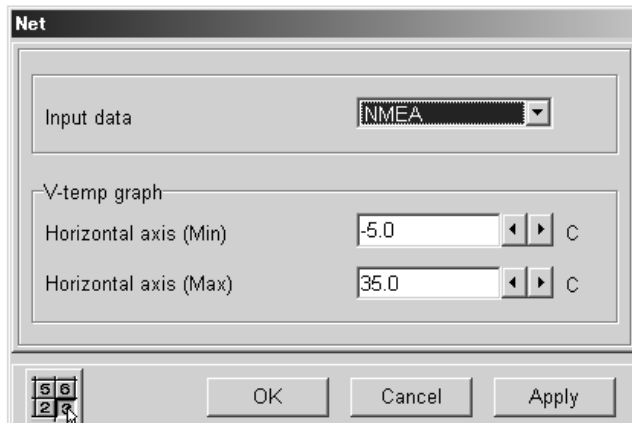

2. Set the following items.
 Input data: Choose CIF or NMEA as the net data source as appropriate.
 CIF: The temperature & depth data from the net recorder.
 NMEA: The temperature & depth data from the trawl sonar.
 Horizontal axis (Min): Set minimum value of the horizontal axis of the vertical temperature graph. (Setting range: -5.0 to +35.0 degrees)
 Horizontal axis (Max): Set maximum value of the horizontal axis of the vertical temperature graph. (Setting range: -5.0 to +35.0 degrees)

3. SYSTEM SETTINGS AFTER INSTALLATION

Communication parameters

1. Click **Communication** in the system menu to show “Communication” dialog box.

Network	
IP address	192 . 168 . 2 . 3
Port	10000

NMEA	
Port	NMEA1
Baud rate	4800 bps
Bit rate	8 bit
Stop bit	1 bit
Parity bit	None

SC	
Port	NMEA2
Baud rate	38400 bps
Bit rate	8 bit
Stop bit	1 bit
Parity bit	None

CIF	
Port	CIF
Baud rate	4800 bps
Bit rate	7 bit
Stop bit	2 bit
Parity bit	Even

2. Set the following items.

IP address: Set the IP address of the network.

Port: Set the port number. Normally no change is required.

Port in the NMEA/SC/CIF field:

COM1: Choose this when an external equipment is connected to COM1 port of the processor unit.

NMEA1: Choose this when an external equipment is connected to NMEA1 port of the processor unit.

NMEA2: Choose this when an external equipment is connected to NMEA2 port of the processor unit.

CIF: Choose this when an external equipment is connected to CIF port of the processor unit.

Baud rate: Set baud rate of the transmission signal among 4800, 9600, 19200 and 38400 bps for NMEA and 600, 1200, 2400 and 4800 bps for CIF.

Bit rate: Set the character size of the transmission data between 7 bit and 8 bit.

Stop bit: Set the stop bit size of the transmission data among 1 bit, 1.5 bit and 2 bit.

Parity bit: Set the parity of the transmission data among none, odd and even.

Note: To output data from SC-50/110 in NMEA format, set the SC-50/110 as follows.

-Output format: IEC ed1

-Sentence: ATT, HVE (For others, set all OFF.)

-Baud rate: 38400 bps

-Cycle: 25 ms

(Talker : any)

Setting the Date

1. Click the **Date** in the system menu. The Date dialog box is displayed.

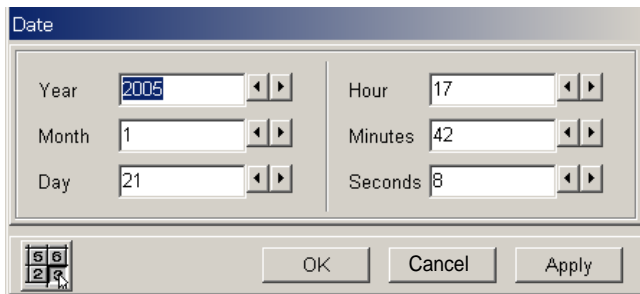

2. Using ◀ or ▶ or ten-key panel, enter current date and time.
3. Click the **OK** or **Apply** button. From this moment, the time counts up.

Note that the date and time are not displayed on the screen, however data files which are downloaded are named by date and time. The time is backed up by the internal battery cell.

Transducer parameters

The data sheets about the transducer parameters are attached to the transducer. Detach them and attach one on the display unit and one to last page of the operator's manual. The compensation data on the sheet should be entered here. However, this compensation can be done by only serviceman.

1. Using the mouse wheel, double-click the space just below the right edge of the menu bar. Left-click **2005** followed by **ENTER** to open the Service menu.

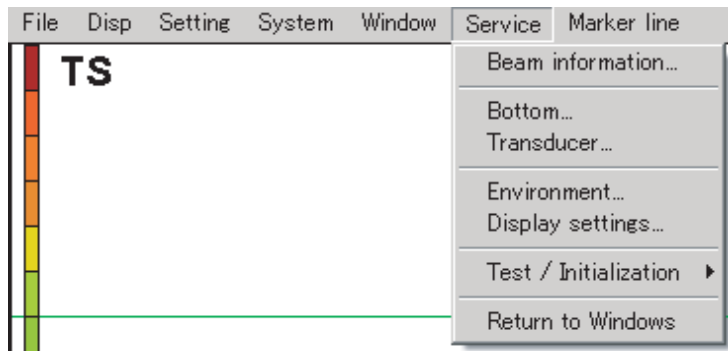

2. Choose **Service – Transducer** in the menu bar to show the Transducer dialog box.

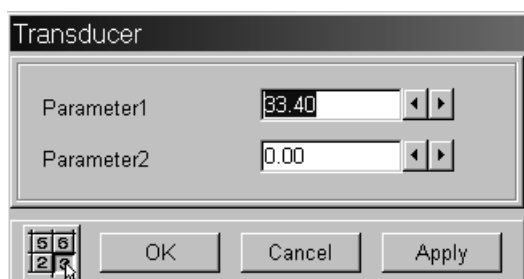

3. Enter the parameters in the Parameter1 and Parameter2 boxes, referring to the parameter sheet attached to the transducer cable. If the parameter 2 in the parameter sheet is blank, leave the setting 0.00.

3. SYSTEM SETTINGS AFTER INSTALLATION

4. Click the **OK** button to close the dialog box.
5. Using the mouse wheel, double-click the space just below the right edge of the menu bar.
The Service menu disappears. Also, the Service menu disappears by turning off and on the FCV-30.

Note: Do not change the setting in the **Beam Information**, **Bottom** or **Environment** in the **Service** menu at installation.

Network Sounder Setting

When connecting the network sounder ETR-30N, set the transducer (frequency) and network.

Transducer (frequency) setting

1. Click **ETR** in the **File** menu to show the ETR window.
2. Hold down [F1] and [F4] key and click the **System** in the ETR window.

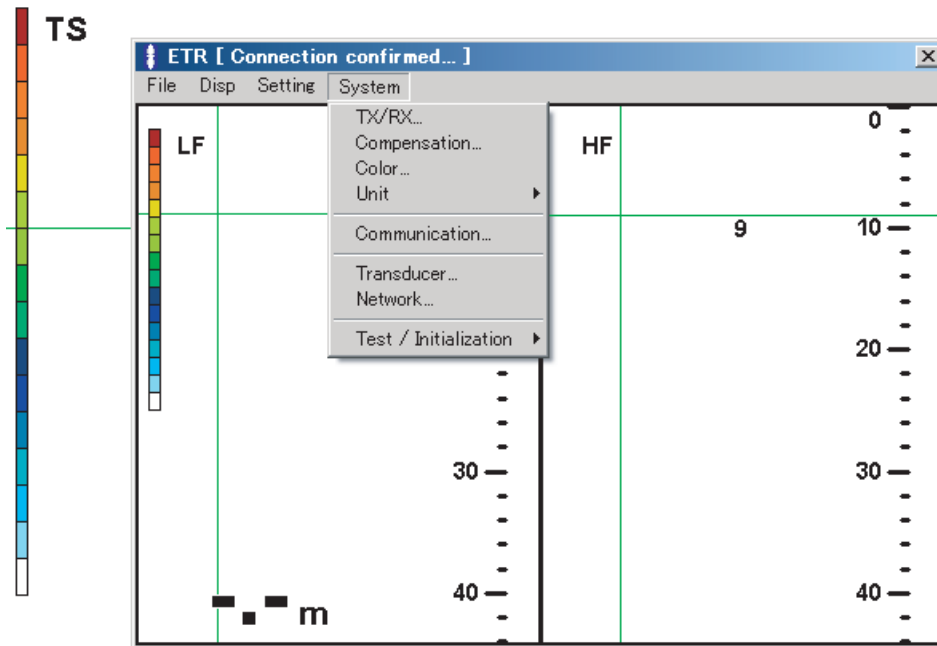

3. Click **Transducer** to show the ETR Transducer window.

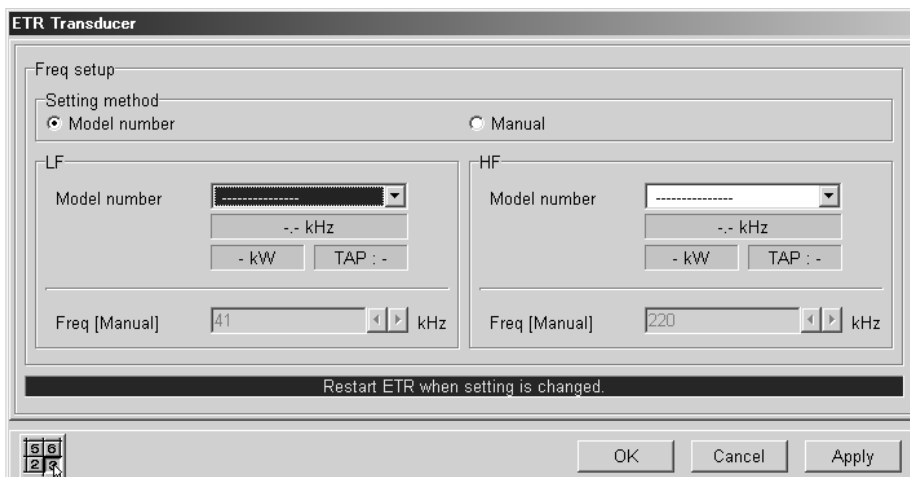

- If the transducer to be used is programmed in the FCV-30, choose **Model number** in the Setting method box, and choose the model in LF or HF box.

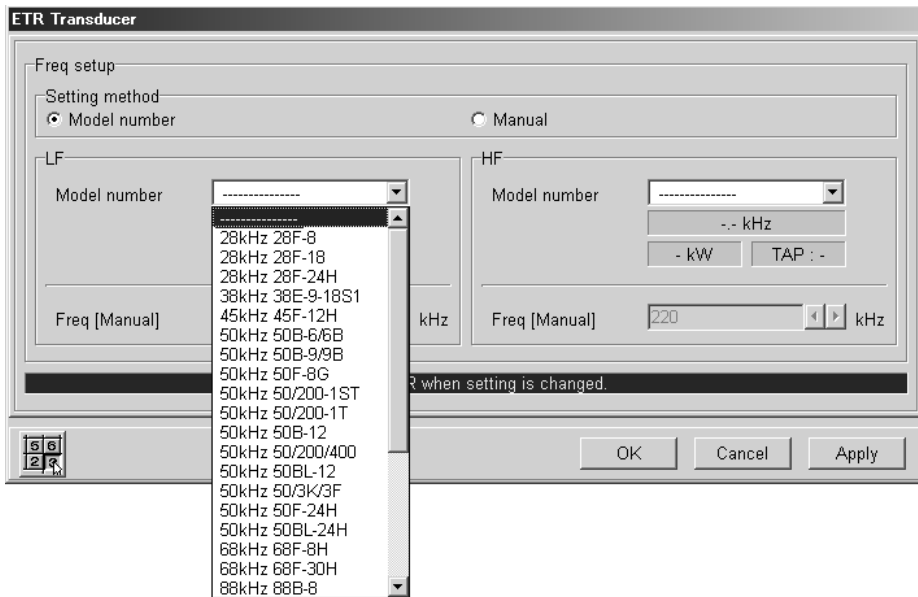

Note: Change the tap inside the ETR-30N according to the character which appears next to “TAP”: A to D displayed beneath the frequency. For details, see the Operator’s Manual for the ETR-30N.

- If the transducer is not programmed in the FCV-30, choose **Manual** in the Setting method box, and enter the frequency manually by the keyboard or use ◀ or ▶ button (Setting range: 25 to 220 kHz).
- Click the **Apply** button and then the **OK** button.

Network Setting

- Hold down [F1] and [F4] key and click the **System** in the ETR window.
- Click Network to show the ETR Network window.



- Choose the Host name from the drop-down menu according to ETR-30N setting. Choose **SOUNDER** when Host name of ETR-30N is 0, and choose **SOUNDER 1** when Host name of ETR-30N is 1, etc. For details, see the Operator’s Manual for ETR-30N.
- Click the **Apply** button and then the **OK** button.

Note: After changing setting, reboot ETR-30N.

表 1 TABLE 1

寸法区分 (mm) DIMENSIONS	公差 (mm) TOLERANCE
$L \leq 50$	± 1.5
$50 < L \leq 100$	± 2.5
$100 < L \leq 500$	± 3

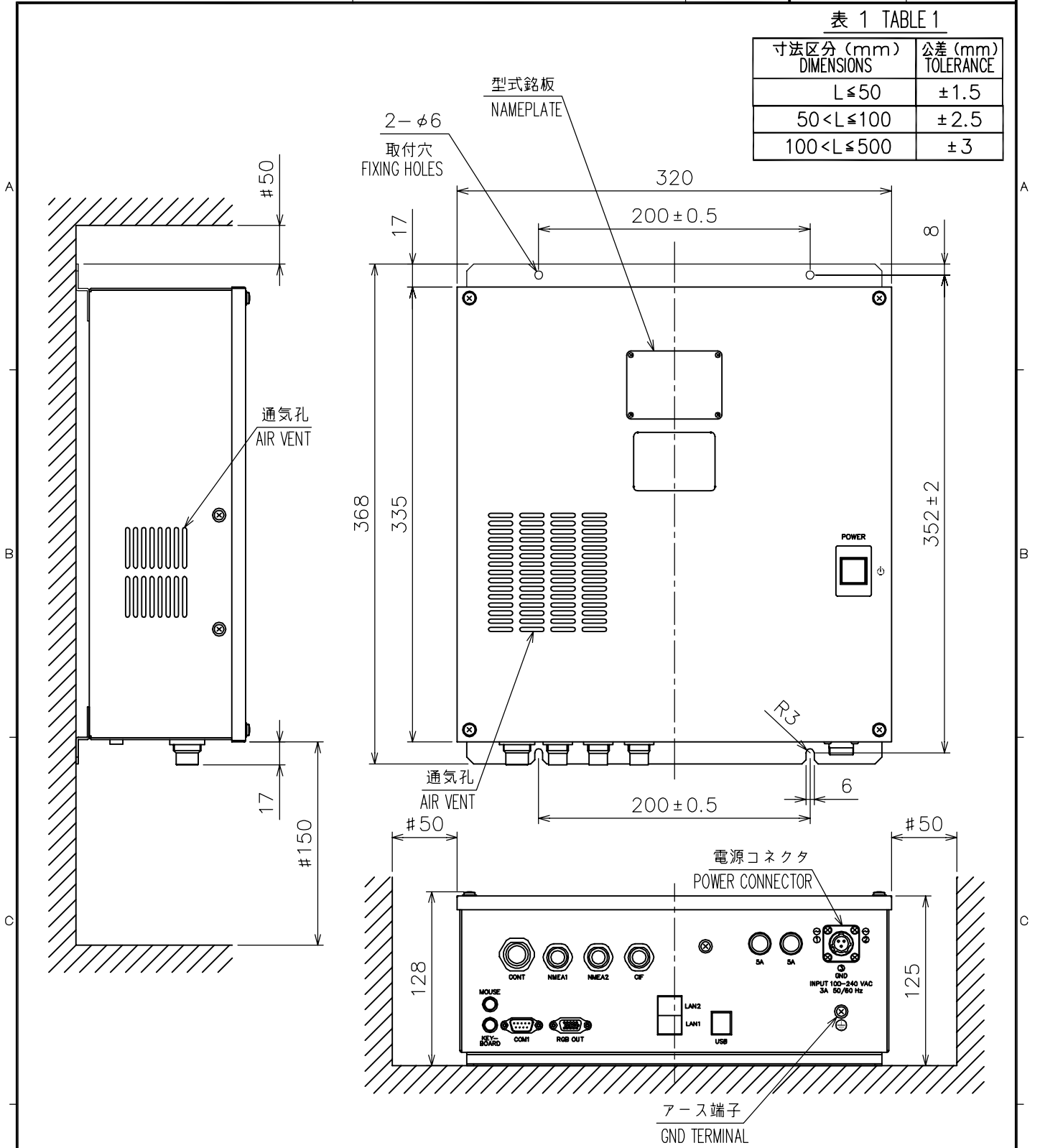

注 記

- 1) #印寸法は最小サービス空間寸法とする。
- 2) 指定外の寸法公差は表 1 による。
- 3) 取付は M5 ボルトを使用のこと。
- 4) 通気孔 (2カ所) の前は塞がないこと。

NOTE

1. # MINIMUM SERVICE CLEARANCE.
2. TABLE 1 INDICATES TOLERANCE OF DIMENSIONS WHICH IS NOT SPECIFIED.
3. USE M5 BOLTS FOR FIXING THE UNIT.
4. DO NOT OBSTRUCT VENTS (2).

DRAWN Jan. 19, '05 E. MIYOSHI		TITLE CV-300
CHECKED TAKAHASHI. T		名称 演算部 (壁掛け装備)
APPROVED Y. Hatai	FCV-30	外寸図
SCALE 1/4 MASS 7.5 ±10% kg		NAME PROCESSOR UNIT (BULKHEAD MOUNT TYPE)
DWG.No. C2373-G02-A	02-153-100G-0	OUTLINE DRAWING

表 1 TABLE 1

寸法区分 (mm) DIMENSIONS	公差 (mm) TOLERANCE
L ≤ 50	± 1.5
50 < L ≤ 100	± 2.5
100 < L ≤ 500	± 3

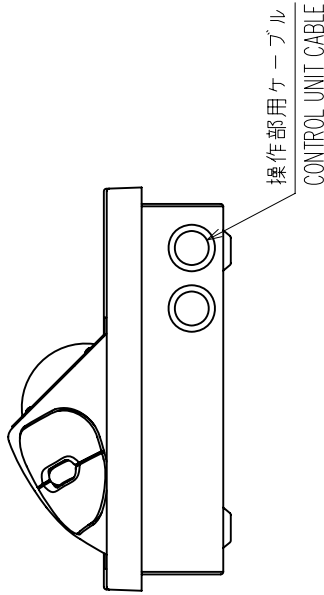
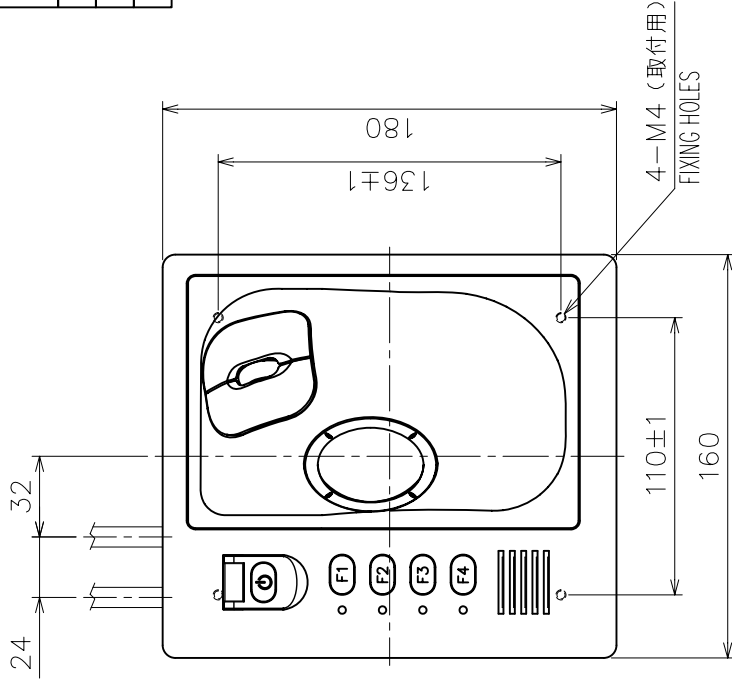

矢視A
VIEW A

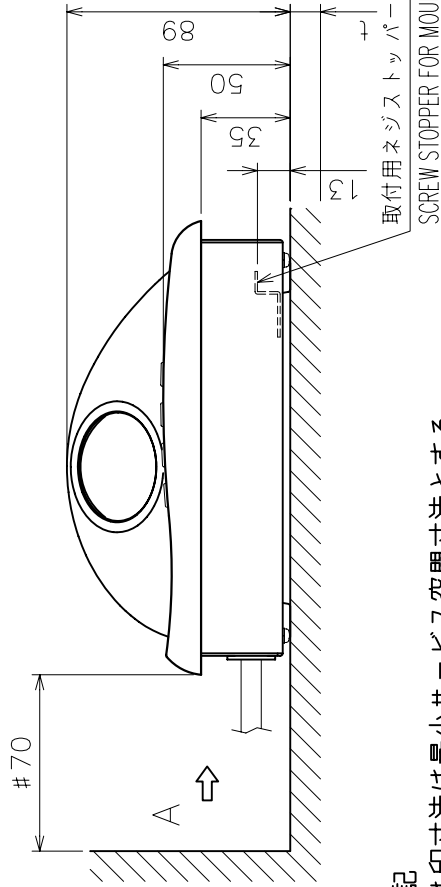

注 記

- 1) #印寸法は最小サービス空間寸法とする。
- 2) 指定外の寸法公差は表1による。
- 3) 取付用ネジは、セムスネジB M4X12を使用のこと。
取付面板厚は最小2最大5とする。
それ以外はネジ長さM4X(t+7.8±2)のセムスBを使用のこと。

NOTE

1. # MINIMUM SERVICE CLEARANCE.
2. TABLE 1 INDICATES TOLERANCE OF DIMENSIONS WHICH IS NOT SPECIFIED.
3. FOR FIXING, USE M4X12 SCREWS.
MOUNTING PLATE THICKNESS SHALL BE BETWEEN 2 AND 5 MM.
FOR GREATER THICKNESS, SCREW LENGTH SHALL BE M4 x (t + 7.8 ±2).

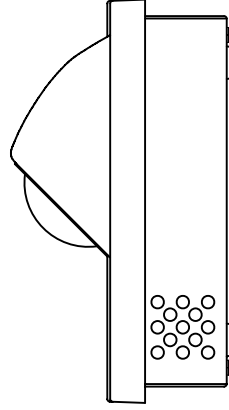

DRAWN	Jul. 17, 06 Maki	TITLE	CV-301
CHECKED	TAKAHASHI, I	各 部 名	操作部 (卓上装備)
APPROVED	Y. Hatai	外 寸 図	外 寸 図
SCALE	1/3 MASS 1.8 kg ±10% 質量保証ケーブル質量を含む。 ±10% MASS W/ 5m CABLE	NAME	CONTROL UNIT (TABLETOP MOUNT)
DWG.No.	C2373-003-C		OUTLINE DRAWING
			02-153-200G-1

表 1 TABLE 1

寸法区分 (mm) DIMENSIONS	公差 (mm) TOLERANCE
L ≤ 50	± 1.5
50 < L ≤ 100	± 2.5
100 < L ≤ 500	± 3

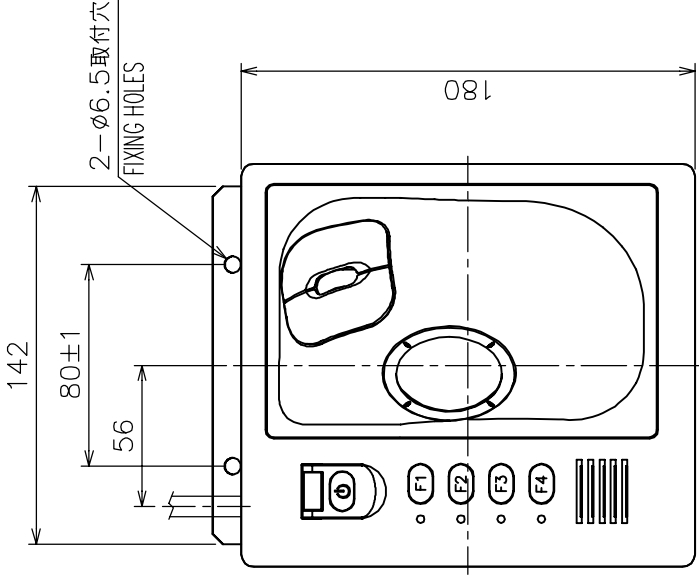

矢視 A VIEW A

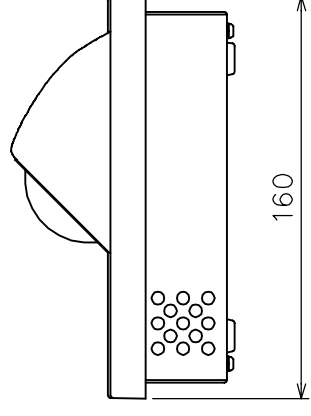

矢視 B VIEW B

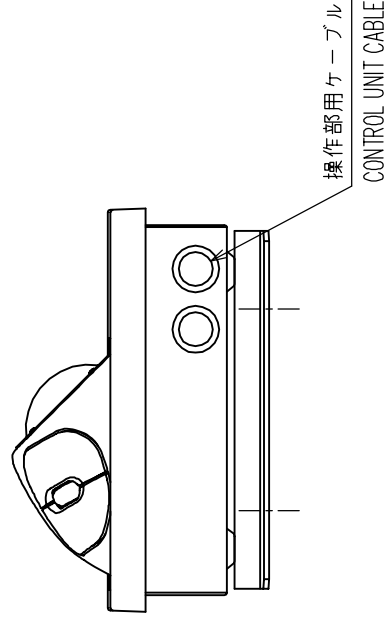

矢視 D VIEW D

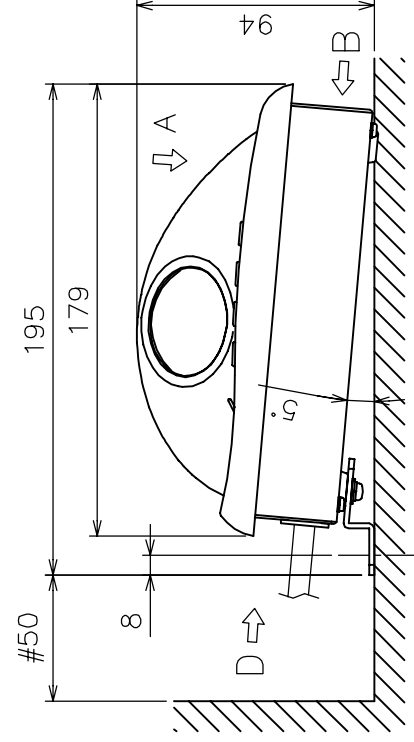

- 注 記
- 1) # 印寸法は最小サービス空間寸法とする。
 - 2) 指定外の寸法公差は表 1 による。
 - 3) 取付用ネジはトラスタップピネジ呼び径6、またはM6 ボルトを使用のこと。
- NOTE
1. # MINIMUM SERVICE CLEARANCE.
 2. TABLE 1 INDICATES TOLERANCE OF DIMENSIONS WHICH IS NOT SPECIFIED.
 3. FOR FIXING, USE M6 SELF-TAPPING SCREWS OR M6 BOLTS.

DRAWN	Jan. 27, '05 E. MIYOSHI	TITLE	CV-301
CHECKED	TAKAHASHI, T	名称	操作部 (卓上装備金具付)
APPROVED	Y. Hatai	外寸図	
SCALE	1/3 質量 1.8 kg	NAME	CONTROL UNIT (TABLETOP W/MOUNTING FIXTURE)
DWG.No.	C2373-G06-A		OUTLINE DRAWING

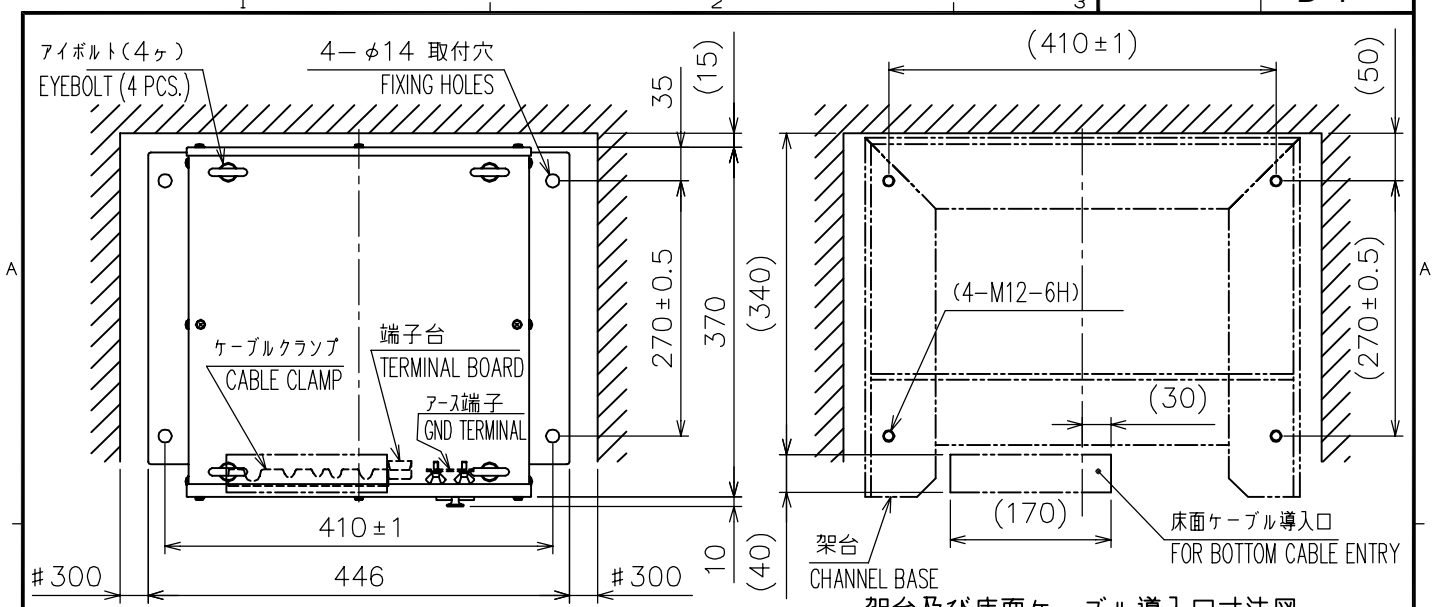

架台及び床面ケーブル導入口寸法図
CHANNEL BASE & DECK-SIDE CABLE ENTRY



表 1 TABLE 1

寸法区分 (mm) DIMENSIONS	公差 (mm) TOLERANCE
$L \leq 50$	± 1.5
$50 < L \leq 100$	± 2.5
$100 < L \leq 500$	± 3
$500 < L \leq 1000$	± 4

注 記

- 1) #印寸法は最小サービス空間寸法とする。
- 2) 指定外の寸法公差は表 1 による。
- 3) 取付用ネジは M12 ボルト (材質: SUS304) を使用のこと。
- 4) 架台及び床面ケーブル導入口の寸法は参考寸法とする。
直接床置きの場合のみ床面ケーブル導入口を設け、
架台取付けの場合架台は造船所手配とする。(架台材質: SS400)

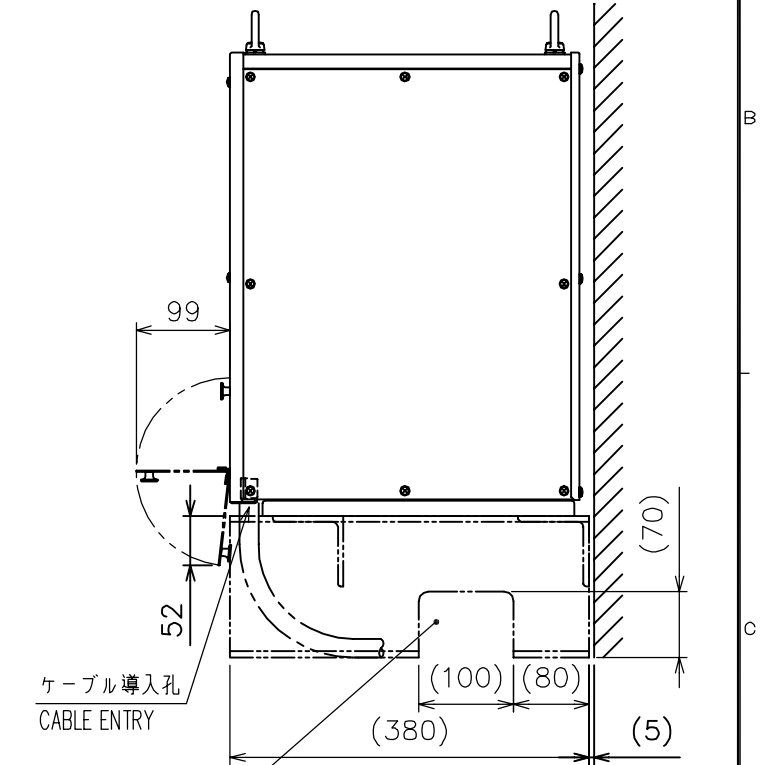
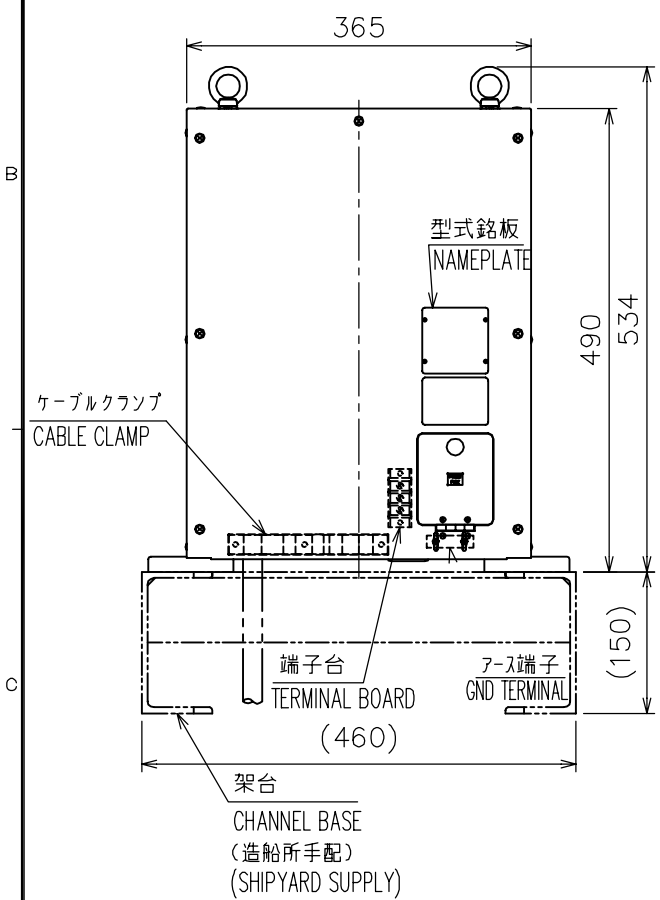
NOTE

1. #: MINIMUM SERVICE CLEARANCE.
2. TABLE 1 INDICATES TOLERANCE OF DIMENSIONS WHICH IS NOT SPECIFIED.
3. USE M12 BOLTS (SUS 304) FOR FIXING.
4. DIMENSIONS OF MOUNTING BASE AND DECK SIDE CABLE ENTRANCE SHOWN FOR REFERENCE.
USE DECK SIDE CABLE ENTRANCE WHEN MOUNTING DIRECTLY ON DECK.
MOUNTING BASE SHOULD BE SUPPLIED LOCALLY. (MATERIAL: SS400)

DRAWN Jan. 27, '05 E. MIYOSHI	TITLE CV-302
CHECKED TAKAHASHI. T	名称 送受信装置 (床置きタイプ)
APPROVED Y. Hatai	外寸図
SCALE 1/8 MASS 34 ±10% kg	NAME TRANSCEIVER UNIT (DECK MOUNT TYPE)
DWG.No. C2373-G04-A	02-153-300G-1 OUTLINE DRAWING

表 1 TABLE 1

寸法区分 (mm) DIMENSIONS	公差 (mm) TOLERANCE
$L \leq 50$	± 1.5
$50 < L \leq 100$	± 2.5
$100 < L \leq 500$	± 3

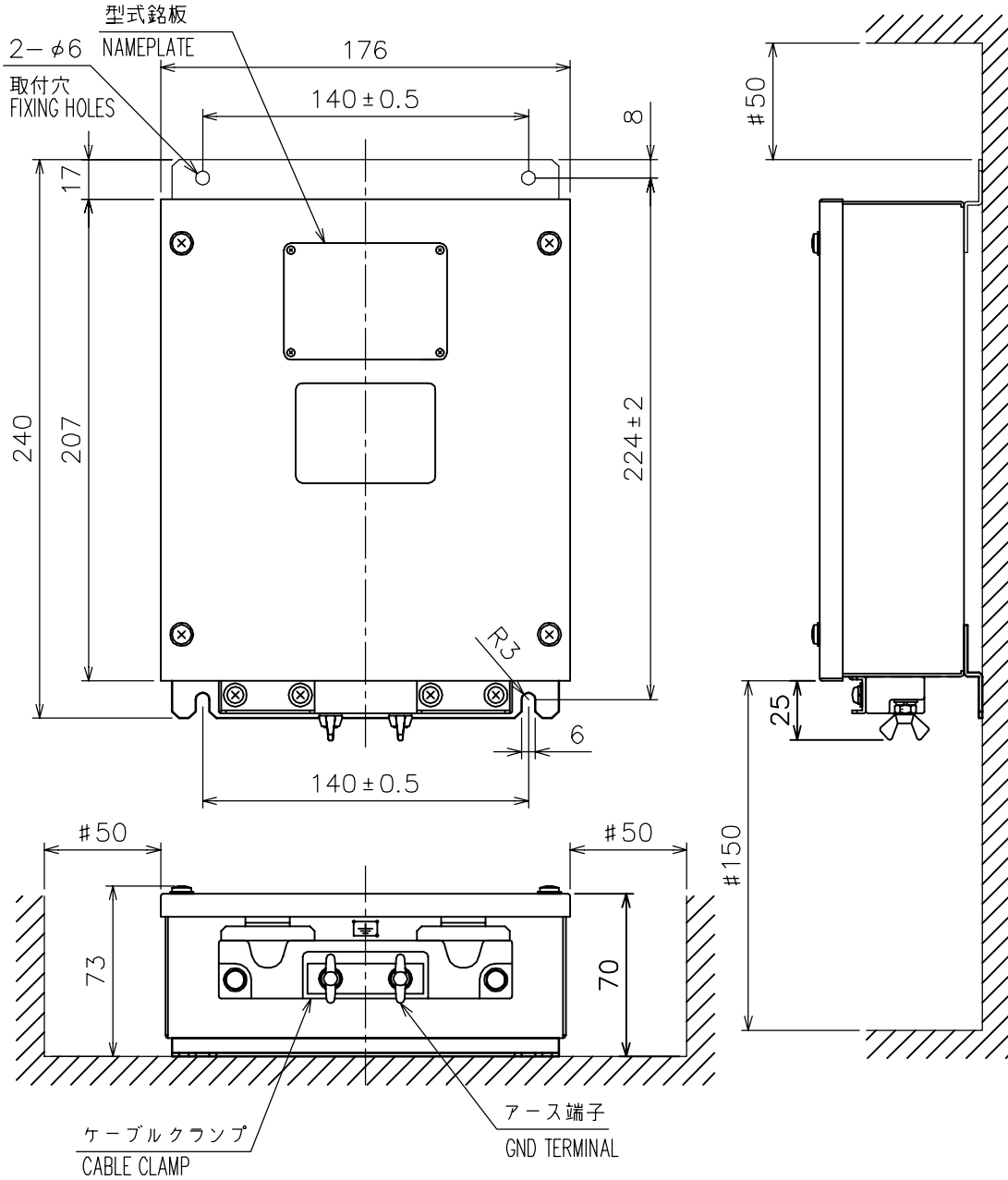

注 記

- 1) #印寸法は最小サービス空間寸法とする。
- 2) 指定外の寸法公差は表 1 による。
- 3) 取付用ボルトは M5 を使用のこと。

NOTE

1. # MINIMUM SERVICE CLEARANCE.
2. TABLE 1 INDICATES TOLERANCE OF DIMENSIONS WHICH IS NOT SPECIFIED.
3. USE M5 BOLTS FOR FIXING THE UNIT.

DRAWN Jan. 19, '05 E. MIYOSHI		TITLE CV-304
CHECKED TAKAHASHI. T		名称 接続箱 (壁掛けタイプ)
APPROVED Y. Hatai	FCV-30	外寸図
SCALE 1/3 MASS 1.6 ±10% kg		NAME JUNCTION BOX (BULKHEAD MOUNT TYPE)
DWG.No. C2373-G05-A	02-153-500G-0	OUTLINE DRAWING

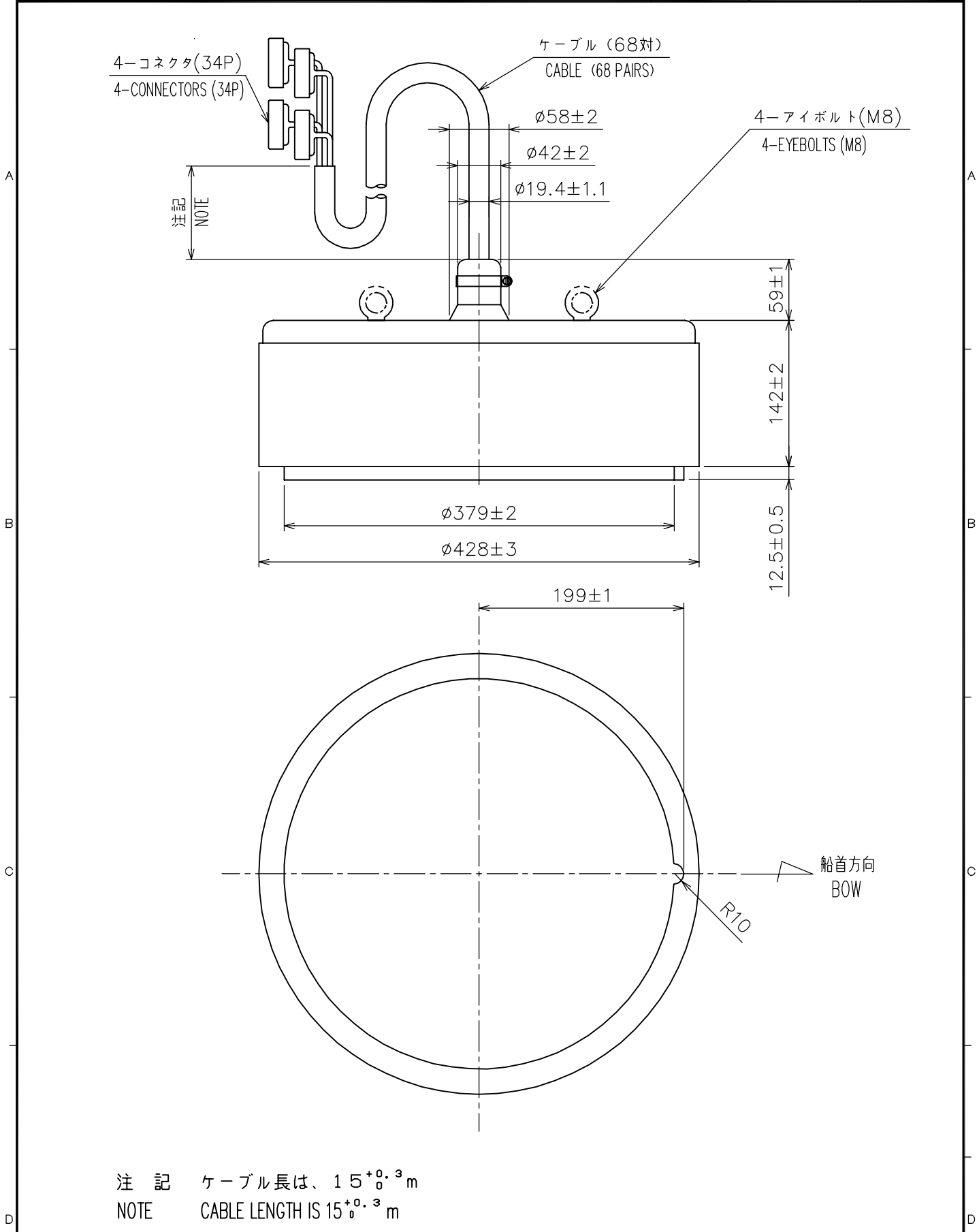

DRAWN	Mar. 22, '05 E. MIYOSHI		TITLE	CV-303
CHECKED	TAKAHASHI. T		名称	送受波器
APPROVED	Y. Hatai	FCV-30		外寸図
SCALE	1/5	MASS 42 ± 10% kg	質量は、ケーブルを含む。 MASS INCLUDES CABLE.	NAME
DWG.No.	C2373-G01-A	02-153-400G-2		TRANSDUCER
				OUTLINE DRAWING

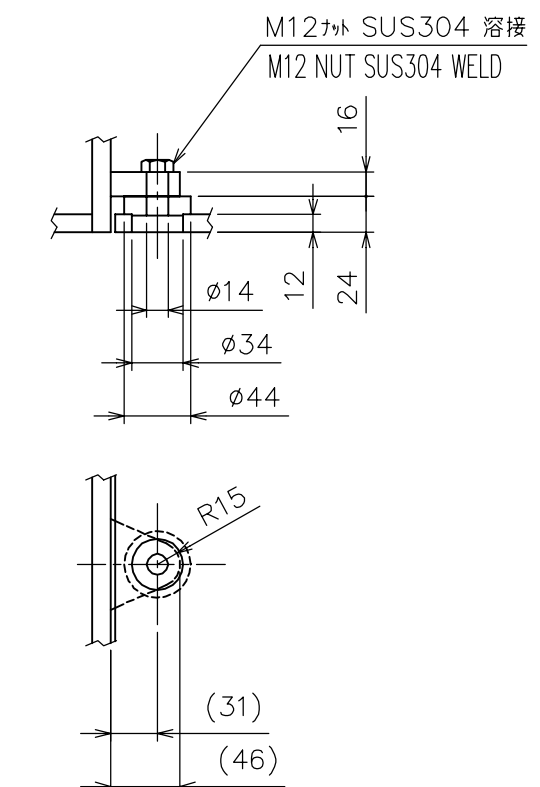
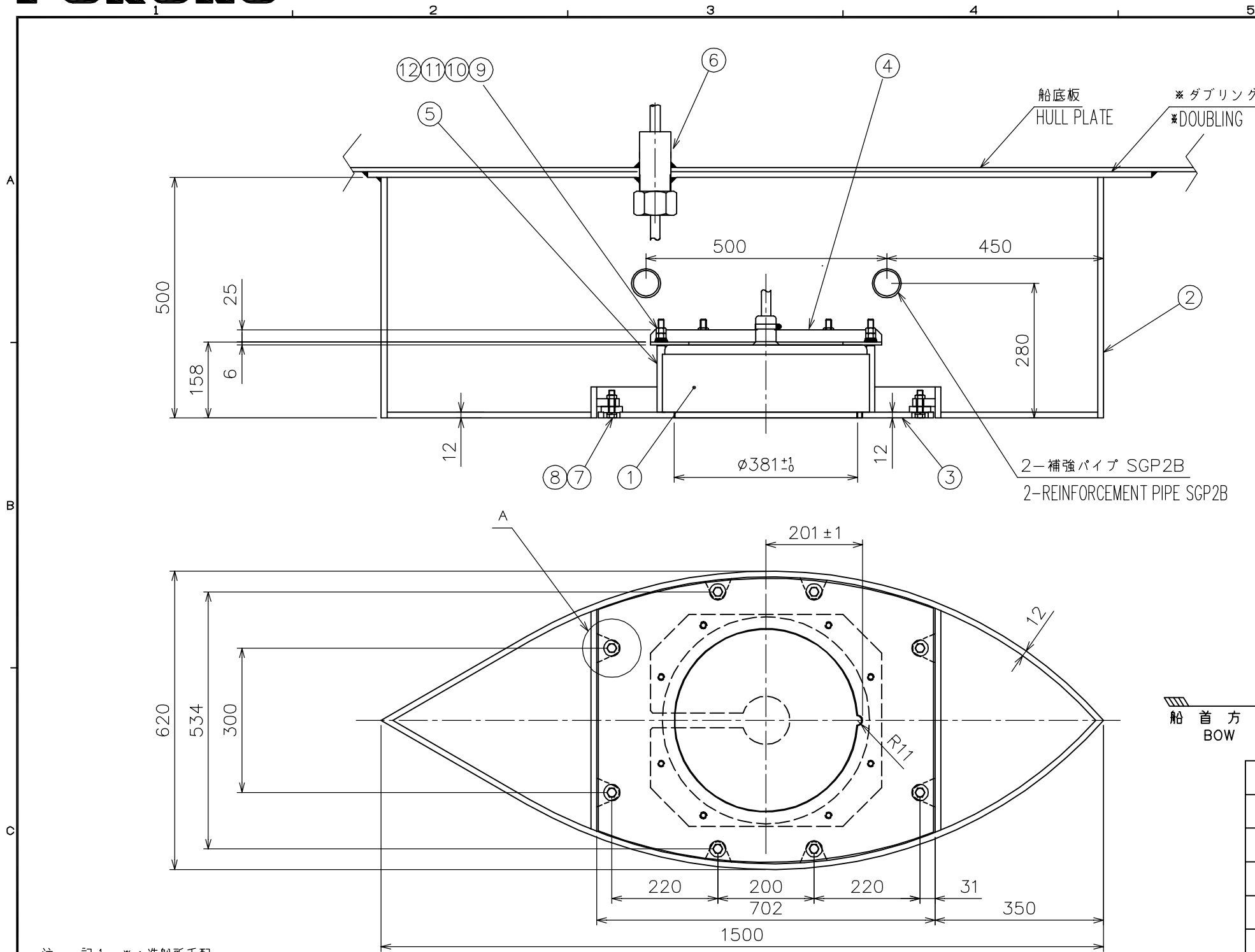

A部詳細 尺度 1/5
DETAIL A (SCALE:1/5)

装備法分類番号 INSTALLATION METHOD	D-7 T-
周波数 FREQUENCY	/ kHz

表1 (Table1)

寸法区分 (mm) Dimension	公差 (mm) Tolerance
L ≤ 50	±1.5
50 < L ≤ 100	±2.5
100 < L ≤ 500	±3
500 < L ≤ 1000	±4
1000 < L ≤ 2000	±5
2000 < L ≤ 4000	±7
4000 < L ≤ 8000	±10
8000 < L	±15

要目表
PRINCIPAL ITEMS

位置 POSITION	項目 ITEM	単位 UNIT
船首から FROM BOW		m
キールから FROM KEEL		mm
突出量H PROJECTION		mm
取付状態 FIXING CONDITION	走行時水平 HORIZONTAL AT RUNNING	
保護タンク PROTECTION TANK		

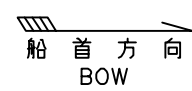

品番 ITEM	品名 NAME	材質 MATERIAL	数量 QTY	図番 DWG.NO.	摘要 REMARKS
12	平座金 FLAT WASHER	POM	8	T-201-11	
11	平座金 FLAT WASHER	SUS316L	8	M12	
10	バネ座金 SPRING WASHER	SUS316L	8	M12	
9	六角ナット HEX.NUT	SUS316L	16	M12	
8	バネ座金 SPRING WASHER	SUS316L	8	M12	
7	六角ボルト HEX.BOLT	SUS316L	8	M12X50	
6	電線貫通金物 THRU-HULL PIPE		1	TFB-1600	
5	スペーサ SPACER	SGP	8	02-153-4303	
4	押え板 FIXING PLATE	SS400	1	02-153-4302	
3	送受波器取付フランジ FIXING FLANGE	SS400	1	02-153-4301	
2	タンク本体 CASING	SS400	1	02-080-2001	
1	送受波器 TRANSDUCER		1	CV-303	表記質量に含まず NOT INCLUDED IN MASS.

- 注 記 1. *:造船所手配
- 切断・溶接の際は、歪み防止のため送受波器を取り外した状態の”送受波器取付フランジ”を必ず取り付けておいてください。
 - 電線貫通金物を溶接する際は、パッキンを取外して行ってください。
 - 送受波器ケース取付の際には船首、船尾の確認をしてください。
 - 船尾側上端に空気抜き用穴(φ10~φ20程度)をあけてください。
 - 電線貫通金物はフレーム等の邪魔にならない所で送受波器に当たらずキャップナットが容易に締め付けられる位置に取り付けてください。
 - 網除け、保護タンクは必要に応じて造船所にて製作してください。
 - 装備後はサビ止め塗装をはがした後正規の塗装をおこなってください。
 - 塗装の際、送受波器面を塗装しない様に注意してください。
 - 送受波器取付け後、A部の隙間をシリコン等で埋めてください。
 - 指定外の寸法公差は、表1のとおりです。
 - ボルト類には焼き付き防止グリス(モリシ-ラ1910等)を塗布してください。
 - 表記質量に送受波器の質量は、含まれていません。

- NOTE 1. *:SHIPYARD SUPPLY
- TO AVOID DISTORTION BY HEAT, PUT "FIXING FLANGE" (WITHOUT TRANSDUCER) ONTO CASING WHILE CUTTING AND/OR WELDING.
 - REMOVE GASKET FROM THRU-HULL PIPE BEFORE WELDING.
 - CASING SHOULD FACE BOW DIRECTION.
 - MAKE A HOLE OF 10 TO 20MM IN DIA ON STERN SIDE TO ALLOW AIR TO ESCAPE FROM TANK.
 - ALLOW ENOUGH CLEARANCE AROUND THRU-HULL PIPE FOR EASY TIGHTENING AND SERVICING.
 - IF NECESSARY, PROVIDE NET PROTECTOR AND PROTECTION TANK (BY SHIPYARD.)
 - AFTER INSTALLATION, REMOVE ANTICORROSIVE PAINT FROM CASING AND THEN PAINT ACCORDING TO SHIPYARD INSTRUCTIONS.
 - DO NOT PAINT TRANSDUCER FACE.
 - "A": FILL GAP AROUND BOLT WITH SILICON SEALANT.
 - TABLE 1 INDICATES TOLERANCE OF DIMENSIONS WHICH IS NOT SPECIFIED.
 - APPLY BURNPREVENTION GREASE TO BOLTS.
 - MASS SHOWN IS TANK WITHOUT TRANSDUCER.

DRAWN Apr. 5, '05	E. MIYOSHI	TITLE T-625
CHECKED	TAKAHASHI. T	名称 送受波器
APPROVED	Y. Hatai	FCV-30
SCALE	1/10	NAME TRANSDUCER
DWG.No.	C2373-T01-C	02-153-4300-3
		TRANSDUCER INSTALLATION

4

3

2

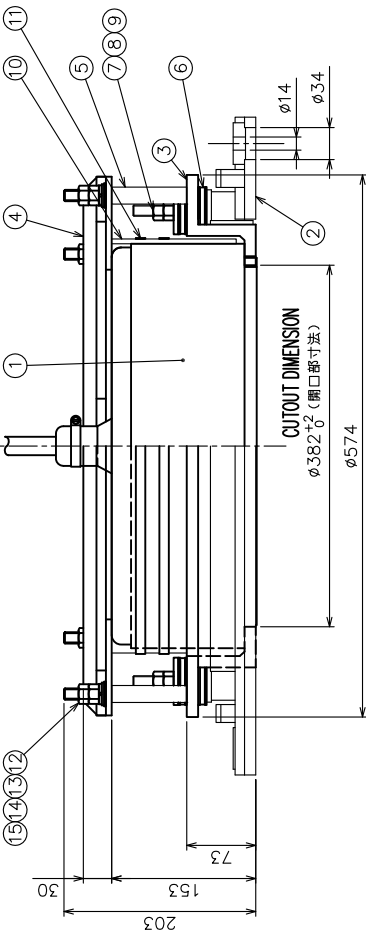

船首方向
FORWARD
DIRECTION

表1 (Table1)

寸法区分 Dimension	公差 (mm) Tolerance
L ≤ 50	±1.5
50 < L ≤ 100	±2.5
100 < L ≤ 500	±3
500 < L ≤ 1000	±4

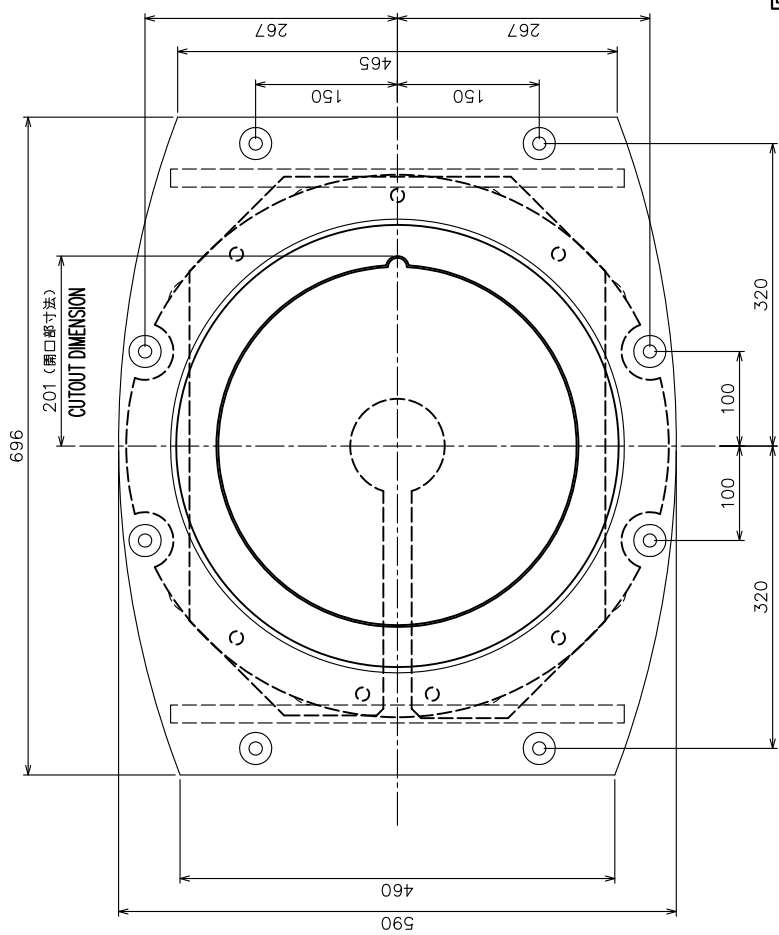

注記

1) 指定なき寸法公差は表1による。

NOTE

1. TABLE 1 INDICATES TOLERANCE OF DIMENSIONS WHICH IS NOT SPECIFIED.

品番 ITEM	品名 NAME	材質 MATERIAL	数量 QTY	図番 DWG.NO.	備考 REMARKS
15	六角ナット HEX.NUT	SUS316L	14	M12	
14	バネ圧金 SPRING WASHER	SUS316L	7	M12	
13	平圧金 WASHER	SUS316L	7	M12	
12	平圧金 WASHER	POM	7	T-201-11	
11	ステンレスバンド ROSE CLAMP	SUS	2	450-SUS	
10	御面スポンジ CUSHION RUBBER	SILICONE SPONGE	2	02-153-4322	
9	六角ナット HEX.NUT	SUS316L	16	M12	
8	金属ワッシャー WASHER	SUS304	8	02-153-4325	
7	積層防振ワッシャー70 MULTI-PLATE WASHER 70	SUS304/CR	8	02-153-4323	
6	積層防振ワッシャー50 MULTI-PLATE WASHER 50	SUS304/CR	8	02-153-4324	
5	スペーサ (2) SPACER	SGP	7	02-153-4321	
4	押え板2 FIXING PLATE 2	SS400/CR	1	02-153-4317	
3	Tドフラット TRANSUDGER ATTACHMENT	SS400/CR	1	02-153-4315	
2	船底板 HULL PLATE	SS400/CR	1	02-153-4311	
1	送受装置 TRANSUDGER		1	CV-303	

DRAWN	9/Mar/2010 I.YAMASAKI	TITLE	T-625-A
CHECKED	9/Mar/2010 I.TAKAHASHI	名*	分割船底板キット
APPROVED	11/Mar/2010 Y.NISHIYAMA	外寸図	
SCALE	1/8 MASS 92 ±0.05	NAME	TRANSUDGER FIXING PLATE KIT
DWG.No.	C2373-G08-A	REF.No.	02-153-4310-0
			OUTLINE DRAWING

A

B

C

D

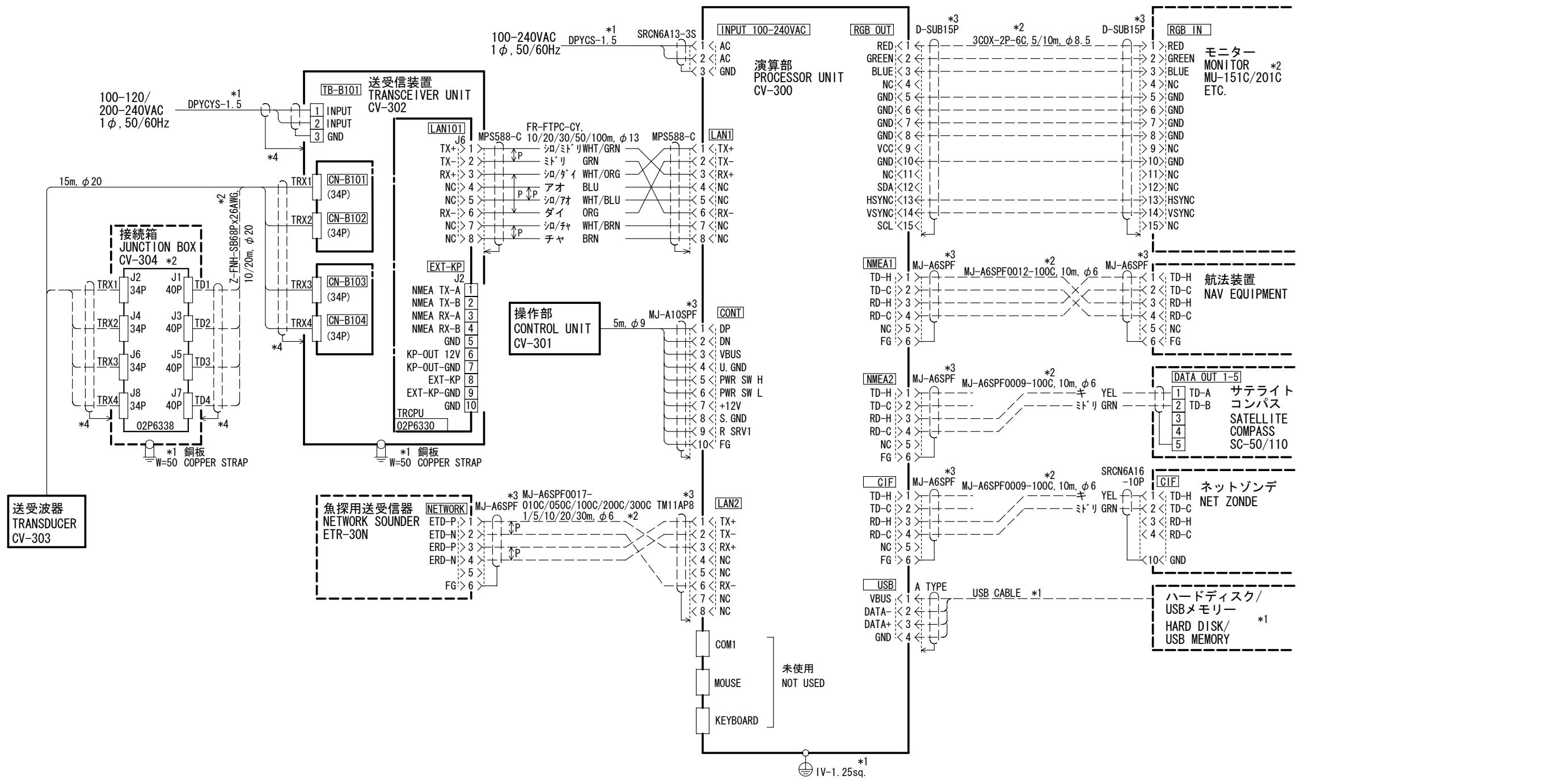

- 注記
- * 1) 造船所手配。
 - * 2) オプション。
 - * 3) コネクタは工場にて取付済み。
 - * 4) ケーブルクランプで接地する。

- NOTE
- *1: SHIPYARD SUPPLY
 - *2: OPTION
 - *3: CONNECTOR PLUG FITTED AT FACTORY.
 - *4: GROUND THROUGH CABLE CLAMP.

DRAWN	Apr. 2 '07 T. YAMASAKI	TITLE	FCV-30
CHECKED	Apr. 2 '07 T. TAKENO	名称	カラー魚群探知機
APPROVED	Apr. 11 '07 R. Esumi		相互結線図
SCALE	MASS kg	NAME	COLOR VIDEO SOUNDER
DWG No.	C2373-C01-F		INTERCONNECTION DIAGRAM