

# FURUNO

# OPERATOR'S MANUAL

## DISTRESS MESSAGE CONTROLLER

**MODEL DMC-5**

**(incl. Installation Instructions)**

**[Applicable to Program Version 4.04 and after]**



**FURUNO ELECTRIC CO., LTD.**  
NISHINOMIYA, JAPAN



(Elemental Chlorine Free)

The paper used in this manual  
is elemental chlorine free.

© **FURUNO ELECTRIC CO., LTD.**

9-52 Ashihara-cho,  
Nishinomiya 662-8580, JAPAN

Telephone : 0798-65-2111

Fax : 0798-65-4200

FURUNO Authorized Distributor/Dealer

All rights reserved.

Printed in Japan

Pub. No. OME-55440

( DAMI ) DMC-5

FIRST EDITION : FEB. 1992

M : AUG. 07, 2002



\* 0 0 0 8 0 3 0 4 6 1 0 \*



\* O M E 5 5 4 4 0 M 0 0 \*



# SAFETY INSTRUCTIONS

"**DANGER**", "**WARNING**" and "**CAUTION**" notices appear throughout this manual. It is the responsibility of the operator of the equipment to read, understand and follow these notices. If you have any questions regarding these safety instructions, please contact a FURUNO agent or dealer.

The level of risk appearing in the notices is defined as follows:



**DANGER**

This notice indicates a potentially hazardous situation which, if not avoided, will result in death or serious injury.





**WARNING**

This notice indicates a potentially hazardous situation which, if not avoided, could result in death or serious injury.



**CAUTION**

This notice indicates a potentially hazardous situation which, if not avoided, could result in minor or moderate injury, or property damage.

 <b>WARNING</b>	
	<p><b>Do not open the equipment.</b></p> <p>Hazardous voltage which can cause electrical shock, burn or serious injury exists inside the equipment. Only qualified personnel should work inside the equipment.</p>
<p><b>Do not disassemble or modify the equipment.</b></p> <p>Fire, electrical shock or serious injury can result.</p>	
<p><b>Turn off the power immediately if water leaks into the equipment or the equipment is emitting smoke or fire.</b></p> <p>Continued use of the equipment can cause fire or electrical shock.</p>	
<p><b>Do not place liquid-filled containers on the top of the equipment.</b></p> <p>Fire or electrical shock can result if a liquid spills into the equipment.</p>	
<p><b>Do not operate the equipment with wet hands.</b></p> <p>Electrical shock can result.</p>	
<p><b>Keep heater away from equipment.</b></p> <p>Heat can alter equipment shape and melt the power cord, which can cause fire or electrical shock.</p>	
<p><b>Any repair work must be done by a licensed radio technician.</b></p> <p>Improper repair work can cause electrical shock or fire.</p>	

 <b>CAUTION</b>
<p><b>Do not touch any part of the antenna when the equipment is transmitting.</b></p> <p>Electrical shock can result.</p>

**⚠ WARNING**

 Do not work inside the equipment unless totally familiar with electrical circuits.

Hazardous voltage which can shock, burn or cause serious injury exists inside the equipment.

 Turn off the power at the mains switchboard before beginning the installation. Post a sign near the switch to indicate it should not be turned on while the equipment is being installed.

Fire, electrical shock or serious injury can result if the power is left on or is applied while the equipment is being installed.

**⚠ CAUTION**

 Ground the equipment.

Ungrounded equipment can give off or receive electromagnetic interference or cause electrical shock.

**Confirm that the power supply voltage is compatible with the voltage rating of the equipment.**

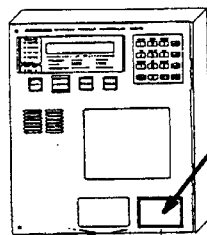

Connection to the wrong power supply can cause fire or equipment damage. The voltage rating appears on the label at the rear of the equipment.

**WARNING Label attached**



**⚠ WARNING ⚠**

To avoid electrical shock, do not remove cover. No user-serviceable parts inside.

 — — 

-----

-----

-----

Name : Warning Label (1)  
 Type : 86-003-1011-0  
 Code No. : 100-236-230

# INSTRUCTIONS FOR CANCELLING A FALSE DISTRESS ALERT

## DSC MF

1. Switch off equipment immediately.
2. Switch equipment on and tune for radiotelephony transmission on 2, 182 kHz.
3. Make broadcast to "All Stations" giving the vessel's name, callsign and DSC number, and cancel the false distress alert.

### Example message:

All Stations, All Stations, All Stations  
This NAME, CALLSIGN,  
DSC NUMBER, POSITION.

Cancel my distress alert of  
DATE, TIME, UTC.  
=Master, NAME, CALLSIGN,  
DSC NUMBER, DATA, TIME UTC.

## DSC HF

Same as for MF but the alert must be cancelled on all the frequency bands on which it was transmitted. Hence, in stage 2.2 the transmitter should be tuned consecutively to the radiotelephony distress frequencies in the 4, 6, 8, 12 and 16 MHz band, as necessary.

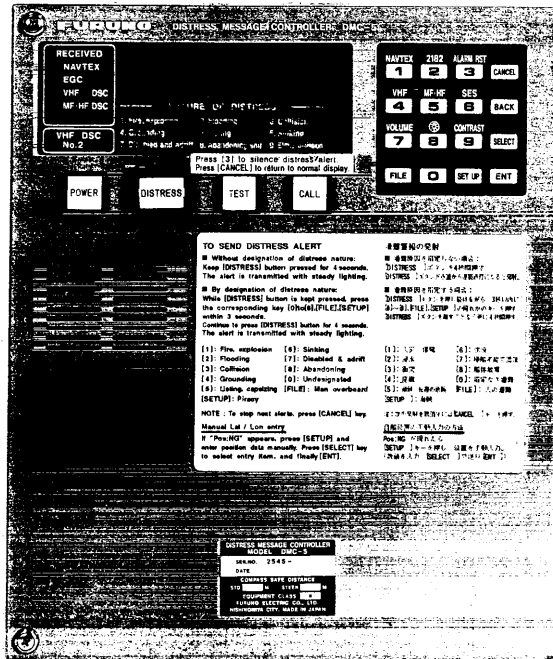

T Photo No.1279

DMC-5 Distress Message Controller (Bulkhead Mount)

# Table of Contents

	<u>page</u>
<b>1. INTRODUCTION AND CONTROL DESCRIPTION</b> .....	<b>1</b>
1.1 What is the DMC-5 .....	1
1.2 Basic Operation .....	2
1. Default Display .....	2
2. Selecting Items on the LCD .....	2
1.3 Switches .....	3
1.4 Keys .....	4
<b>2. TRANSMISSION OF DISTRESS CALL</b> .....	<b>6</b>
2.1 Undesignated Nature of Distress .....	6
2.2 Designated Nature of Distress .....	8
2.3 Receiving Distress Relay .....	11
<b>3. RECEIVING DISTRESS CALL</b> .....	<b>12</b>
3.1 Receiving Distress Call .....	12
3.2 Transmitting Distress Acknowledge (VHF DSC/MF DSC only) .....	13
3.3 Relaying Distress Call (HF DSC only) .....	15
3.4 Viewing Date and Time of Distress Calls Received .....	17
3.5 Viewing the Contents of a Distress Message (DSC only) .....	18
<b>4. CHANGE OF SETTINGS</b> .....	<b>19</b>
4.1 Date and Time .....	19
4.2 Alarm Tone Selection and Keyboard Response Tone ON/OFF ..	20
4.3 Switching to No.2 VHF (No.1 VHF failure) .....	22



<b>5. MAINTENANCE</b> .....	<b>23</b>
5.1 Regular Maintenance .....	23
Location of PCBs .....	25
5.2 Self Test .....	26
5.3 Troubleshooting (For qualified personnel) .....	32
5.4 Displaying ROM Version Number .....	34
<b>6. INSTALLATION (For qualified personnel)</b> .....	<b>35</b>
6.1 Mounting Location .....	35
6.2 Bulkhead Mounting .....	35
6.3 Flush Mounting .....	36
6.4 Connections .....	37
<b>7. SYSTEM SETTINGS</b> .....	<b>38</b>
7.1 Equipment ON/OFF .....	38
1. NAVTEX Receiver .....	38
2. VHF DSC .....	39
3. MF/HF DSC .....	40
4. Inmarsat C SES/EGC Receiver .....	41
7.2 Alarm Tone Selection .....	42
7.3 Date and Time .....	44
<b>8. MANUAL INPUT OF SHIP'S POSITION</b> .....	<b>46</b>
Specifications .....	AP1 – 1
Complete Set/Installation Materials .....	AP1 – 3
Outline Drawing .....	D – 1
Interconnection Diagrams/Schematic Diagrams .....	S – 1

# 1. INTRODUCTION AND CONTROL DESCRIPTION

## 1.1 What is the DMC-5?

The FURUNO DMC-5 Distress Message Controller automatically commands all GMDSS communication equipment connected to it (VHF DSC, MF/HF DSC, Inmarsat C SES) to transmit the distress alert on GMDSS distress frequencies, by peeling off the red seal and pressing the **DISTRESS** switch. Then, after receiving a distress acknowledge message from a coast station, the operator can initiate distress communications by radiotelephone. It is primarily designed for use on vessels which operate in ocean areas A3 and A4 and installed on the bridge for convenient operation. Besides its primary function, the DMC-5 also monitors all equipment connected to it for distress alert calls, transmits distress acknowledge calls (VHF DSC, MF DSC only), relays distress calls (HF DSC only).

### Example: A3 ocean area-going vessel

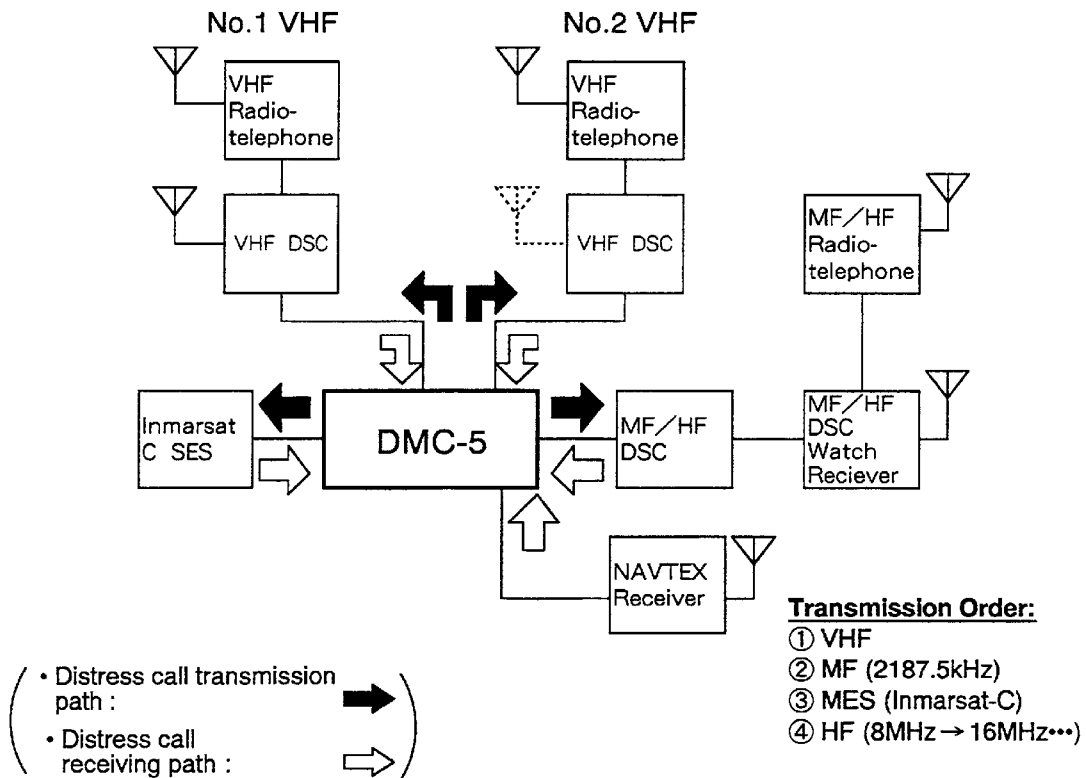

Note: A DSC-equipped VHF radiotelephone is also available.

## 1.2 Basic Operation

This section explains basic key operation conventions.

### 1. Default Display

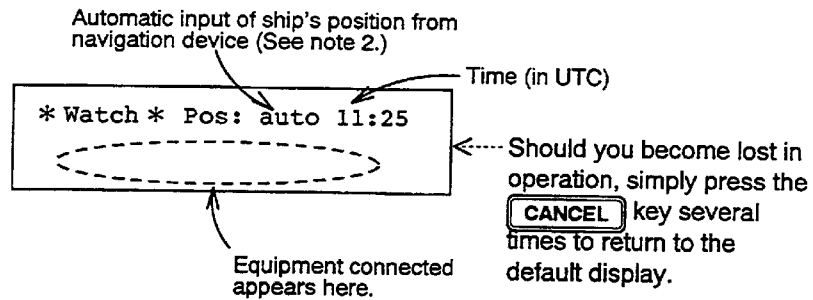

Note 1: For sake of brevity, the default display shown throughout this manual excludes the indications of the time, auto position input and equipment connected.

Note 2: Ship's position can be input manually in case of navigation equipment failure. Refer to chapter 8 for further details.

### 2. Selecting items on the LCD

(Example: self test display)

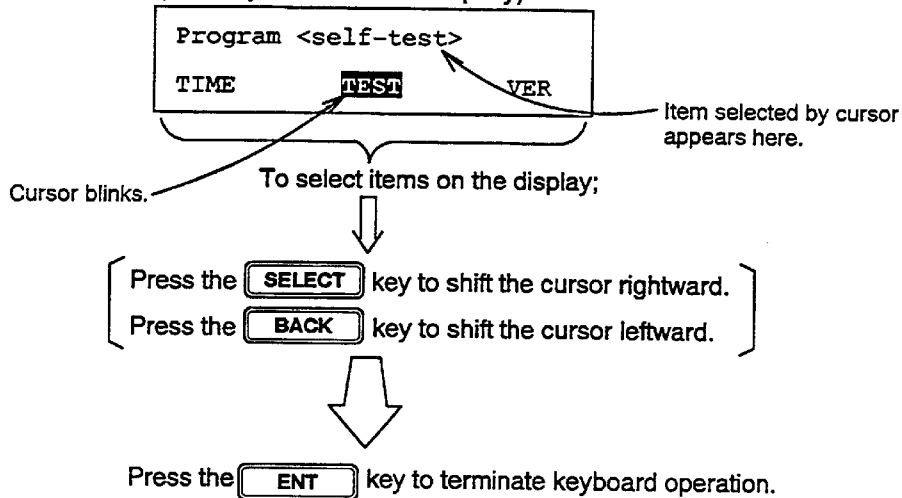

### = IMPORTANT =

During transmission of a message ( **DISTRESS** or **CALL** pressed), **the DSC and transceiver accept no key input.** ("Remote DMC" appears on the screen of the DSC.)

The keys of the radiotelephone will be unlocked when a message transmission has been completed and the DMC-5 has moved to "Wait for dist ack" state.

## 1.3 Switches

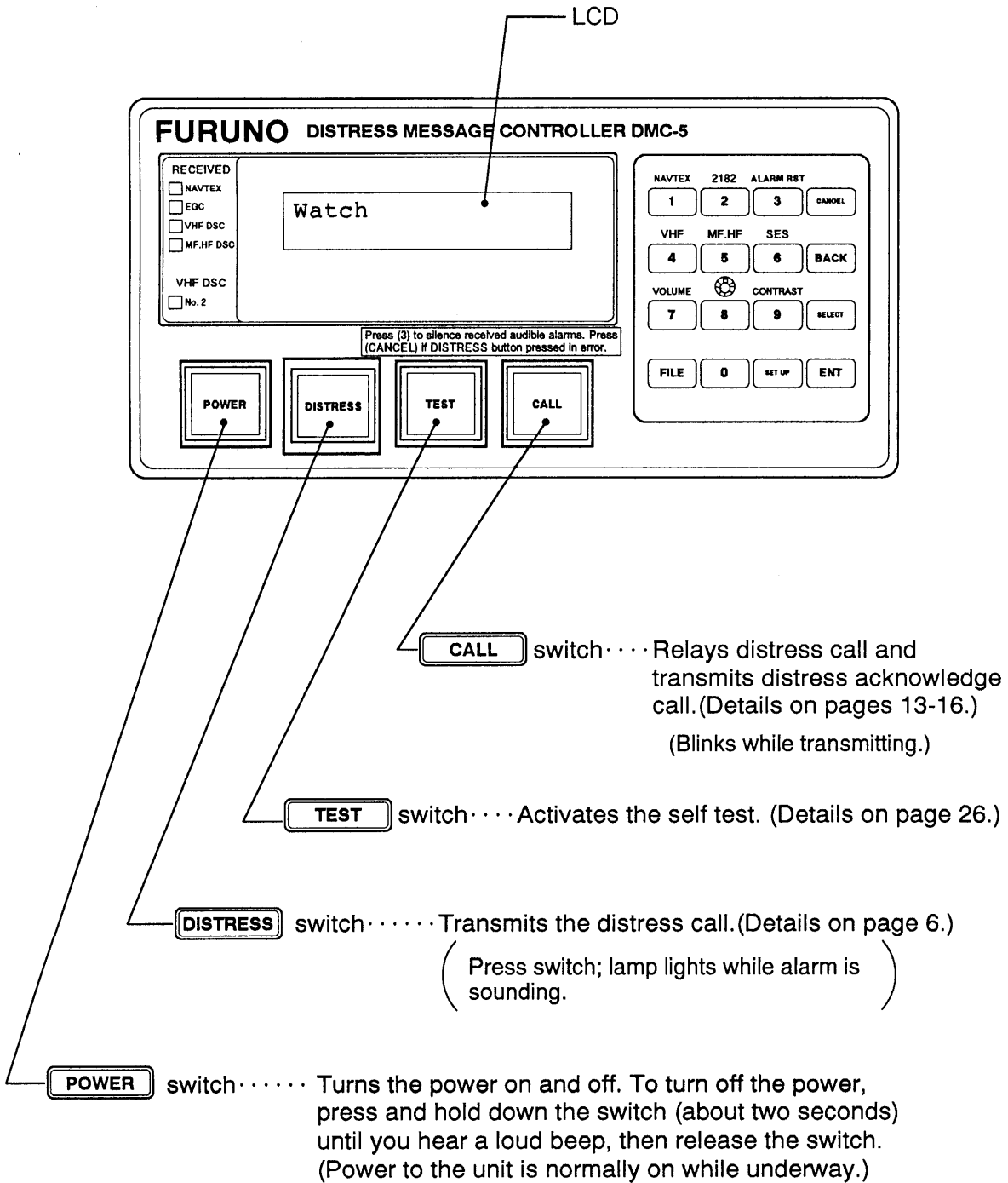



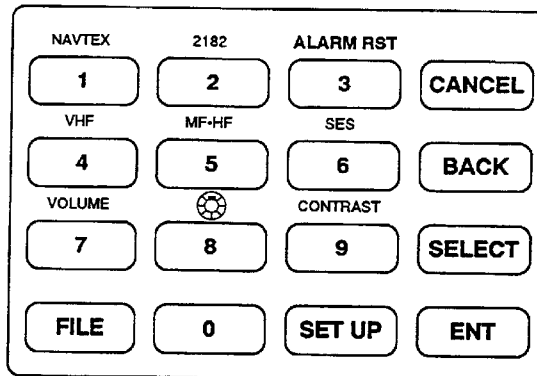

## 1.4 Keys











Key	Function	Remarks
~	Entering numeric data.	
	Cancels data.	Several presses can return control to the default display.
	Shifts the cursor leftward.	For selection of items on the LCD.
	Shifts the cursor rightward. Calls program menu. (Date/time entry and self test selection)	For selection of items on the LCD.
	Registers selection made with  and  keys.	For entering items on the LCD.
NAVTEX 	Displays date and time of distress messages (max. 50) received by NAVTEX receiver.	Details on page 17
VHF 	Displays date, time and contents of distress messages (max. 50) received by VHF DSC receiver.	
MF·HF 	Displays date, time and contents of distress messages (max. 50) received by MF/HF DSC receiver.	
SES 	Displays date and time of distress messages (max. 50) received by EGC receiver or Inmarsat C SES.	
ALARM RST 	Silences receive alarm.	

(continued on next page)

Key	Function
<b>VOLUME</b> 	Adjusts speaker volume in eight levels. Note however that the receive alarm sounds at maximum volume regardless of <b>VOLUME</b>  control setting.
	Adjusts the illumination of the LCD, keyboard and switches in four levels.
<b>CONTRAST</b> 	Adjusts LCD contrast in eight levels.
	Not used.

### The key

The  key mainly enables equipment selection/deselection when pressed with other keys. Press the  key then press desired key within 2-3 seconds.

Key combination	Function	Reference page
 ⇒ (“SET UP” displayed on LCD.)	<b>NAVTEX</b> 	NAVTEX Receiver selection/deselection. 38
	<b>VHF</b> 	VHF DSC Receiver selection/deselection. 39
	<b>MF·HF</b> 	MF/HF DSC Receiver selection/deselection, and selects class of emission for distress communications. 40
	<b>SES</b> 	Inmarsat C SES selection/ deselection. 41
	<b>VOLUME</b> 	Turns on and off keyboard response tone and selects receive alarm tone. 42

# 2. TRANSMISSION OF DISTRESS CALL

## 2.1 Undesignated Nature of Distress

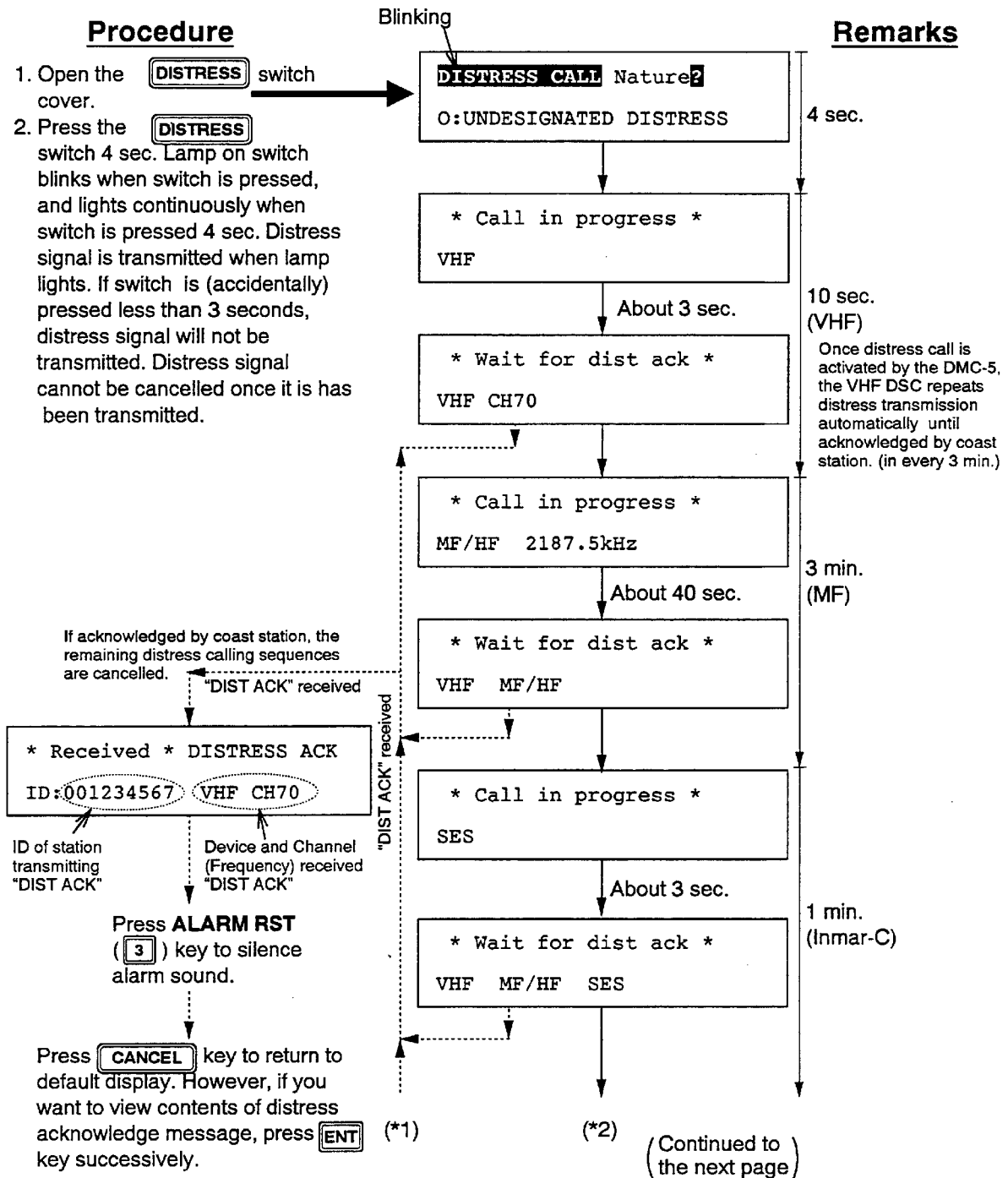

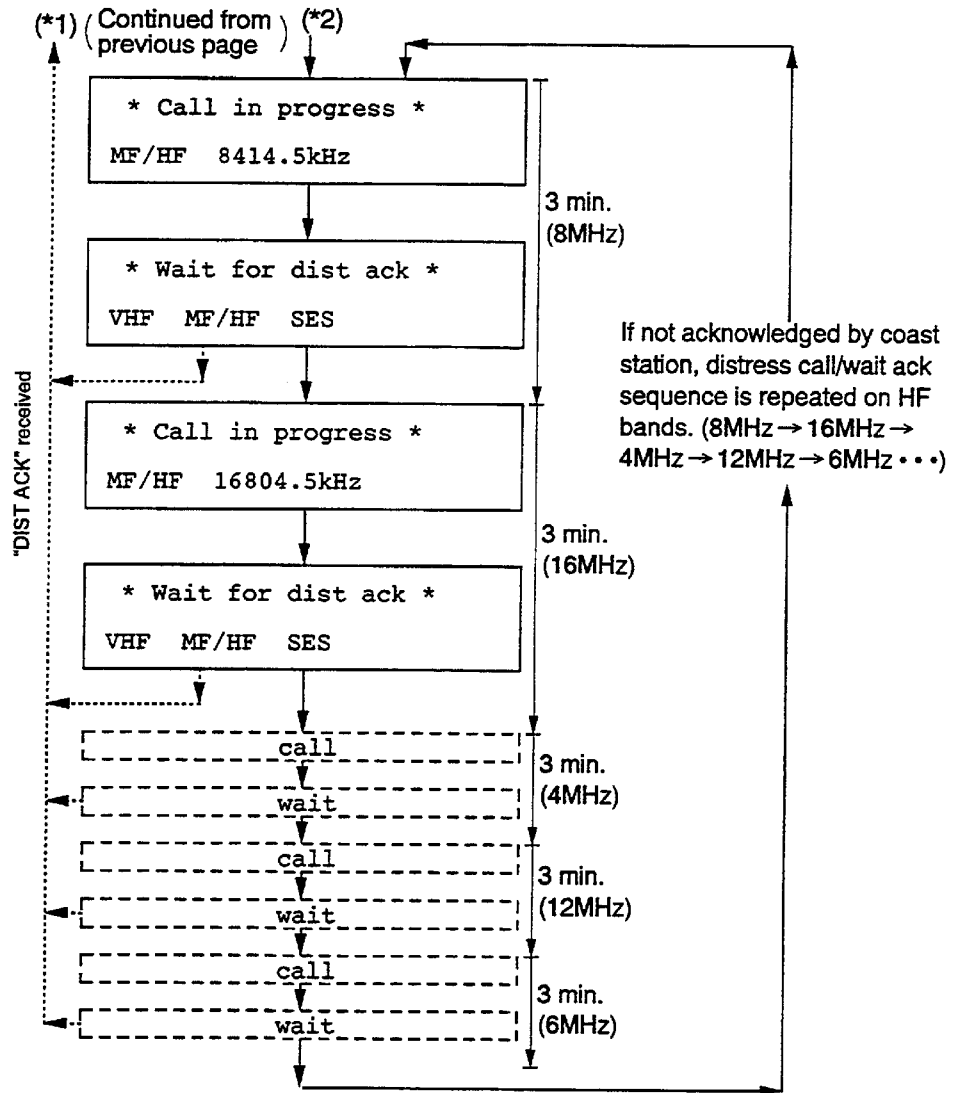

**Contents of distress message**

- ( VHF DSC ) : ① Nature of distress (Undesignated)
- ( MF/HF DSC ) : ② Class of emission set on DMC-5 (Tel. or Telex)... See page 41.
- For VHF, simplex tel.
- ③ Own ship's ID, time
- ④ Ship's position
- Even though the message is acknowledged by another ship, the message is transmitted until acknowledged by coast station.
- Inmarsat-C SES : ① Nature of distress (Undesignated)
- ② Own ship's ID, time
- ③ Own ship's position, speed and heading

To confirm distress message contents, conduct the self test described on page 26.



## 2.2 Designated Nature of Distress

1. Open the **DISTRESS** switch cover.
2. Press **DISTRESS** switch continuously and press appropriate key (0 – 8) within 3 seconds.
3. Continue pressing **DISTRESS** switch at least 4 seconds. Lamp on switch blinks when switch is pressed, and lights continuously when the distress signal is transmitted.

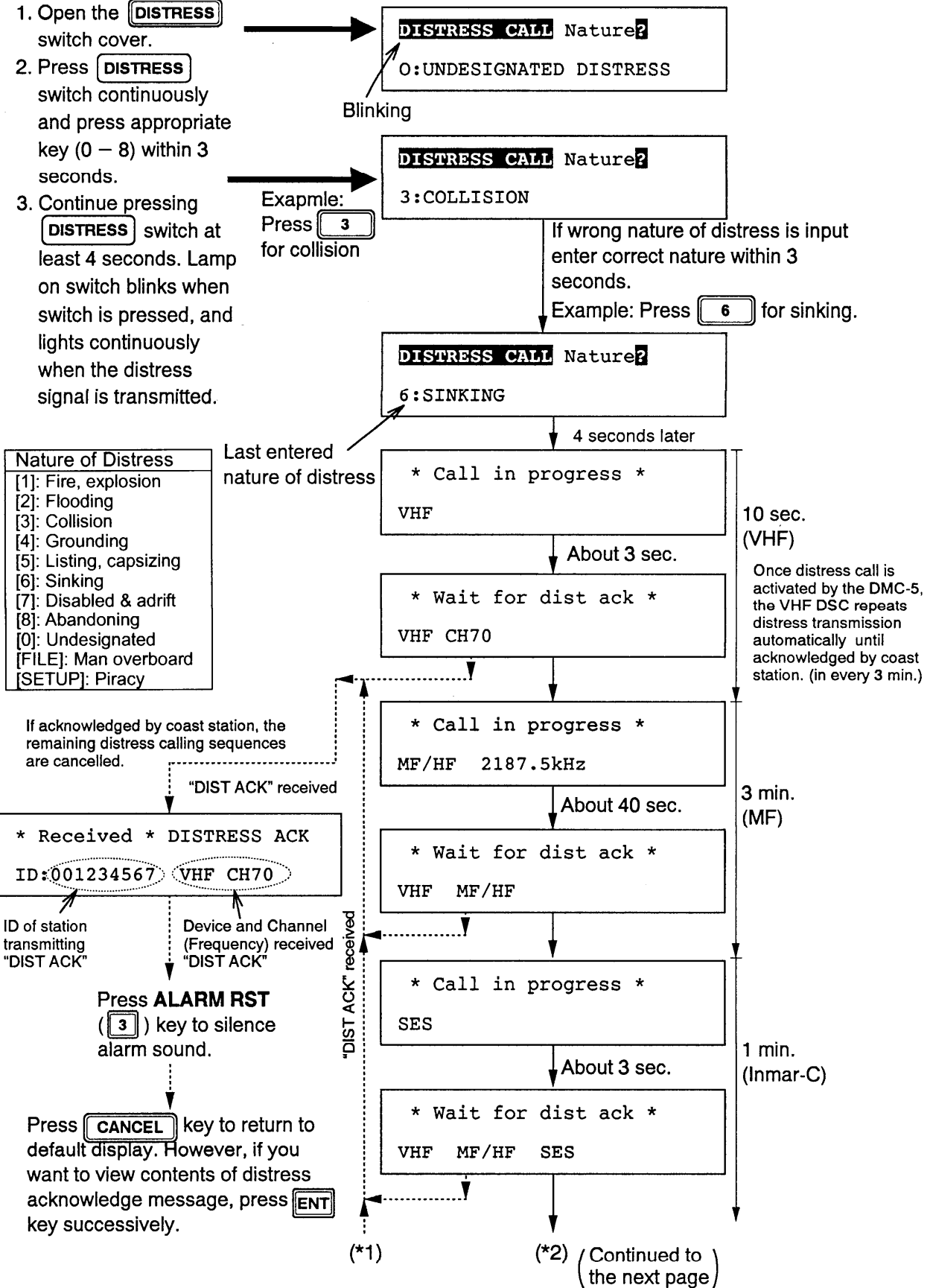

2. TRANSMISSION OF DISTRESS CALL

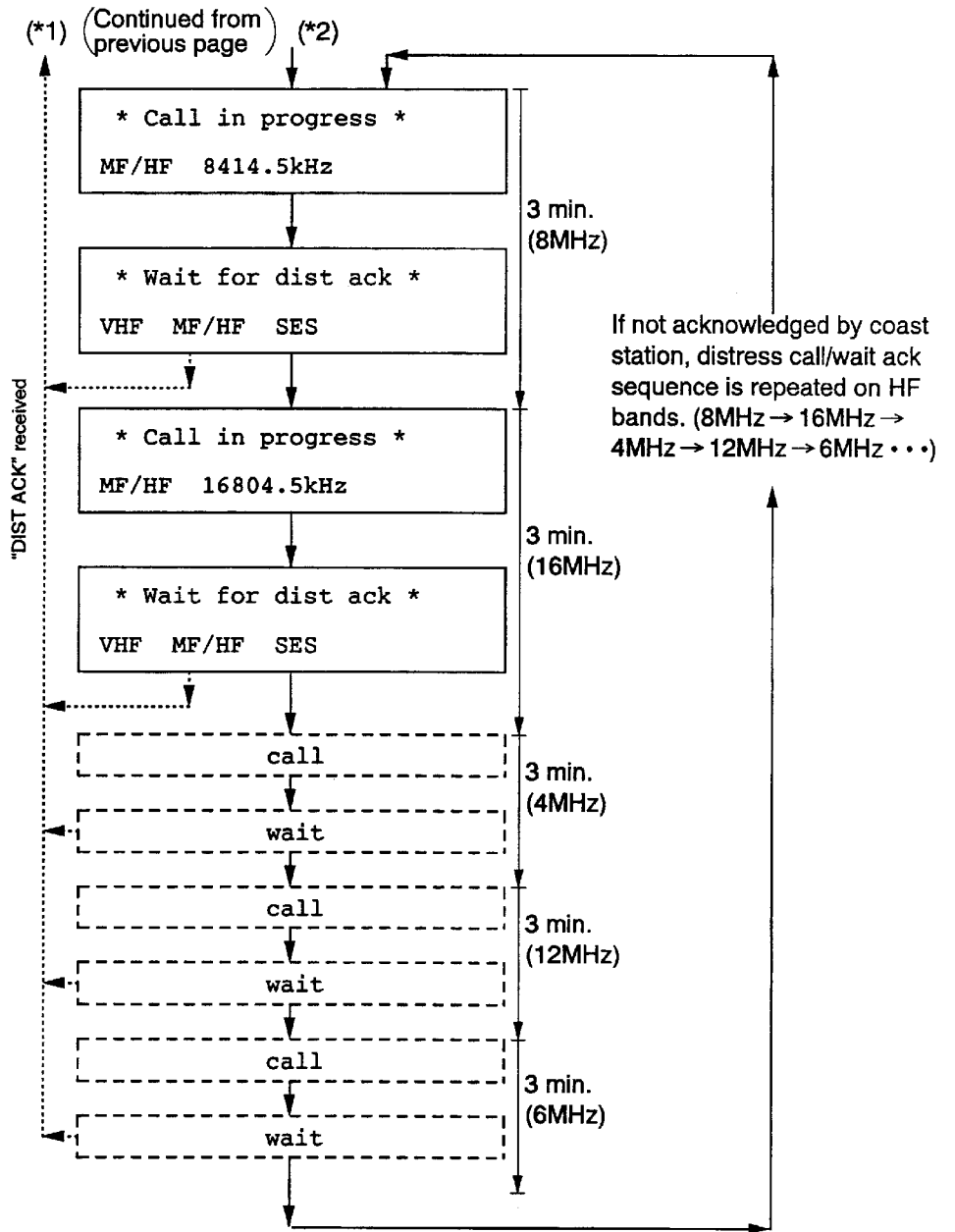

**Contents of distress message**

- ( VHF DSC ) : ① Nature of distress set on DMC-5.  
  ( MF/HF DSC ) ② Class of emission set on DMC-5 (Tel. or Telex)... See page 41.  
                            For VHF, simplex tel.
- ③ Own ship's ID, time
- ④ Ship's position
- Even though the message is acknowledged by another ship, the message is transmitted until acknowledged by coast station.
- Inmarsat-C SES : ① Nature of distress (Undesignated)
- ② Own ship's ID, time
- ③ Own ship's position, speed and heading

To confirm distress message contents, conduct the self test described on page 26.

## 2.3 Receiving Distress Relay

When you receive a distress relay (all ships call only) from another ship, the display looks something like the one shown below.

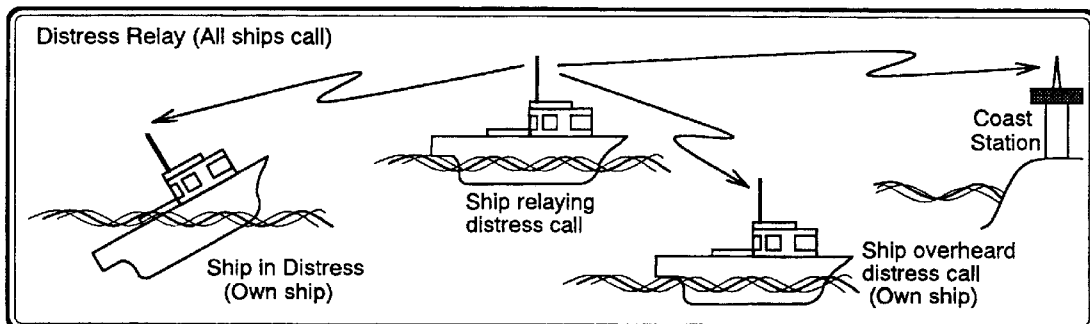
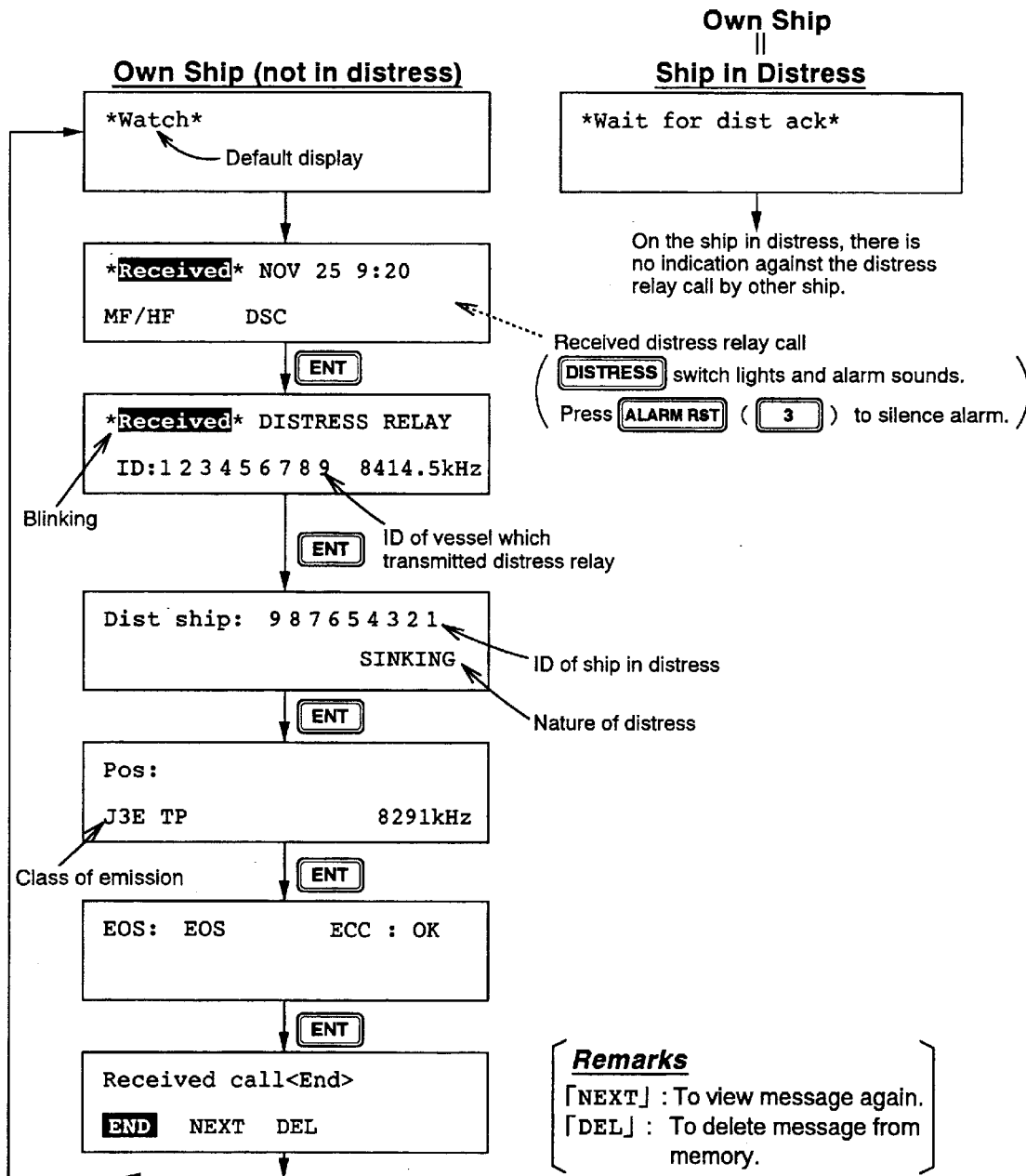

# 3. RECEIVING DISTRESS CALL

## 3.1 Receiving Distress Call

When you receive a distress call the display should look something like the one shown below and the alarm sounds. You can silence the alarm with the **[ALARM RST]** (**3**) key. (This action also silences the alarm emitted by the DSC.)

**Example: distress call received on VHF DSC**

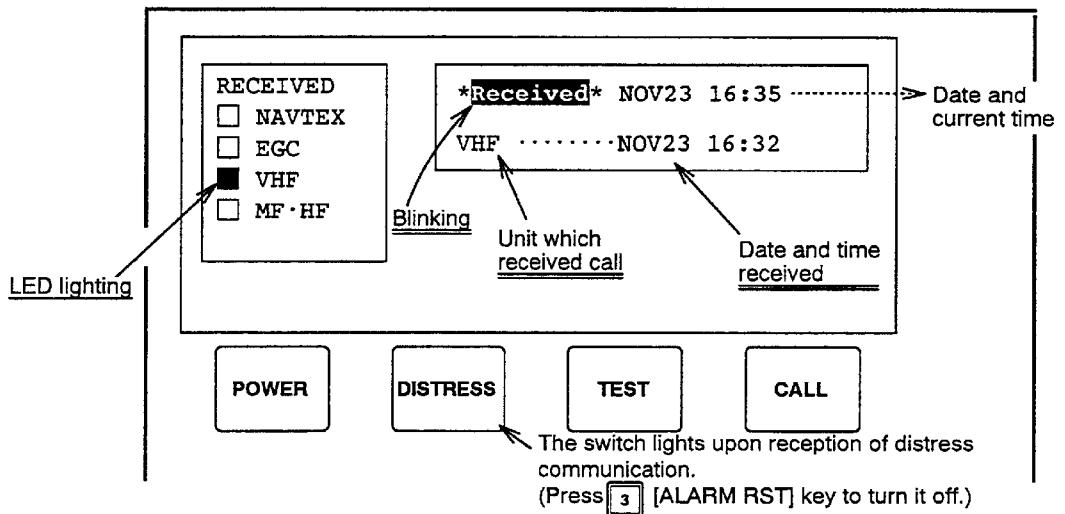

Other equipment which received the distress call appear on the LCD. The LEDs on the left-hand side of the panel also show this information. (No LED is provided for 2182WR.)

**Example: VHF DSC → MF/HF DSC → EGC receive distress call in that order.**

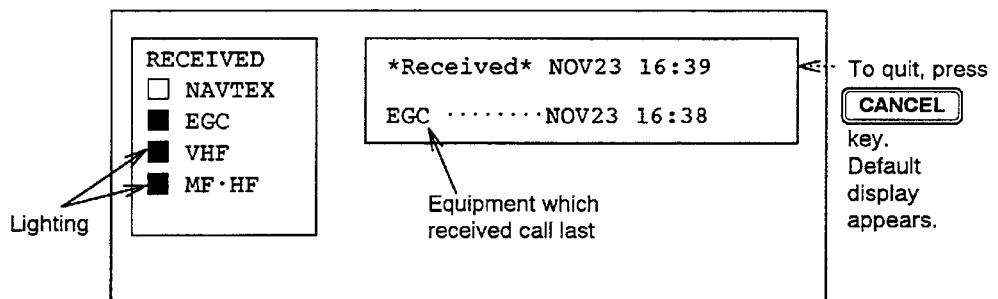

(To turn off the LED "NAVTEX", press the **[CANCEL]** key. For LEDs "VHF" and "MF·HF", they go off only when you view the contents of distress message. Refer to page 18 for further details.)

## 3.2 Transmitting Distress Acknowledge (VHF DSC/MF DSC only)

Your vessel can transmit the distress acknowledge only in the following circumstances.

If you receive a distress call on a frequency band other than HF;

- ① For A1 and A2 ocean areas where it is possible to communicate with coast station

Wait a reasonable amount of time for the coast station to transmit the distress acknowledge to the ship in distress. If the coast station does not respond, first try to transmit the distress acknowledge to ship in distress by radiotelephone. If it does not succeed, transmit it by the DMC-5.

- ② A3 and A4 ocean areas where it may not be possible to communicate with coast station

If the ship in distress is near own ship and obviously cannot communicate with the coast station on the frequency it called on, your vessel should first try to transmit the distress acknowledge to ship in distress by radiotelephone. If not successful, transmit it by the DMC-5. After transmitting the distress acknowledge, relay the distress call to coast station on HF band.

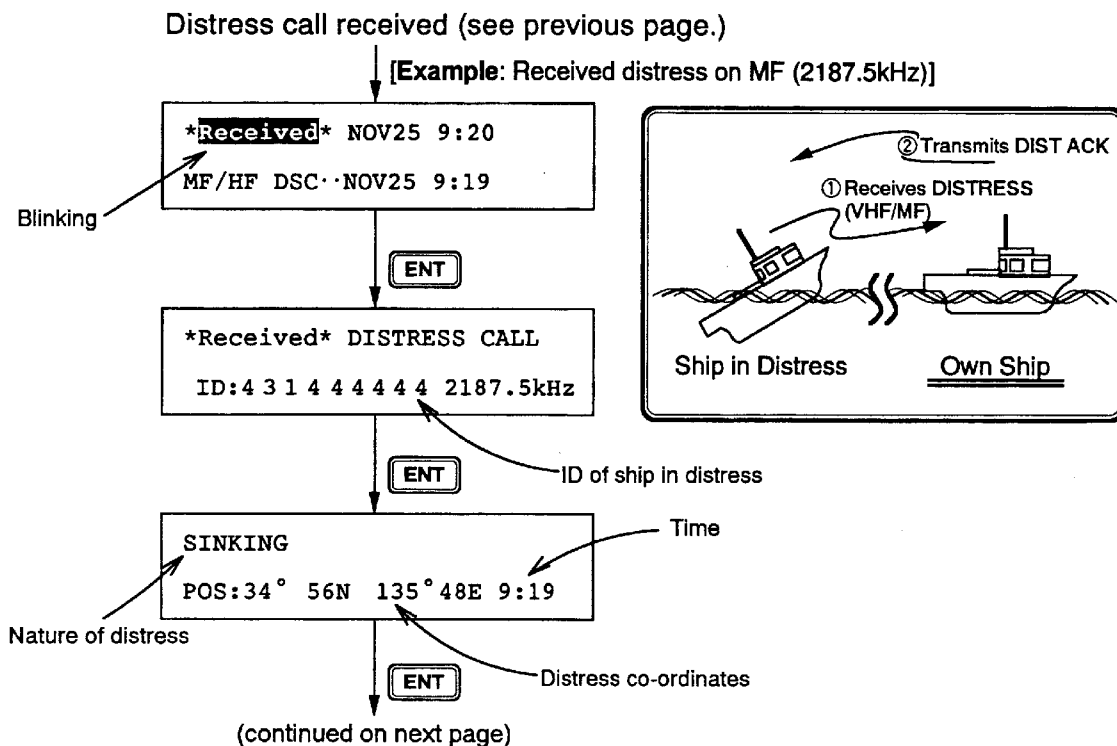

(Continued from previous page)

J3E TP	2182kHz
EOS:EOS	ECC:OK

(For VHF, SIMPLEX and CH70)

Press **ENT**.

Acknowledge call< >			
<b>ACK</b>	RELAY	END	DEL

**Remarks**

- [RELAY]: Relay distress call. (details on page 15)
- [END] : Return to default display.
- [DEL] : Delete message from memory.

Place cursor on **ACK**.  
Press **ENT**.

*Ready for calling*
DIST ACK CALL

Press **CALL** switch.

Wait a reasonable amount of time before sending distress ack call. (Do not press the switch if acknowledged by coast station.)

*Wait for dist ack*
ACK 2187.5kHz <b>0.9</b> min

Blinking and counting down. (MF only. For VHF, acknowledge transmitted immediately.)

When count reaches 0.0 min, DIST ACK sent to ship in distress. If the call is acknowledged by a coast station before the timer reaches terminal count, this sequence is cancelled and control is returned to previous display.

*Call in progress*
DIST ACK CALL

(Now transmitting)

Default display appears.

### 3.3 Relaying Distress Call (HF DSC only)

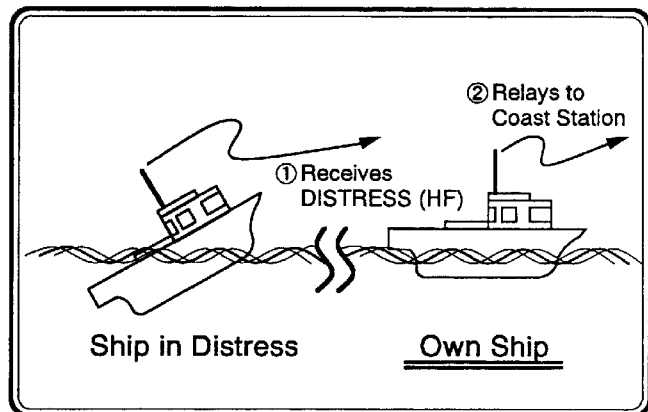
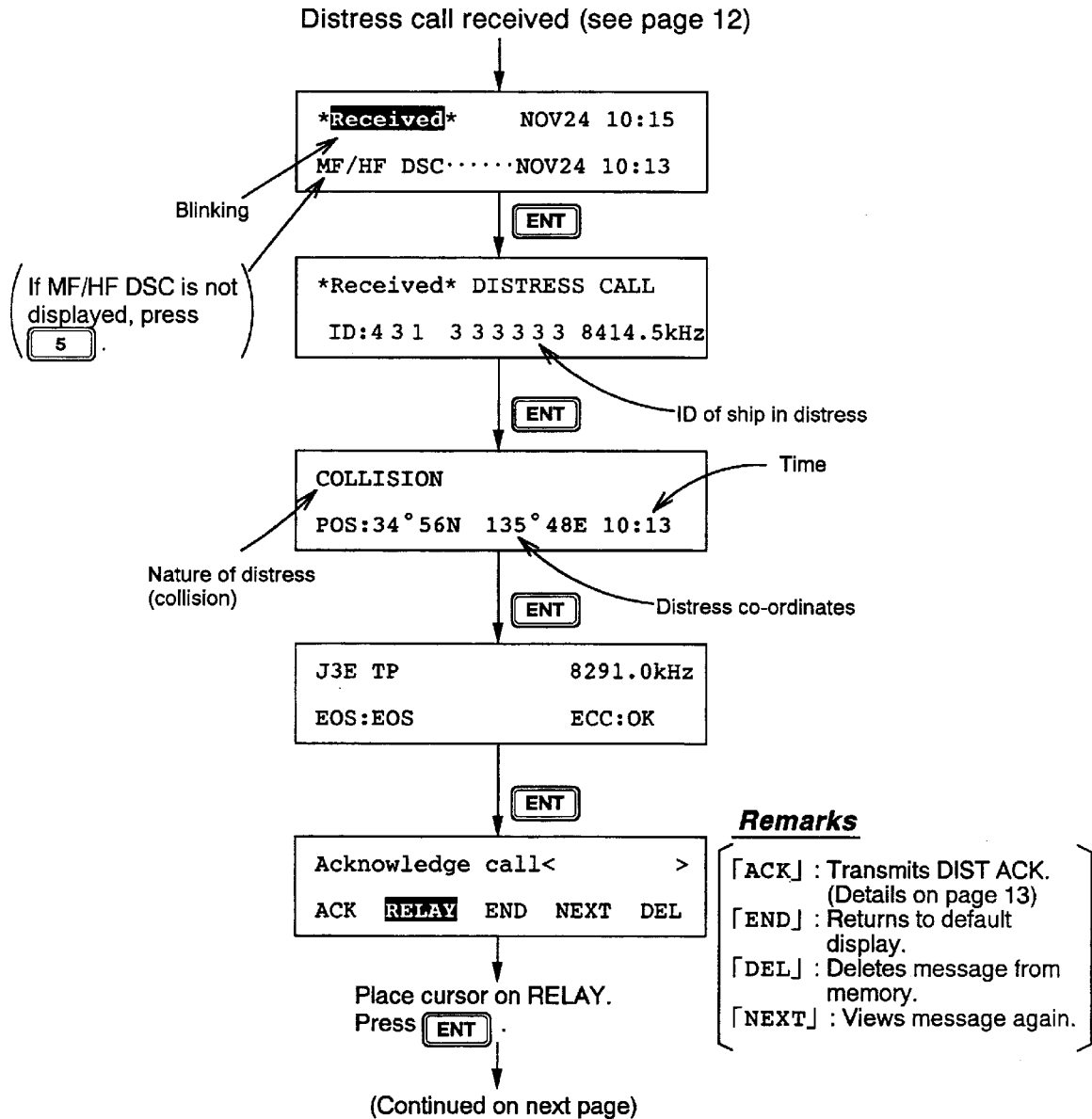



(continued from previous page)

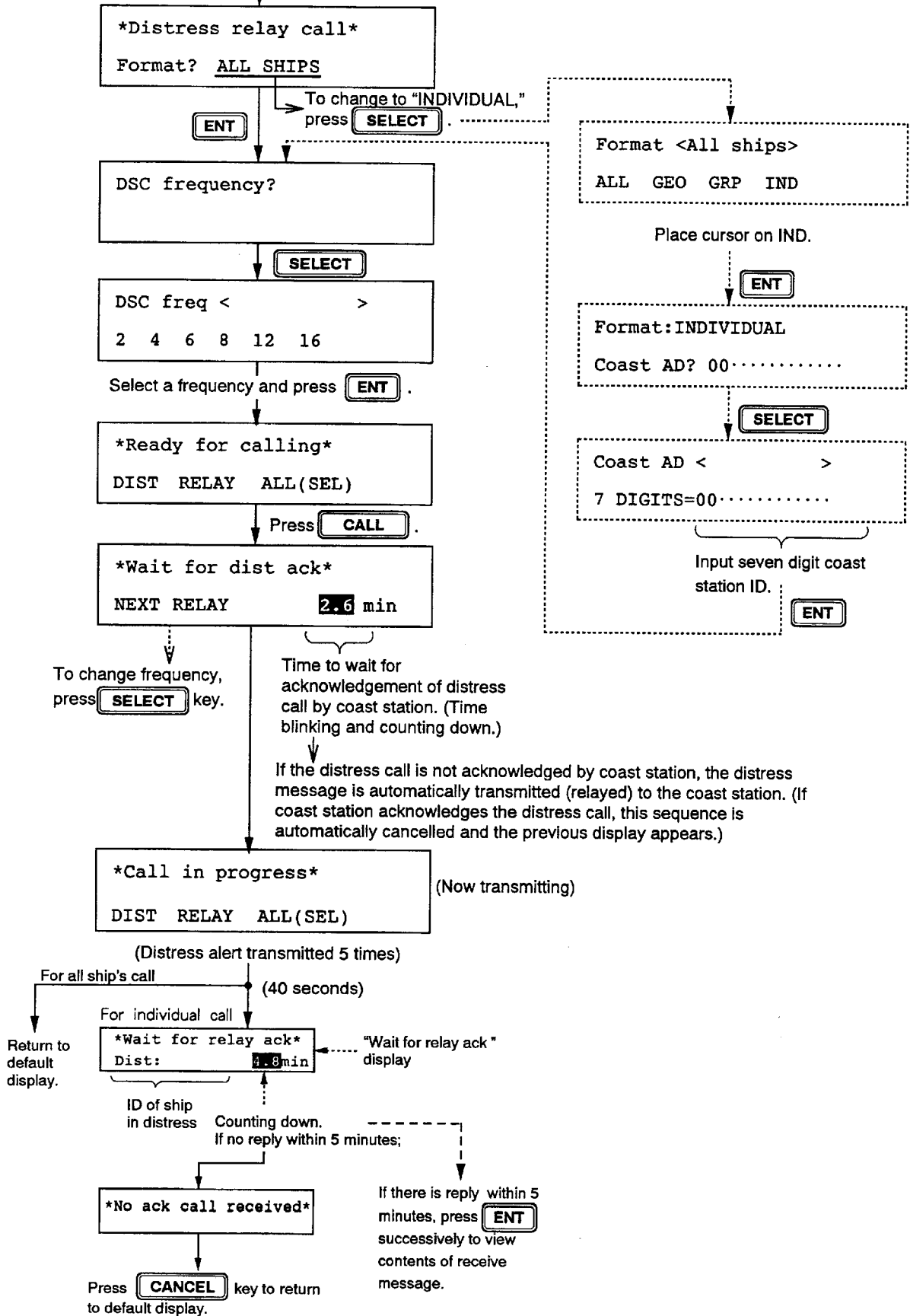

## 3.4 Viewing Date and Time of Distress Calls Received (opening receive log file)

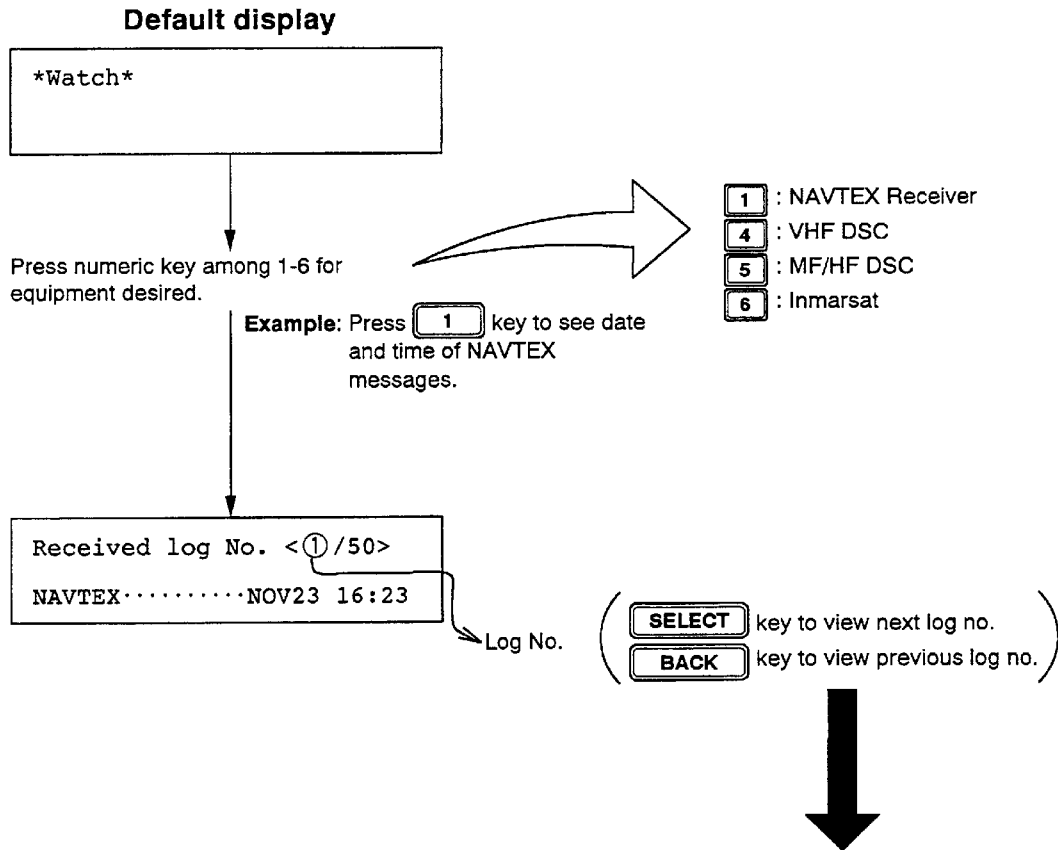

S-RAMs in the DMC-5 store the date and time of up to 50 distress messages received from each unit connected (max. 250 msgs.), on a first-in, first-out basis. This means each time the unit receives a distress message it saves it as log no.1 and changes the log no. of all previously received messages by one. When the memory is full the oldest file is deleted.

## 3.5 Viewing the Contents of a Distress Message (DSC only)

You can view the contents of a distress message received by DSC terminal (Max. 50 msgs. each)

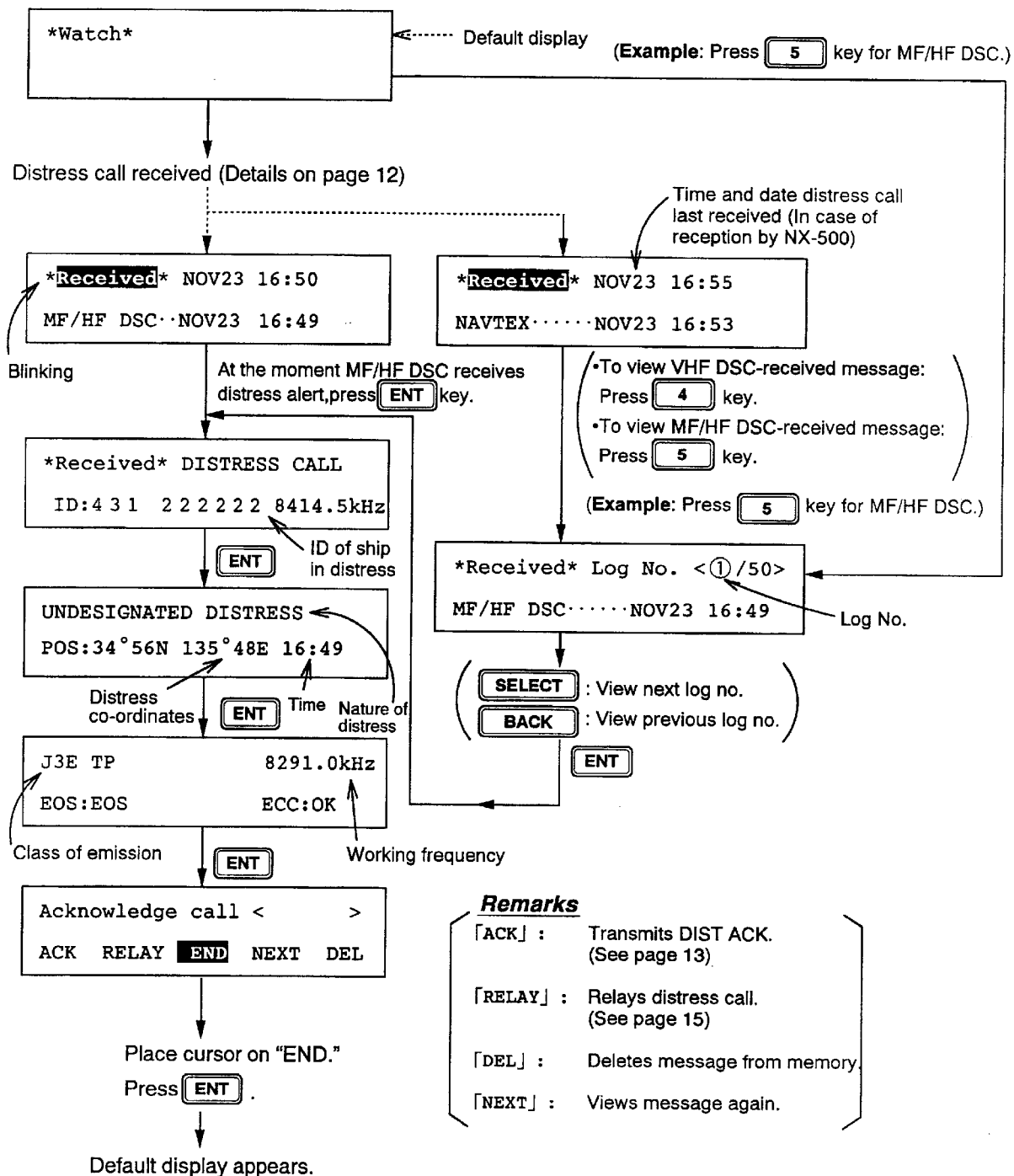

# 4. CHANGE OF SETTINGS

## 4.1 Date and Time

The date and time (UTC) are normally entered during installation, but you can reenter them when necessary. (Always reenter time and date if the power is off for more than about one month). Note that time and date entered through the DMC-5 supersedes those of DSC.

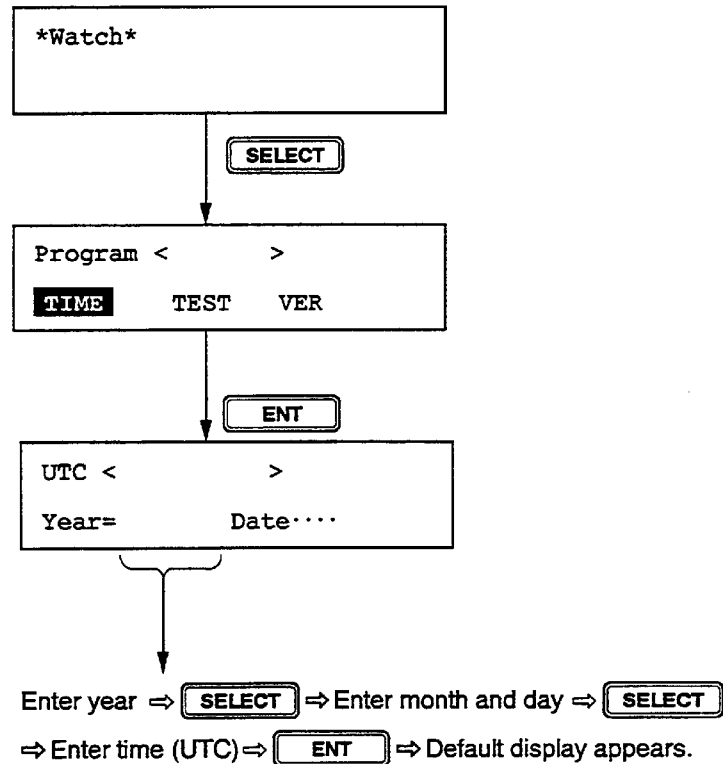

**(Example)** Enter August 1, 1997, 16:00.

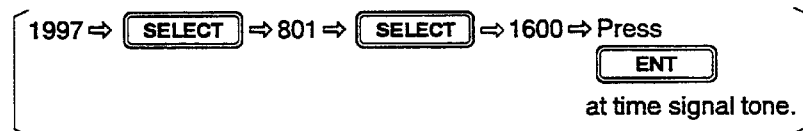

## 4.2 Alarm Tone Selection and Keyboard Response Tone ON/OFF

The user can select receive alarm tone and turn keyboard response tone on or off. These are normally done at installation, but you may change them to suit your needs.

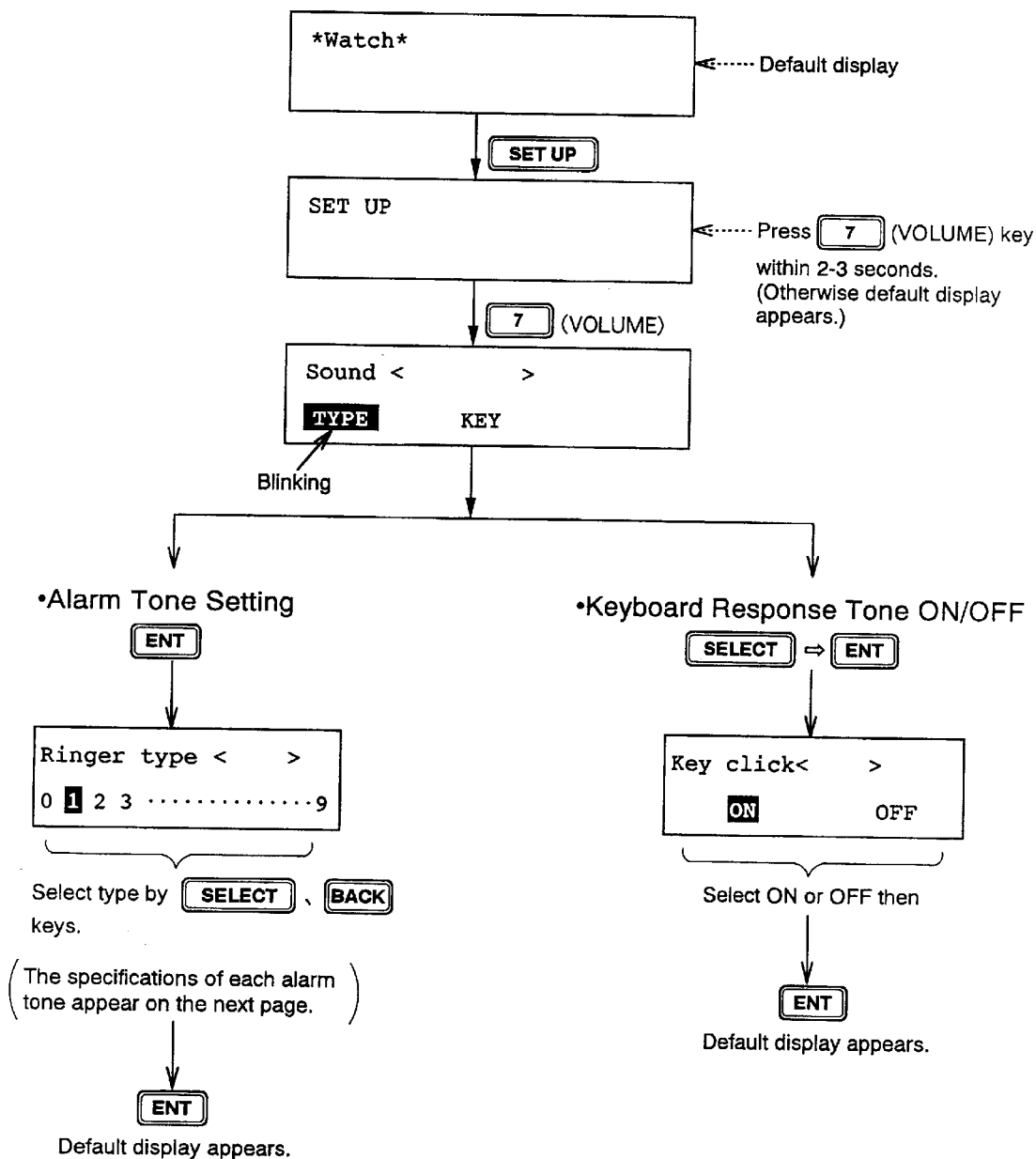

#### 4. CHANGE OF SETTINGS

Ringer type	Specification	
	Tone (Hz)	Interval (ms)
0	2200	Continuous
1	1300 and 2200	250
2	1300 and 2200	125
3	3290	Continuous
4	1945 and 3290	250
5	1945 and 3290	125
6	1100	Continuous
7	650 and 1100	250
8	650 and 1100	125
9	2200 and 0	250

**(Note)** Key response tone frequency is 1800Hz (50ms).

The distress alarm (five seconds duration) frequencies are 2200Hz and 0Hz (interval : 125ms). These frequencies cannot be changed.

## 4.3 Switching to No.2 VHF (No.1 VHF failure)

Normally the No.1 VHF is used. In case of No.1 failure switch to the No.2 VHF, by following the procedure below.

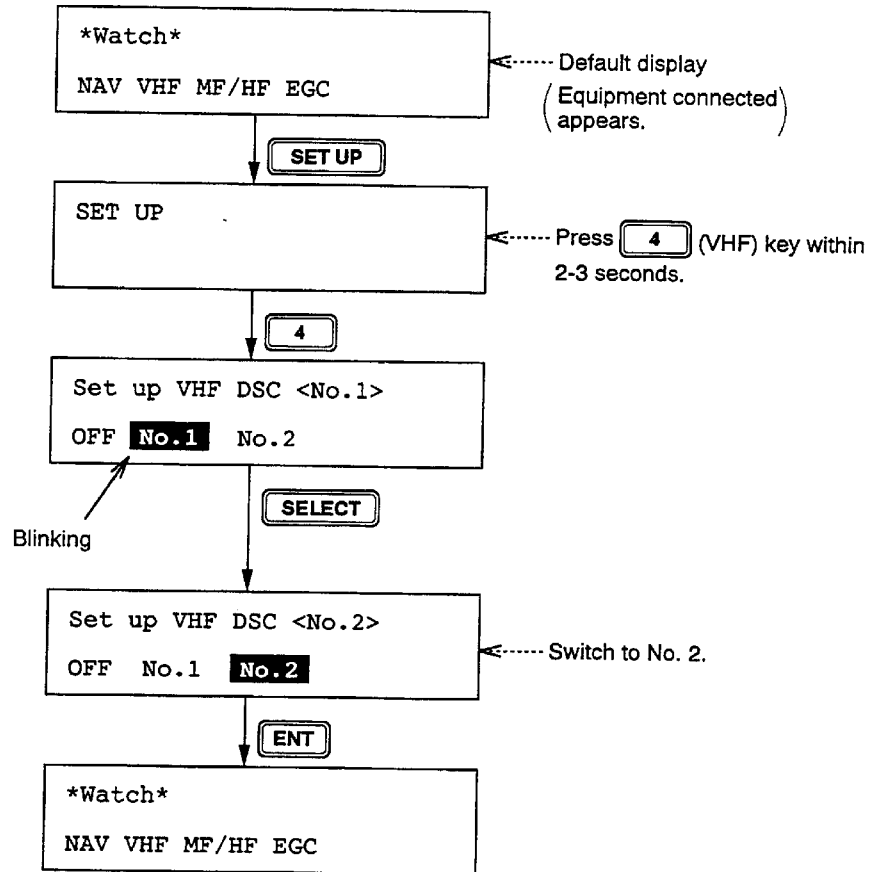

- The "NO. 2" LED on the front panel lights.

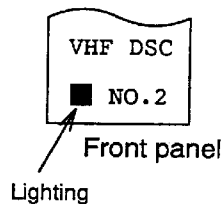

# 5. MAINTENANCE

## 5.1 Regular Maintenance

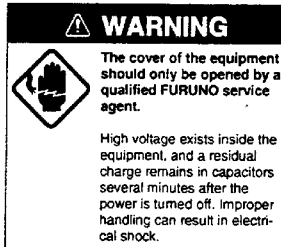

The DMC-5 is designed to provide many years of trouble-free performance. However, no machine can perform its intended function unless properly maintained.

### 1. Cleaning

The external surfaces including the LCD can be cleaned when necessary. The only recommended cleaning article is a soft cloth. Take special care when cleaning the LCD to prevent scratching.

### 2. Checking terminal boards and connectors for tightness (For qualified personnel)

The interconnection cables from external equipment are terminated inside the DMC-5. Check these cables and connectors inside the unit every six months for proper seating.

### 3. Ni-cd battery (For qualified personnel)

The Ni-cd battery on the CONTROL board preserves the memory contents (receive messages, own ship's position data and time data) for about five years. To be sure important information will not be lost, periodically check battery voltage. It should be at least 3.6 V with the power turned off.

*Note :* The unit automatically erases the memory contents if the power is off for about one month.

#### Procedure

1. Cut jumper JP3 on the CONTROL board.
2. Remove discharged battery.
3. Install new battery (Code no. 000-835-126).
4. Install new jumper JP3.



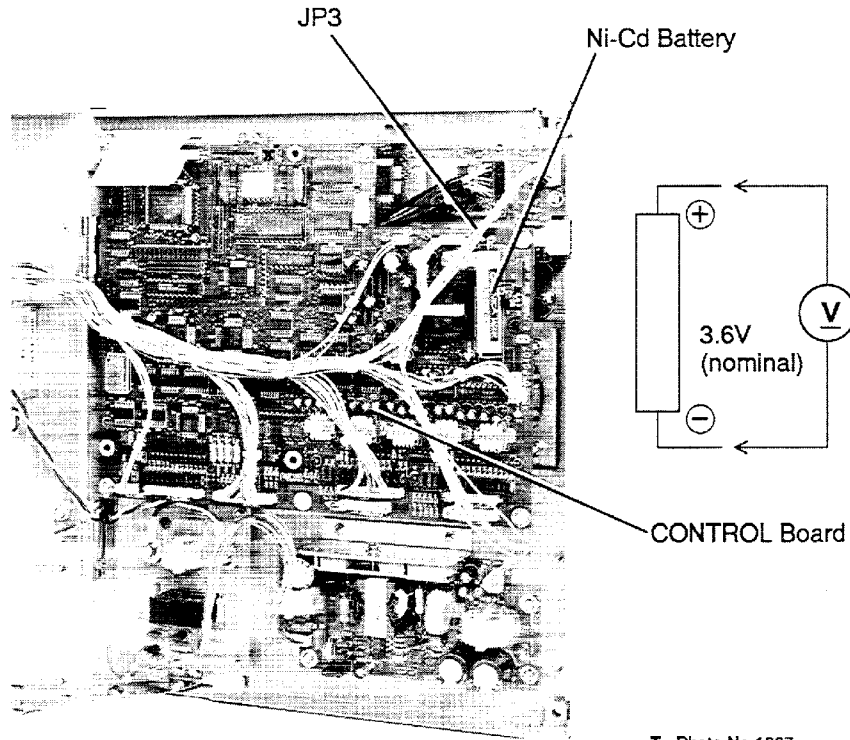

T Photo No.1227

**Behind Front Door**

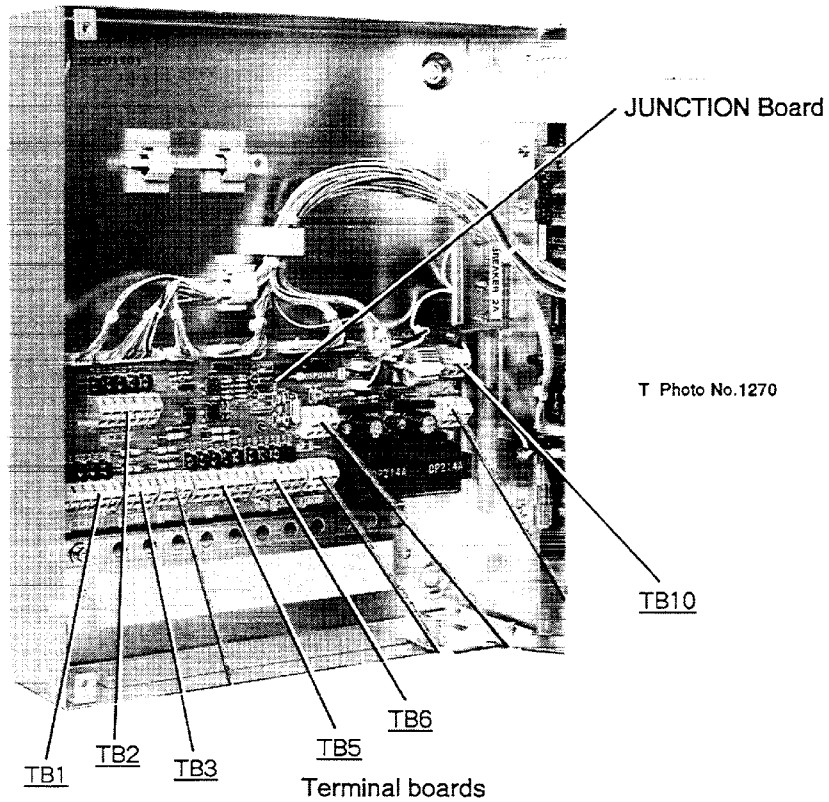

T Photo No.1270

( Power cable and interconnection cables from external equipments are terminated here. )

**Inside Cabinet Base**

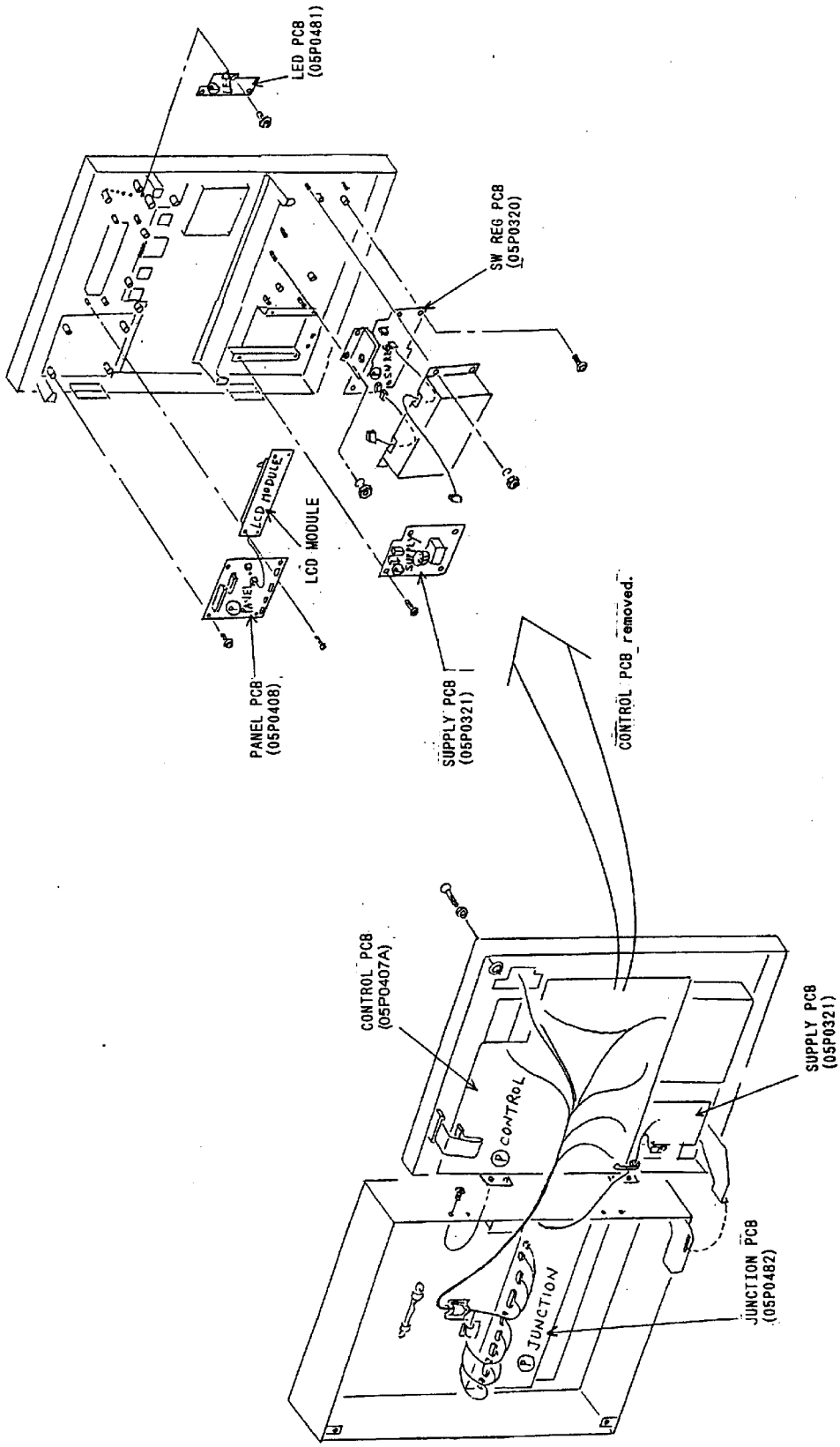

承認 APPROVED	名 TITLE	DMC-5 PCB's LOCATION
検 CHECKED		
製 DRAWN	番 DWG. NO.	

## 5.2 Self Test

This unit is equipped with two types of self tests. The first test checks for proper exchange of data between the DMC-5 and DSC to test for proper transmission of the distress message. To conduct this test, press the **TEST** switch at the default display. You should conduct this test daily to ensure proper transmission in case of distress.

Below is the procedure for conducting this test. (Note that you should also check the MF/HF transceiver for proper tuning of safety and distress frequencies, for the same reasons.)

The second type of test is a series of tests which you select through the menu to identify the cause of operating problems. If you cannot restore to normal operation do not attempt to check inside the unit. Any repair is best left to a qualified technician.

### General Self Test (Daily Self Test)

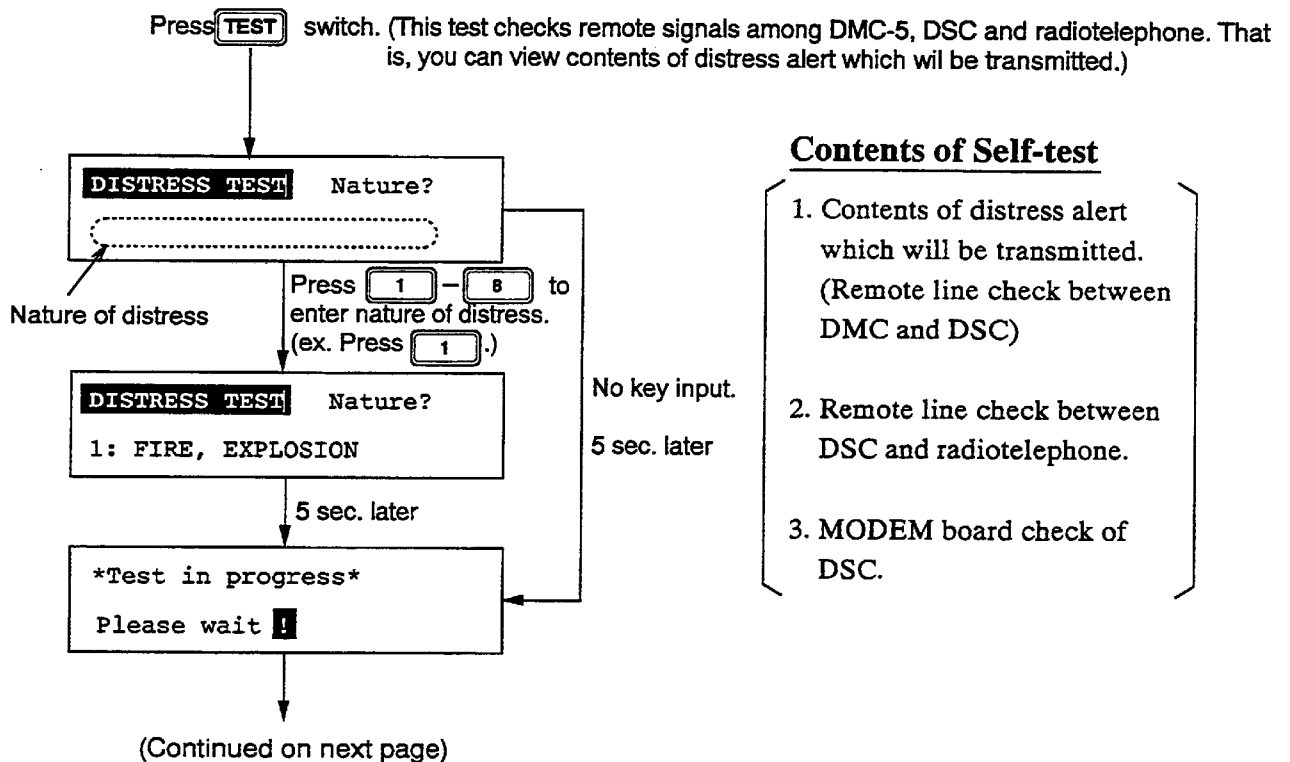

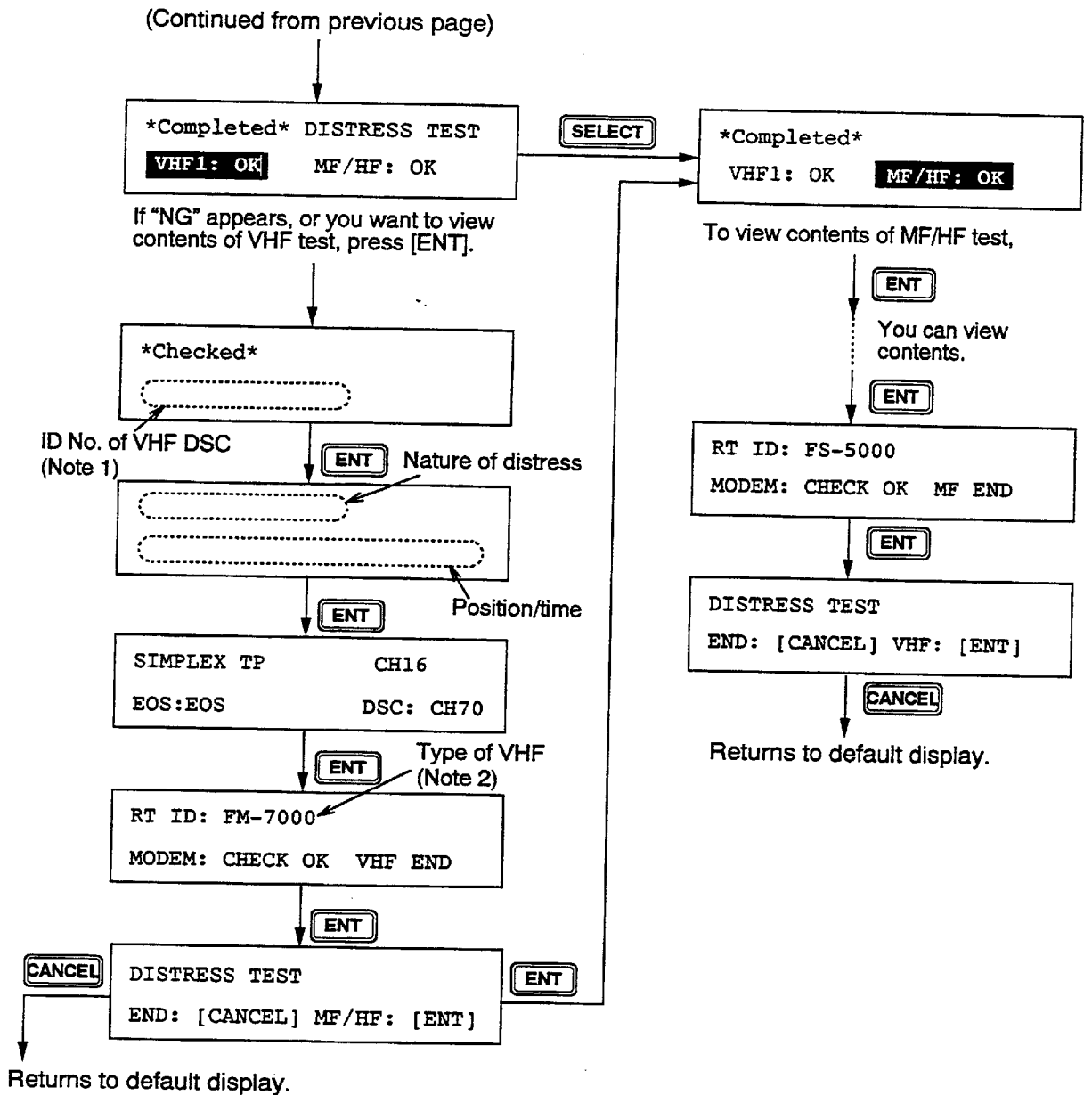

Note 1. For NG display (causes of NG):  
 1. Power of DSC may be off.  
 2. System setting Remote-A on DSC may be off.

Note 2. For NG display (causes of NG):  
 1. Power of radiotelephone may be off.  
 2. Remote line trouble between DSC and radiotelephone.

If system setting Remote-D or -E on DSC is off, "Remote off" appears.

## Individual Self Test (for maintenance)

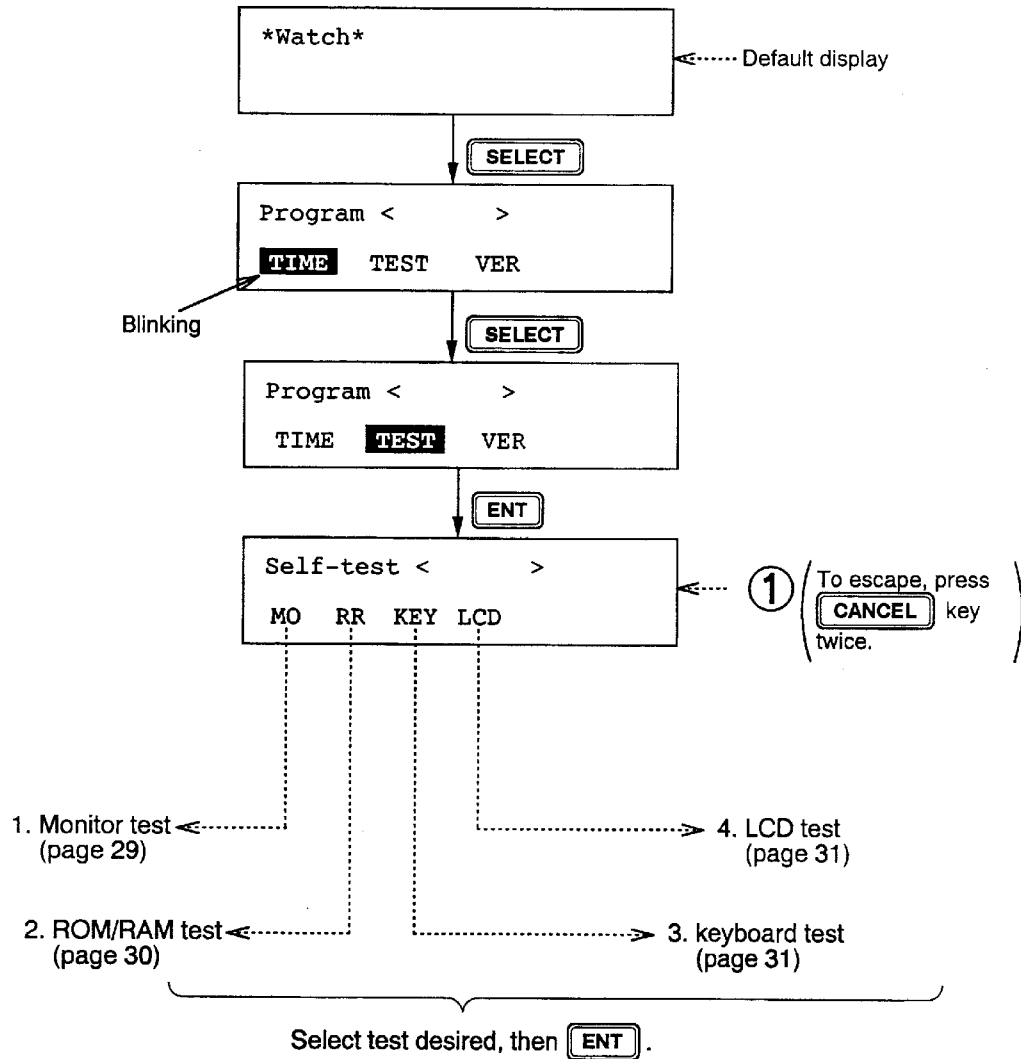

## 1. "MO" (Monitor test)

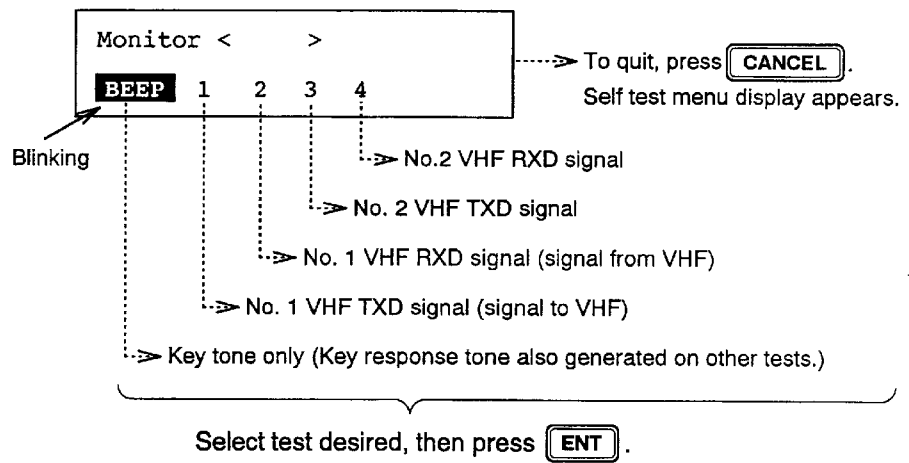

This test monitors VHF control signal tone.

## 2. "RR" (ROM/RAM test)

This check tests the ROM(U8), RAM(U9,U10) and EE – ROM(U11) on the CONTROL board.

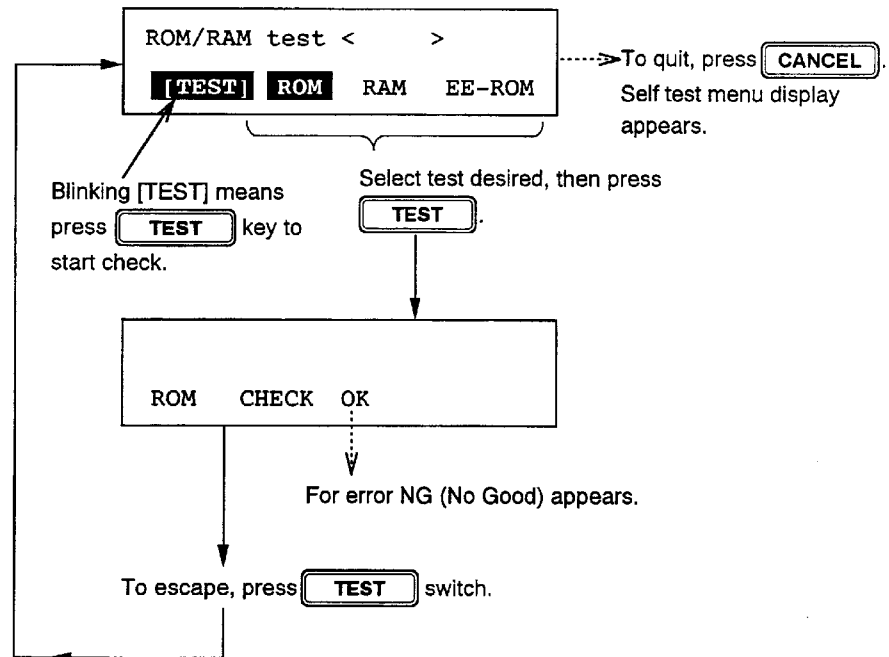

### 3. "KEY" (Keyboard test)

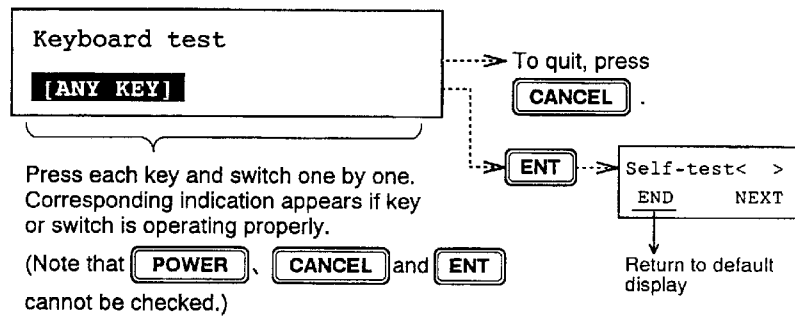

Key/switch and/or related circuit may be faulty if;

- ◆ it does not show character(s) corresponding to the key/switch pressed, or
- ◆ it will not accept a particular key/switch.

### 4. "LCD" (LCD test)

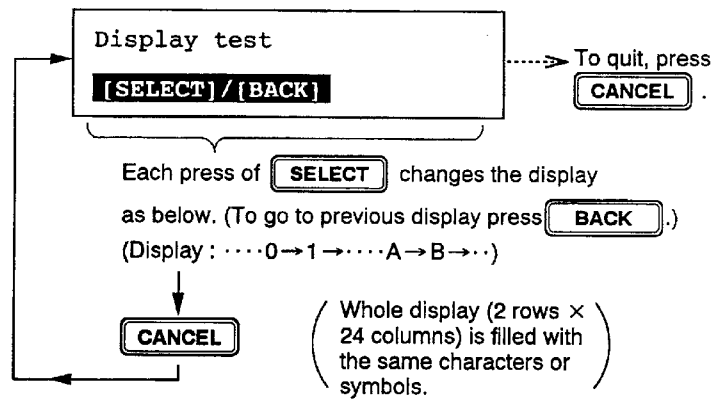

The LCD and/or its drive circuit may be faulty if;

- ◆ particular dot on the LCD is always on or off,
- ◆ particular character/symbol does not appear on the display, or
- ◆ odd (unreadable) pattern is displayed.



## 5.3 Troubleshooting (For qualified personnel)

This section shows how to check the power circuit. Before checking, be sure the red button on the breaker (2A) has not popped out. If it is out, push it in to supply power to the unit.

(If it pops out again, do not press the button any further, since it may cause more serious damage to the equipment.)

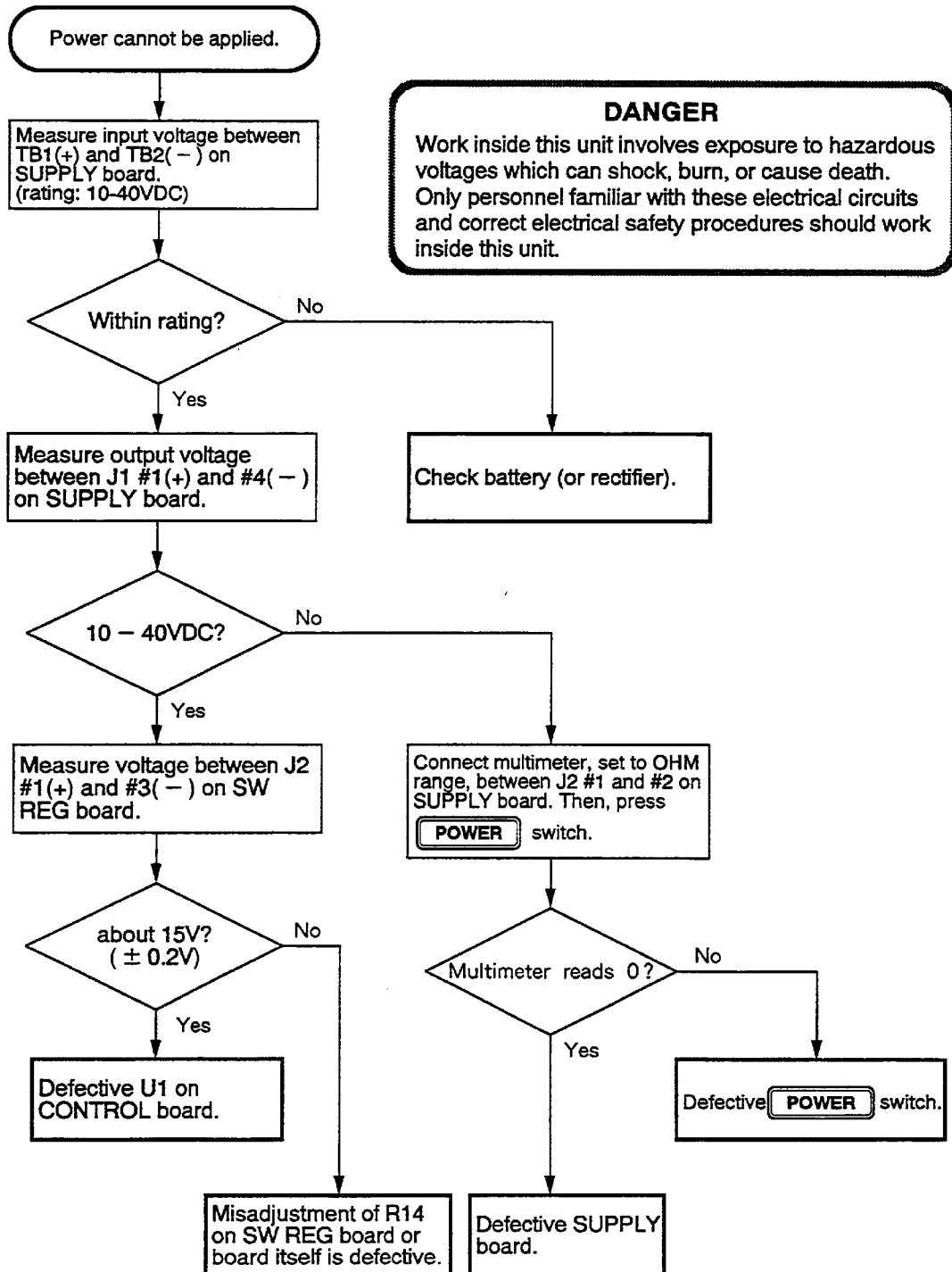

5. MAINTENANCE

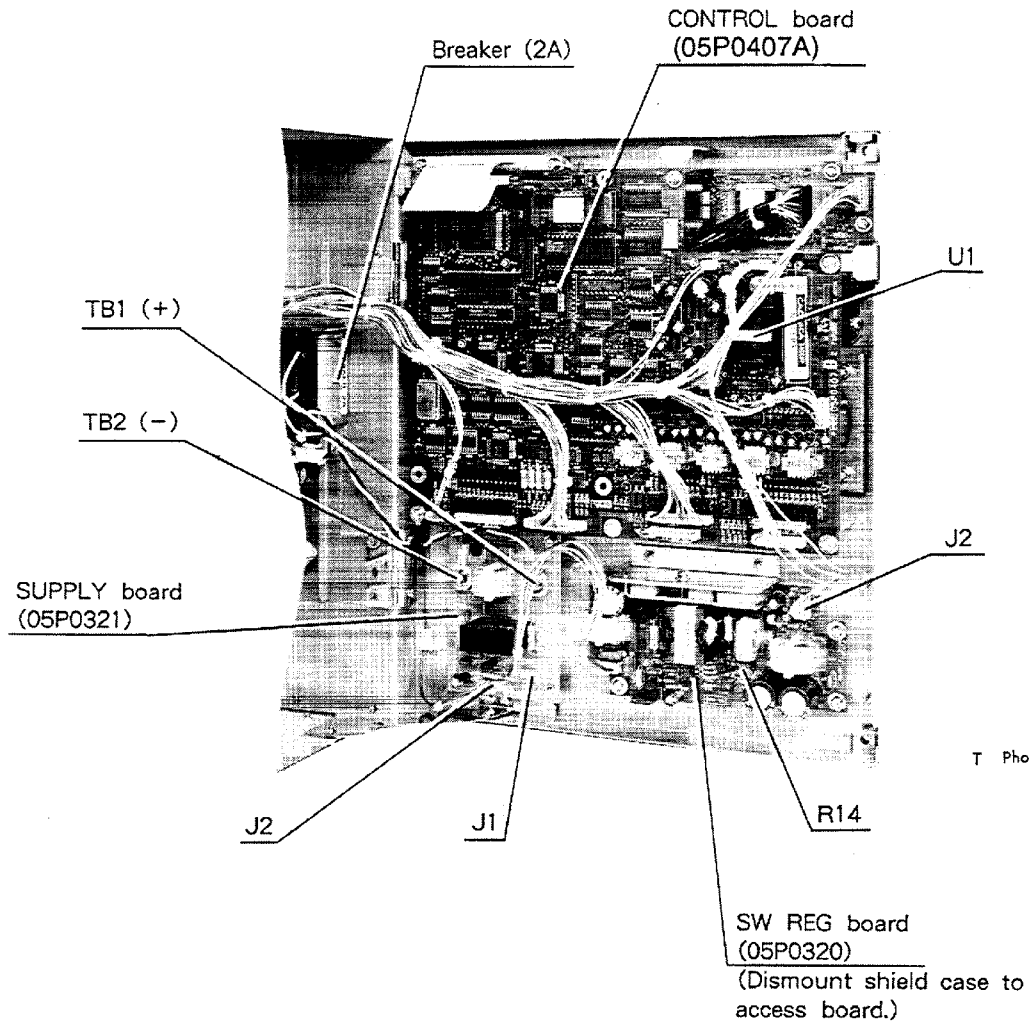

DMC-5, cabinet door opened

---

## 5.4 Displaying ROM Version Number

---

Do the following to display the ROM version number.

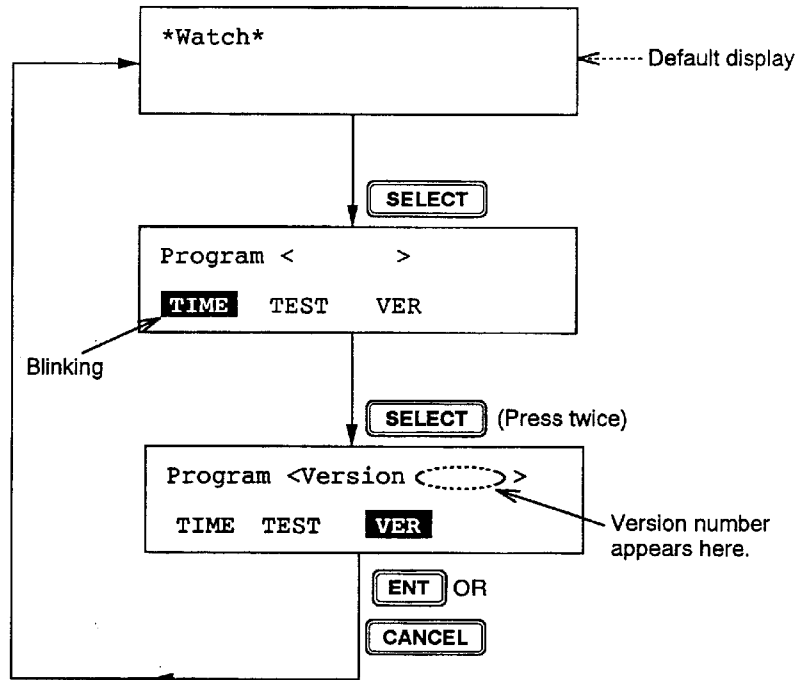

## 6. INSTALLATION

(For qualified personnel)

### 6.1 Mounting Location



The DMC-5 is normally installed on the bridge, on a bulkhead or in a panel (flush mounting kit required).

Install the unit where the **DISTRESS** switch can be readily pressed and the LCD can be easily viewed. Be sure to leave sufficient space around the unit to facilitate maintenance and checking.

Keep these and the following conditions in mind when selecting a mounting location.

- Select a location away from water splash and rain.
- Select a location where humidity and temperature are stable and moderate.
- Locate the unit away from exhaust vents.
- Select a well-ventilated location.
- Select a location where vibration and shock are minimal.

#### Compass safe distance

The performance of a magnetic gyrocompass will be affected if placed too close to the DMC-5. Separate the DMC-5 from magnetic gyrocompasses by at least the following distances.

( Standard: 1.2m )  
( Steering: 0.7m )

### 6.2 Bulkhead Mounting

Fix the unit to the mounting location with four M5 × 20 tapping screws (supplied). The mounting dimensions are shown below.

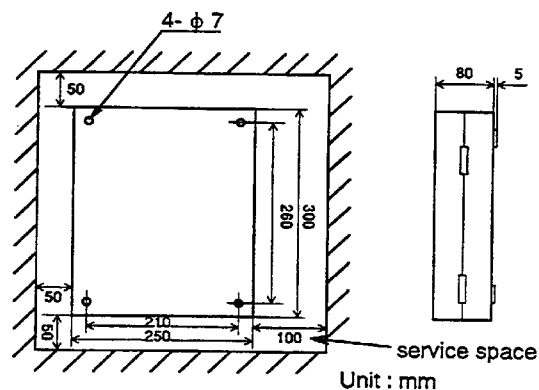

## 6.3 Flush Mounting

The DMC-5 can be flush mounted, using the optional flush mounting kit (Type : OP05-43, Code No. : 000-059-385). Be sure the mounting location is strong enough to support the weight of the unit (4 kg). If necessary, reinforce the mounting location as shown below.

### Flush mounting kit

Name	Type	Qty	Code No.	Remarks
Panel	05-056-0501-1	1	100-158-311	
Tapping Screw	M5 × 20	4	000-802-081	for fixing cosmetic panel
Panhead Screw	M5 × 10	4	000-881-486	for fixing main unit

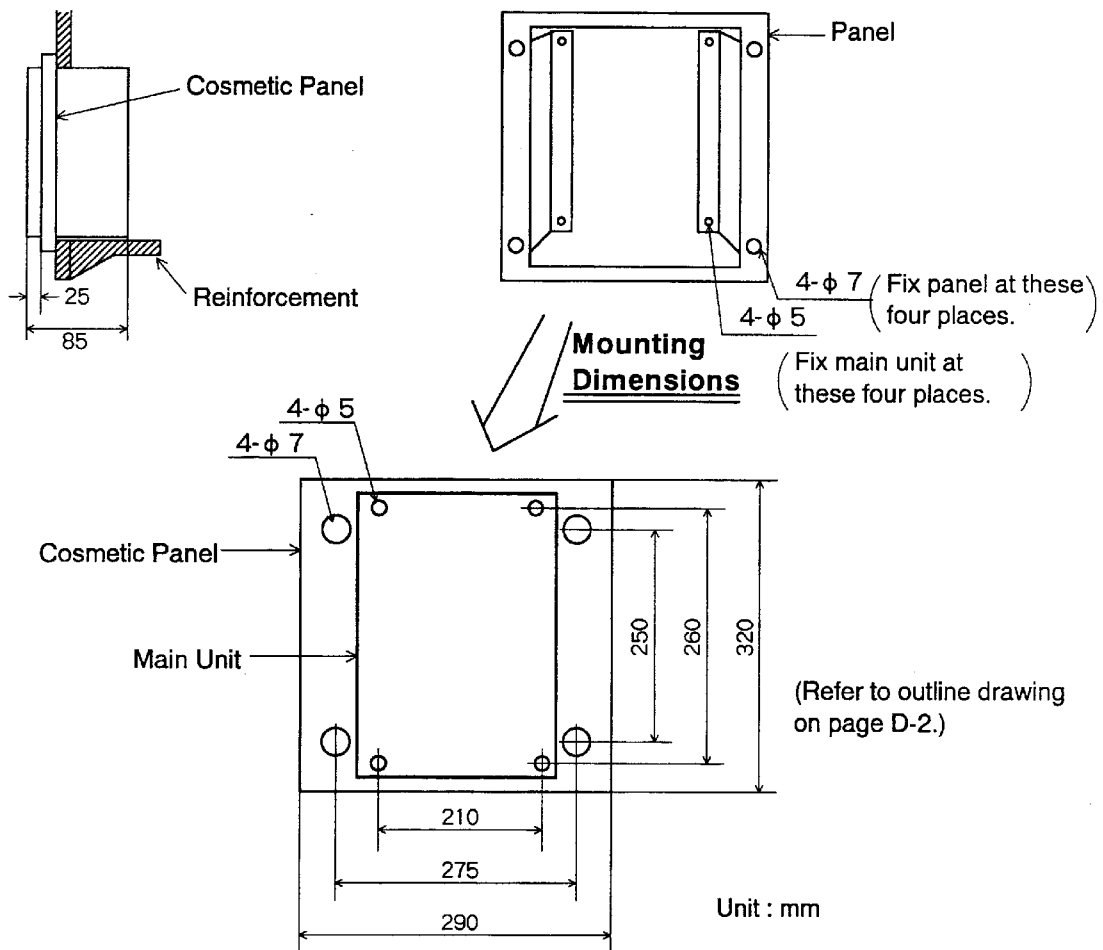

## 6.4 Connections

The power cable and interconnection cables from external equipment are terminated at the JUNCTION board inside the DMC-5.

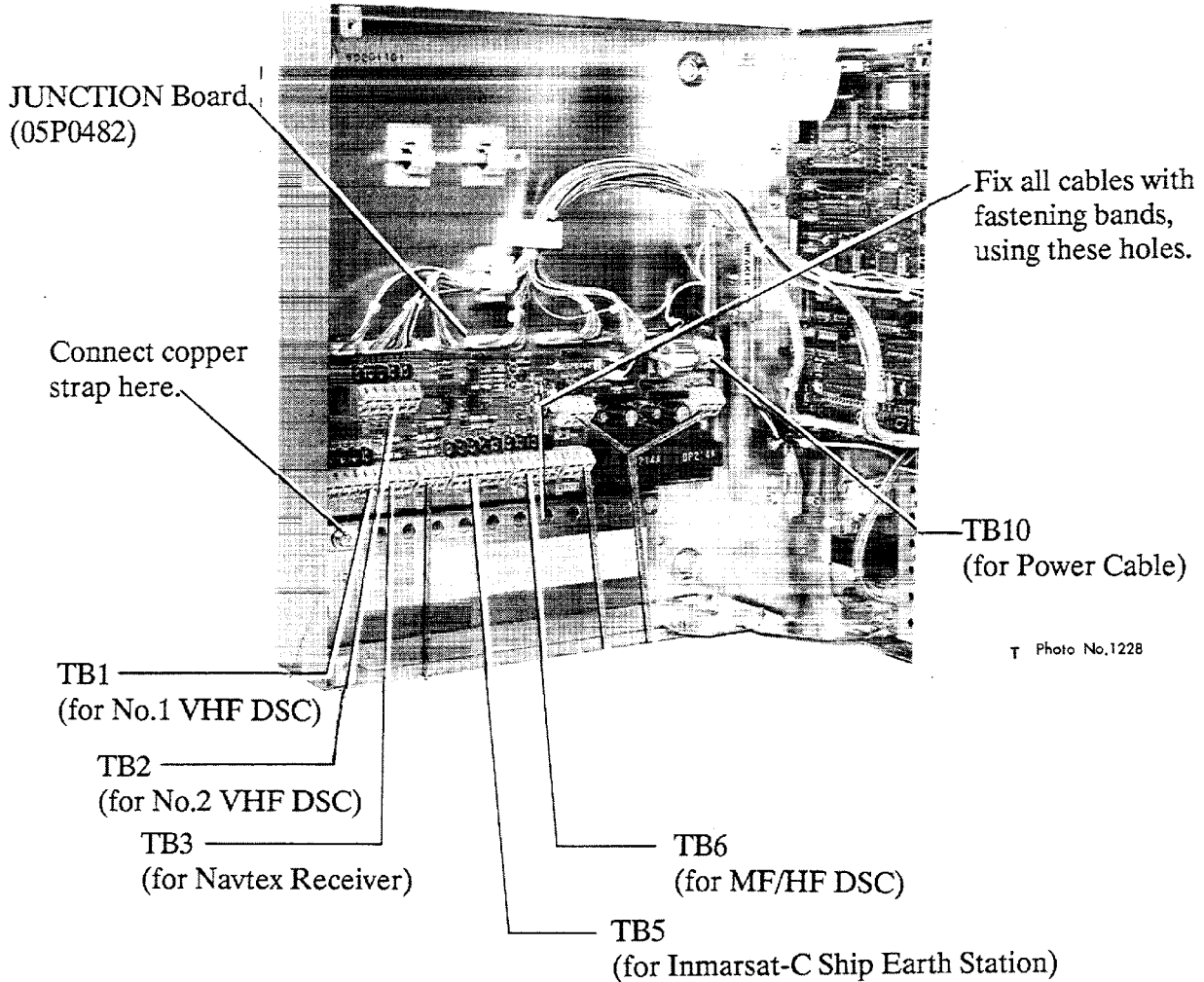

**Cable Specification:** TB5 ... Composite 10 core cable (CO-10P, optional supply). Cable available in lengths of 5m/10m/20m/30m/40m/50m.

TB10 .. DPYC-1.25 (local supply).

Other .. Composite 2 core cable (CO-2P, optional supply). Cable available in lengths of 5m/10m/15m/20m/30m.

After installing the unit, be sure to enter system settings as prescribed in the next chapter.

# 7. SYSTEM SETTINGS

## 7.1 Equipment ON/OFF

The DMC-5 needs to know what communication equipment is connected to it. Select equipment as follows.

### 1. NAVTEX Receiver

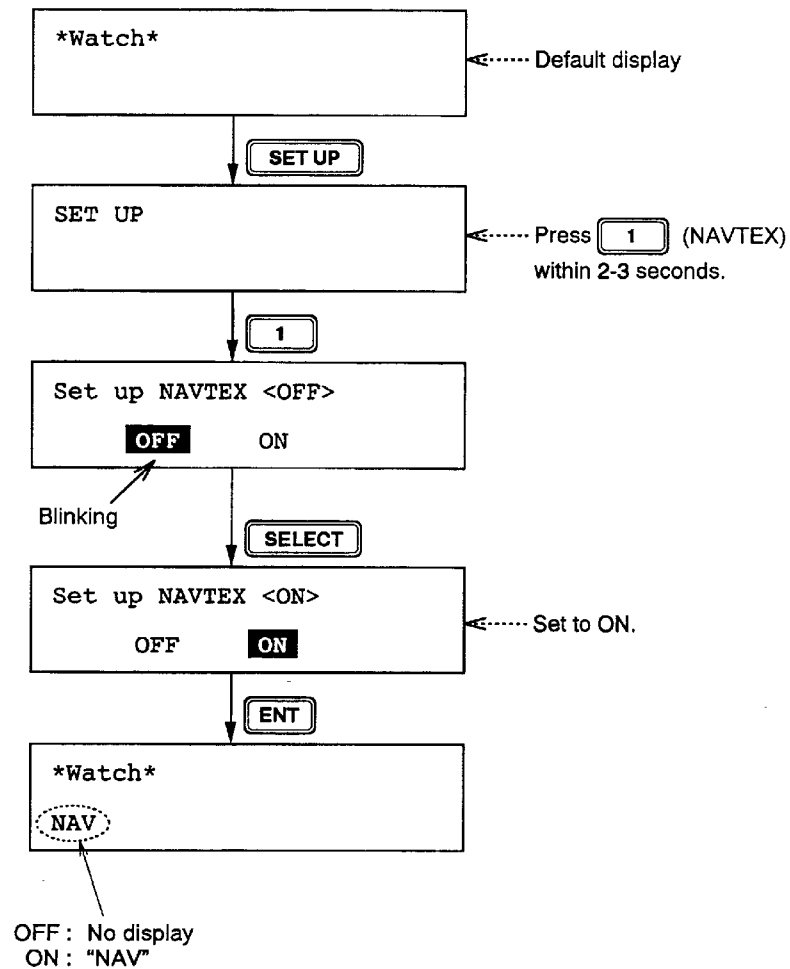

## 2. VHF DSC

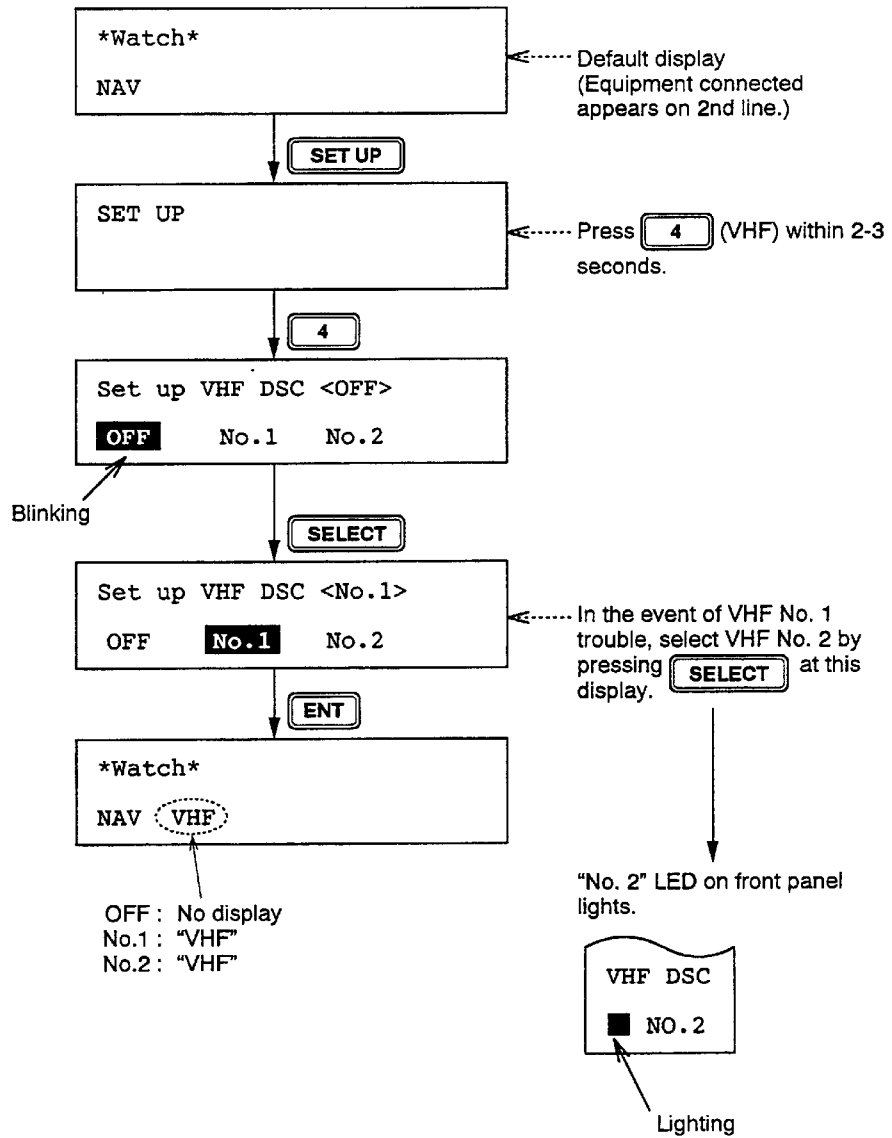



### 3. MF/HF DSC

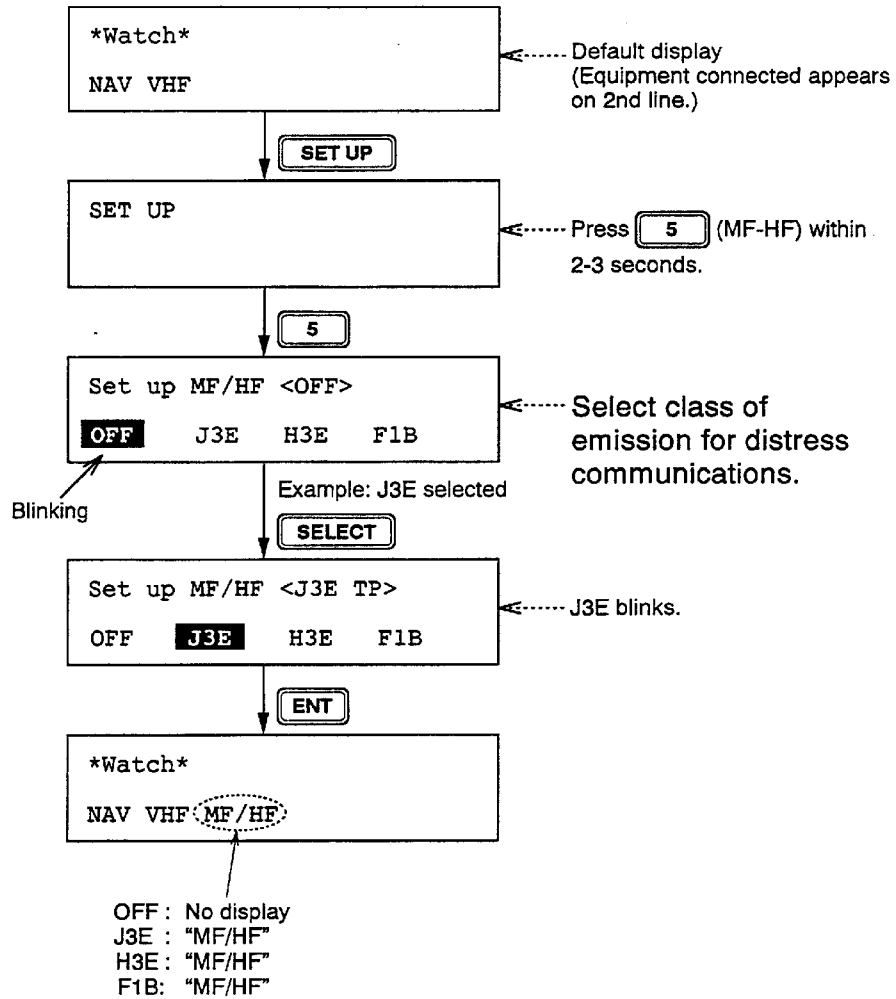

Distress call including "class of emission" selected here will be transmitted when the **DISTRESS** switch is pressed. To view the distress message which will be transmitted, conduct the self test described on page 26.

### 4. Inmarsat C SES/EGC Receiver

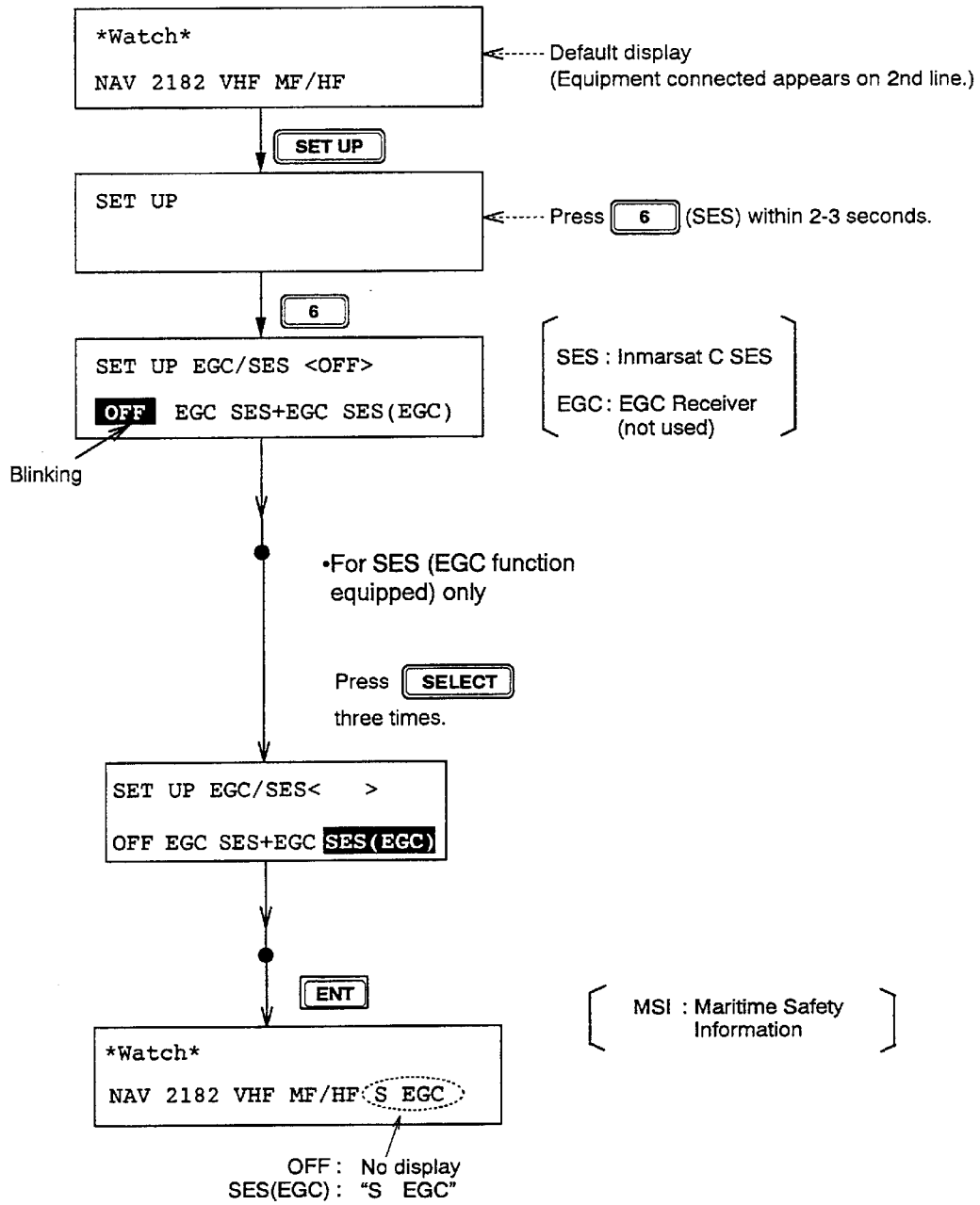

## 7.2 Alarm Tone Selection

The user may select receive alarm tone, and turn keyboard response tone on or off. In the factory setting, alarm tone no.1 is selected and keyboard response tone is turned on.

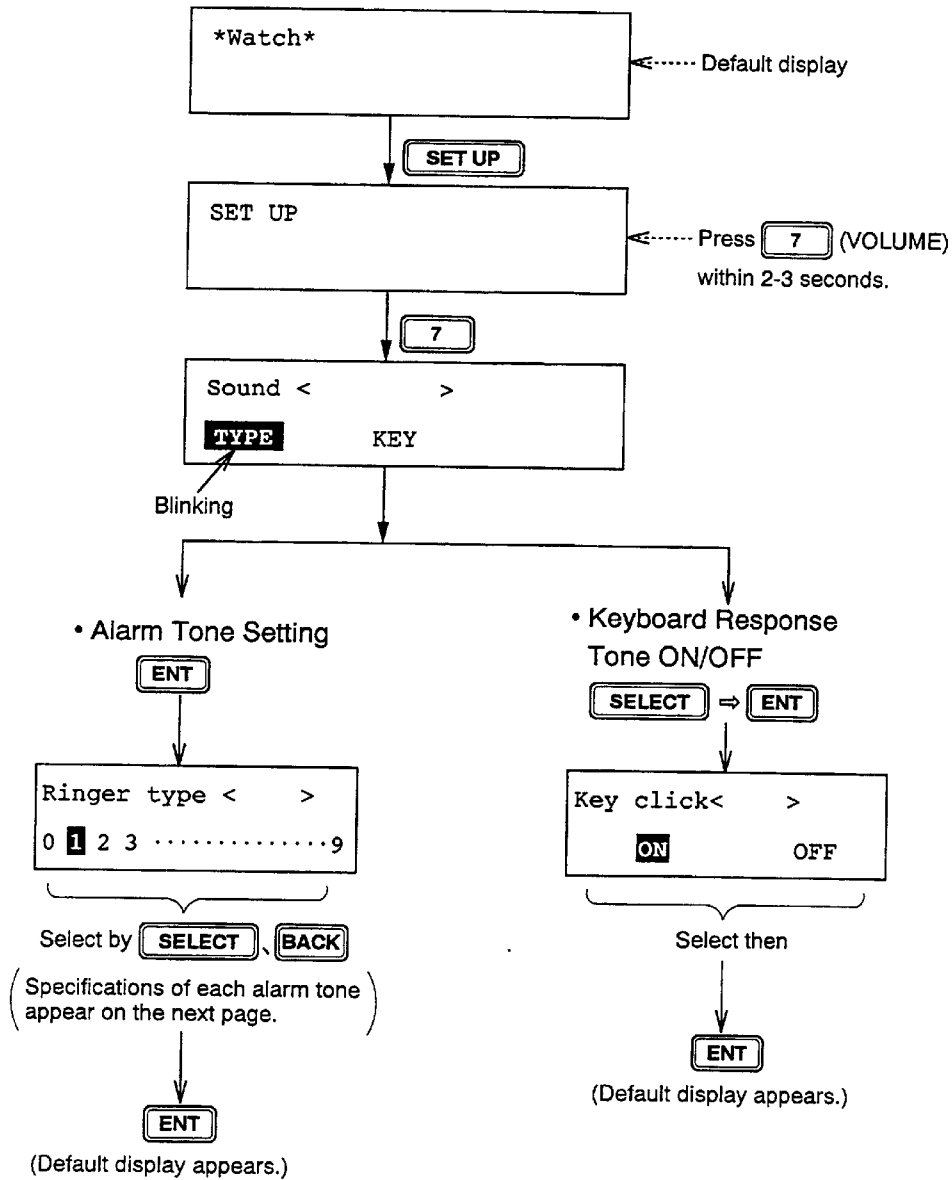

Ringer type	Specification	
	Tone (Hz)	Interval (ms)
0	2200	Continuous
1	1300 and 2200	250
2	1300 and 2200	125
3	3290	Continuous
4	1945 and 3290	250
5	1945 and 3290	125
6	1100	Continuous
7	650 and 1100	250
8	650 and 1100	125
9	2200 and 0	250

**(Note)** Key response tone frequency is 1800Hz (50ms).

The distress alarm (five seconds duration) frequencies are 2200Hz and 0Hz (interval : 125ms). These frequencies cannot be changed.

## 7.3 Date and Time

Enter date and time (UTC). Date and time entered through the DMC-5 supersedes those of DSC.

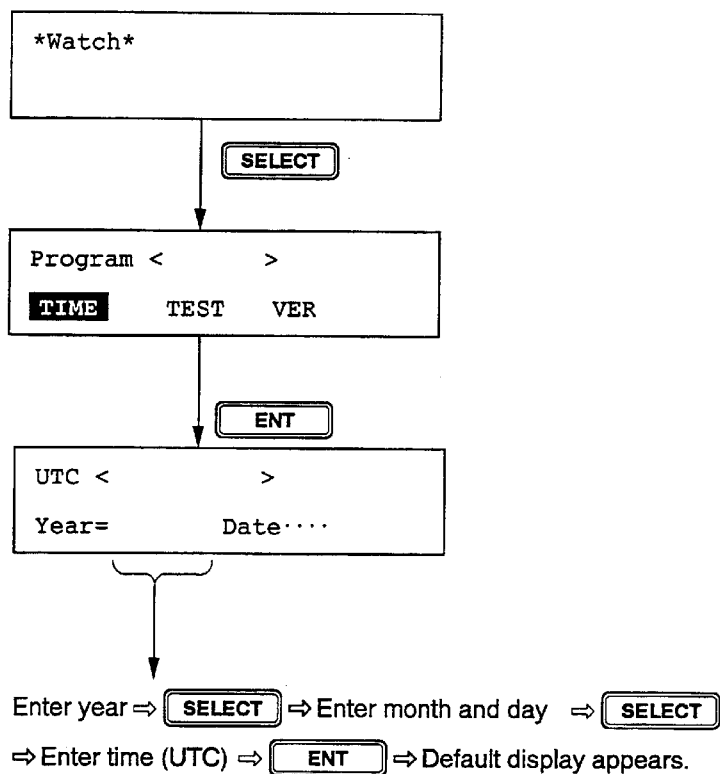

**(Example)** Enter August 1, 1997, 12:03.

{ 1997 => [SELECT] => 801 => [SELECT] => 1203 => [ENT] }

## 8. MANUAL INPUT OF SHIP'S POSITION

If own ship's position data from navigation device is not input to the DMC-5 via the DSC, you can enter it manually through the DMC-5. (If navigation device is not connected, the screen should look "Manual ship's position input display" shown below.) It is very important that position data be accurate to facilitate search and rescue operations in the event of distress.

The DMC-5 normally receives ship's position data from the VHF DSC. When this path is unavailable, the DMC-5 receives the data from the MF/HF DSC. If neither pass is available, enter the ship's position data manually by following the procedure shown below. (The data prepared here will be transmitted when the **DISTRESS** switch is pressed.)

After entering the data check both the power line of equipment connected and the CIF/NMEA line between the DSC and nav. device. Once automatic input is restored, manually entered position data is cancelled.

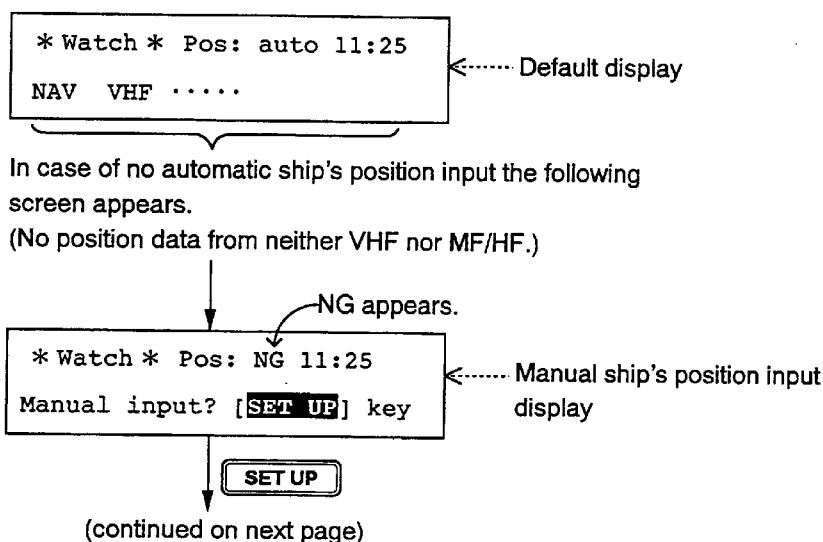

8. MANUAL INPUT OF SHIP'S POSITION

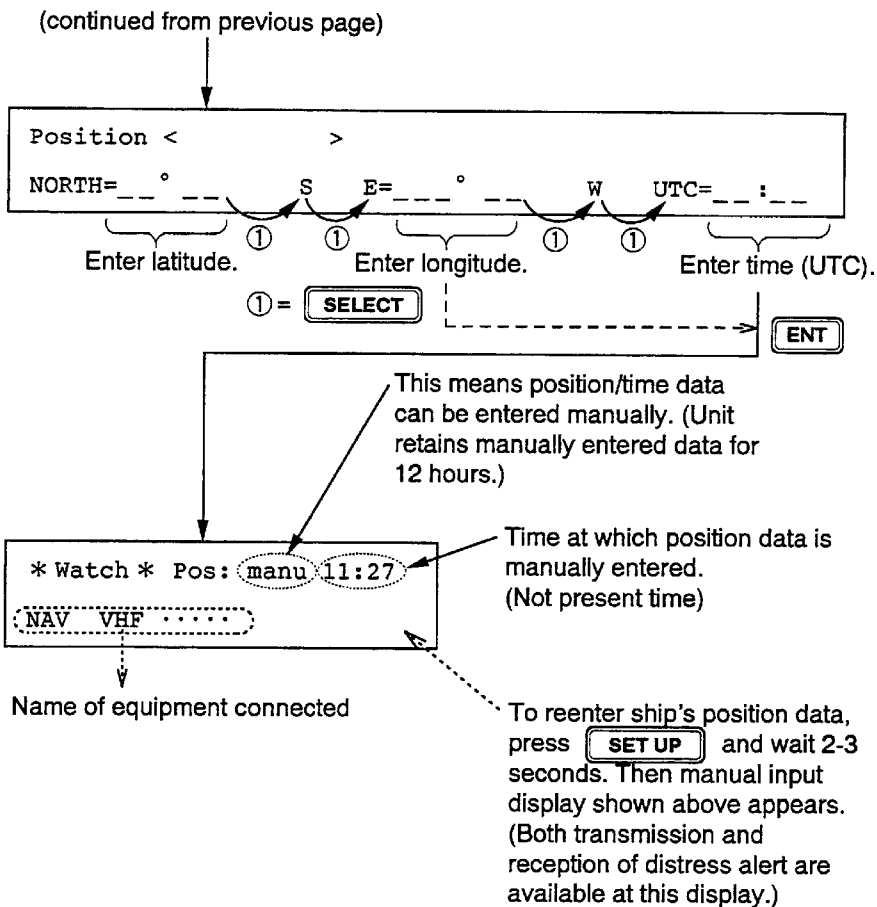

**Note:** You can confirm position and time data which will be transmitted at distress by conducting the self test described on page 26.

---

# SPECIFICATIONS OF DMC-5

## DISTRESS MESSAGE CONTROLLER

---

### 1. Functions

- |  |   |
|--|---|
| (1) Equipment Controllable                     | VHF DSC/MF DSC/HF DSC/Inmarsat class-C SES  |
| (2) Specifics of Distress Call and Message     | Nature of distress<br>Position, time (auto/manual)<br>Telecommand   |
| (3) Messages Transmittable                     | Transmit of distress call<br>Relay of distress call (MF/HF DSC)<br>Transmit of distress acknowledgement (VHF/MF DSC)  |
| (4) Protection Against Accidental Transmission | Plastic cover and red seal placed over <b>【DISTRESS】</b> key  |
| (5) Cancel of Transmission and Reset           | By <b>【CANCEL】</b> key  |
| (6) Indication of Receive Message              | Distress call<br>Distress acknowledge call (DSC only)<br>Distress relay call (DSC only)<br>Ack for distress relay   |
| (7) Alarms (Aural and Visual)                  | DSC : at transmission and reception (Volume adjustable)<br>SES : at transmission and reception (Volume adjustable)<br>EGC RCVR : at reception of SAR message<br>NAVTEX : at reception of SAR message<br>Key and LED panel are backlit |
| (8) Illumination                               |   |

### 2. Display

24 characters × 2 lines, LCD display  
LED adjustable backlight and display contrast

### 3. Key Arrangement

CCITT REC. E161



SPECIFICATIONS OF DMC-5

**4. Environmental Conditions**

- (1) Temperature – 15 °C to +55 °C
- (2) Relative Humidity 93%

**5. Power Supply and Power Consumption**

10-40 VDC, 10 W or less

**6. Coating Color**

Panel: N-3.0 Cabinet Cover: 2.5GY5/1.5

# FURUNO

AP1-3

構成表 COMPLETE SET		DMC-5 遭難警報装置 DISTRESS MESSAGE CONTROLLER			
番号 No.	名称 NAME	型式 TYPE	重量 WEIGHT (Kg)	数量 Q'TY	備考 REMARKS
1	本体 MAIN UNIT	DMC-5	4.0	1	
2	工事材料 INSTALLATION MATERIALS			1 式 SET	
3	フラッシュマウントキット FLUSH MOUNT KIT			* 1 式 SET	
4	アラームスピーカー ALARM SPEAKER	AL-5	1.4	* 1	壁掛型 BULKHEAD MOUNT
4	アラームスピーカー ALARM SPEAKER	AL-5F	0.7	* 1	埋込型 FLUSH MOUNT
* : オプション支給品。 OPTIONAL SUPPLY.					

FURUNO ELECTRIC CO., LTD.

**FURUNO**



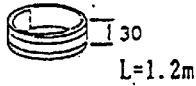

CODE No.	000-059-384	05CL-X-9401
TYPE	CP05-04900	

工事材料表 INSTALLATION MATERIALS		DMC-5 遭難警報装置 DISTRESS MESSAGE CONTROLLER			
番号 No.	名称 NAME	略図 OUTLINE	型名 / 規格 DESCRIPTIONS	数量 Q'TY	用途 / 備考 REMARKS
1	ア - ス 板 COPPER STRAP		05-003-0031-0 CODE No. 590-300-310	1	
			CODE No.		
			CODE No.		
			CODE No.		
			CODE No.		
			CODE No.		
			CODE No.		
			CODE No.		
			CODE No.		
			CODE No.		
				図番 DWG. No. C5544-M01-B	
				検図 CHECKED	

**FURUNO**

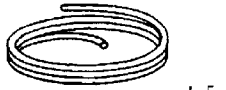
CODE NO	
TYPE	

工事材料表 INSTALLATION MATERIALS	2対ケーブル（铠装付） 2P TWISTED PAIR CABLE (WITH ARMOR)
---------------------------------	---





番号 No.	名称 NAME	略図 OUTLINE	型名 / 規格 DESCRIPTIONS	数量 Q'TY	用途 / 備考 REMARKS
1	2対ケーブル 2P TWISTED PAIR CABLE	 L=5m	CO-SPEVV-SB-C 0.2X2P *5M* 14S4231		
			CODE NO		
1	2対ケーブル 2P TWISTED PAIR CABLE	 L=10m	CO-SPEVV-SB-C 0.2X2P *10M* 14S4231		
			CODE NO		
1	2対ケーブル 2P TWISTED PAIR CABLE	 L=15m	CO-SPEVV-SB-C 0.2X2P *15M* 14S4231		
			CODE NO		
1	2対ケーブル 2P TWISTED PAIR CABLE	 L=20m	CO-SPEVV-SB-C 0.2X2P *20M* 14S4231		
			CODE NO		
1	2対ケーブル 2P TWISTED PAIR CABLE	 L=30m	CO-SPEVV-SB-C 0.2X2P *30M* 14S4231		
			CODE NO		
			CODE NO		
			CODE NO		
			CODE NO		
			CODE NO		

オプションケーブル  
 OPTION CABLE  
 数量を記入して下さい。  
 PUT QUANTITY REQUIRED.

図番 (1/1)  
 DWG. NO. C0014-M01-C

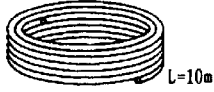
**FURUNO**

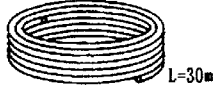
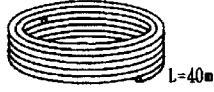
CODE NO.	
TYPE	

工事材料表 INSTALLATION MATERIALS		10対ケーブル ( 鍍装付 ) 10P TWISTED PAIR CABLE (WITH ARMOR)			
番号 No.	名称 NAME	略 図 OUTLINE	型名 / 規格 DESCRIPTIONS	数量 Q'TY	用途 / 備考 REMARKS
1	10対ケーブル 10P TWISTED PAIR CABLE	 L=5m	13S4012-0 *5M* (CO-SPEVV-SB-C 0.2X10P) CODE NO. 000-560-421		
1	10対ケーブル 10P TWISTED PAIR CABLE	 L=10m	13S4012-0 *10M* (CO-SPEVV-SB-C 0.2X10P) CODE NO. 000-560-422		
1	10対ケーブル 10P TWISTED PAIR CABLE	 L=20m	13S4012-0 *20M* (CO-SPEVV-SB-C 0.2X10P) CODE NO. 000-560-423		
1	10対ケーブル 10P TWISTED PAIR CABLE	 L=30m	13S4012-0 *30M* (CO-SPEVV-SB-C 0.2X10P) CODE NO. 000-560-424		
1	10対ケーブル 10P TWISTED PAIR CABLE	 L=40m	13S4012-0 *40M* (CO-SPEVV-SB-C 0.2X10P) CODE NO. 000-560-425		
1	10対ケーブル 10P TWISTED PAIR CABLE	 L=50m	13S4012-0 *50M* (CO-SPEVV-SB-C 0.2X10P) CODE NO. 000-560-426		
			CODE NO.		
			CODE NO.		
			CODE NO.		
			CODE NO.		
オフショーンケーブル OPTION CABLE 数量を記入して下さい。 PUT QUANTITY REQUIRED.					図 番 (1/1) DWG. NO. C0014-M04-B

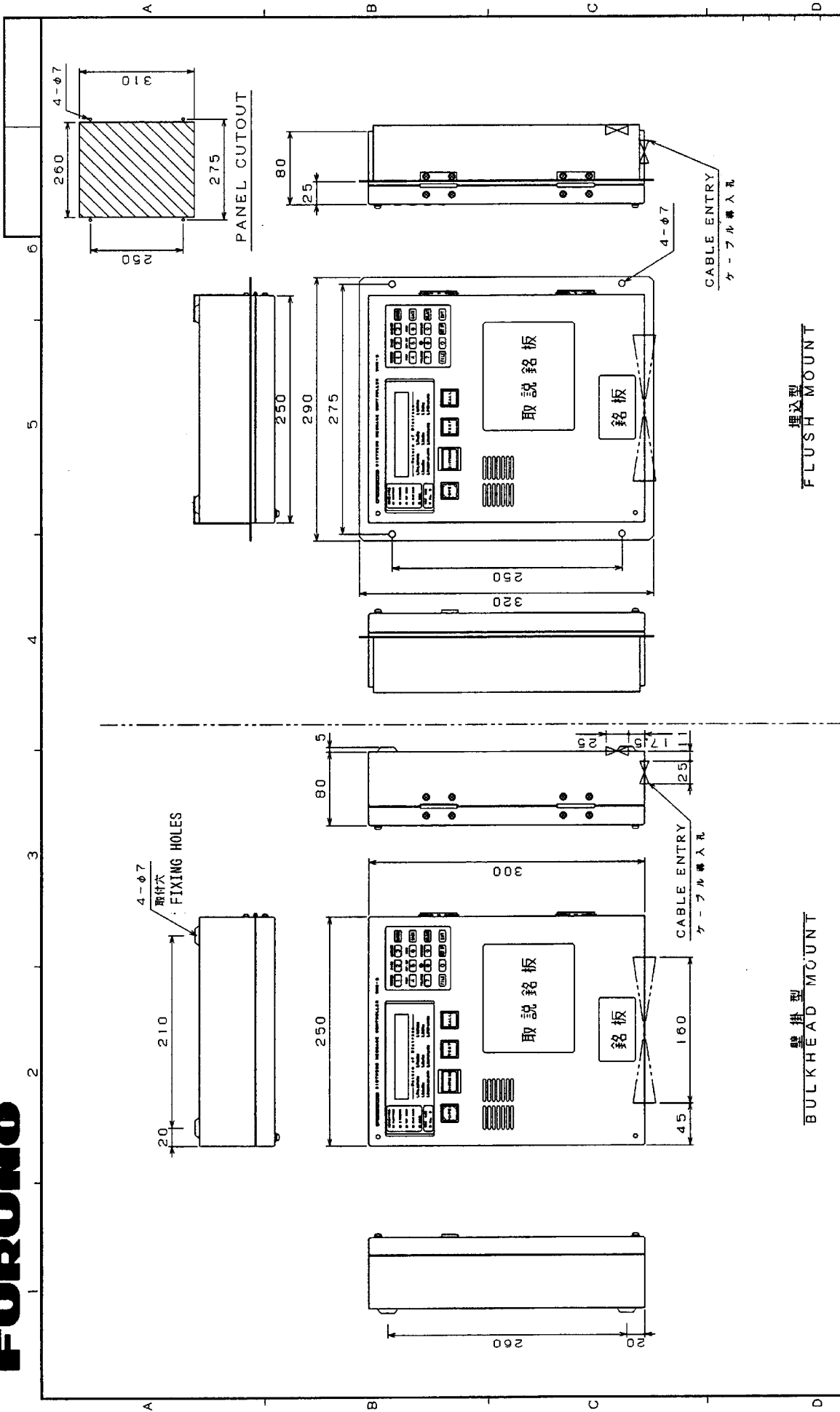

壁掛型  
BULKHEAD MOUNT

埋込型  
FLUSH MOUNT

承認 APPROVED	品名 ITEM	材料 MATERIAL	数量 QTY	図番 DWG.NO.	備考 REMARKS
検閲 CHECKED	品名 NAME	通難報装置			
製図 DRAWN	三视图 THIRD ANGLE PROJECTION	D.M.C-5 DISTRESS MESSAGE CONTROLLER			
	比例尺 SCALE	4.0 kg			
	重量 WEIGHT	C5544-G02-C			
	日期 DATE	JUN-20-91			
	姓名 NAME	H.HIDAKA			
	姓名 NAME	July 2-91			
	姓名 NAME	M. IKEDA			
	姓名 NAME	T. UAKI			
	姓名 NAME	SOL-2-91			

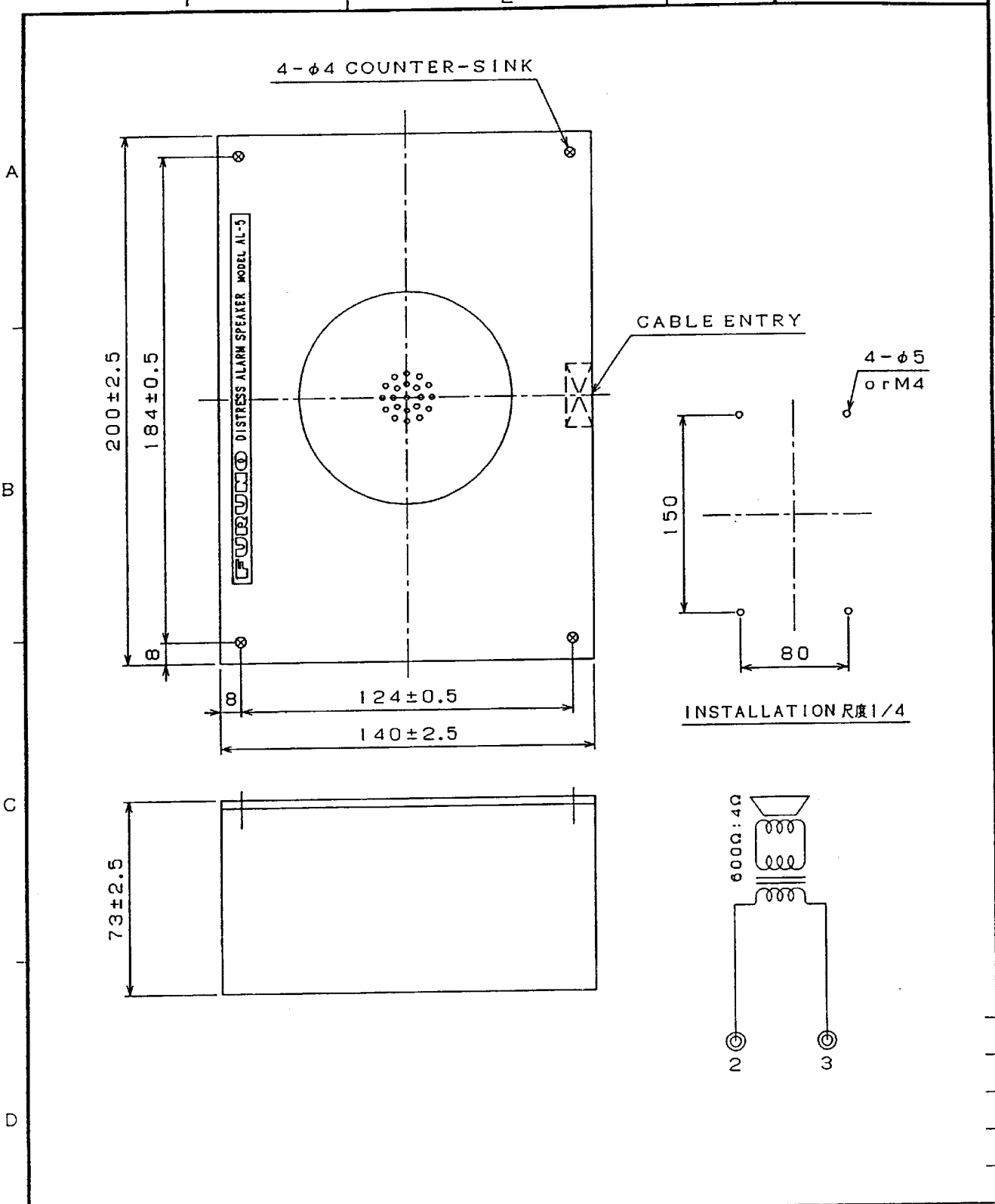

DMC-5		品番 ITEM	品名 NAME		材質 MATERIAL	数量 Q'TY	図番 DWG.NO.	摘要 REMARKS
承認 APPROVED	DEC. 25. '91 T. IJAKAWA	三角法 THIRD ANGLE PROJECTION			名称 TITLE	アラームスピーカ (壁掛型) AL-5 ALARM SPEAKER (BULKHEAD MOUNT)		
検図 CHECKED	Dec. 25. '91 M. IKEDA	尺度 SCALE	1 / 2					
製図 DRAWN	Dec. 25. '91 C. TANAKA	重量 WEIGHT	1.4 kg		図番 DWG.NO.	C5016-G04-A JN		

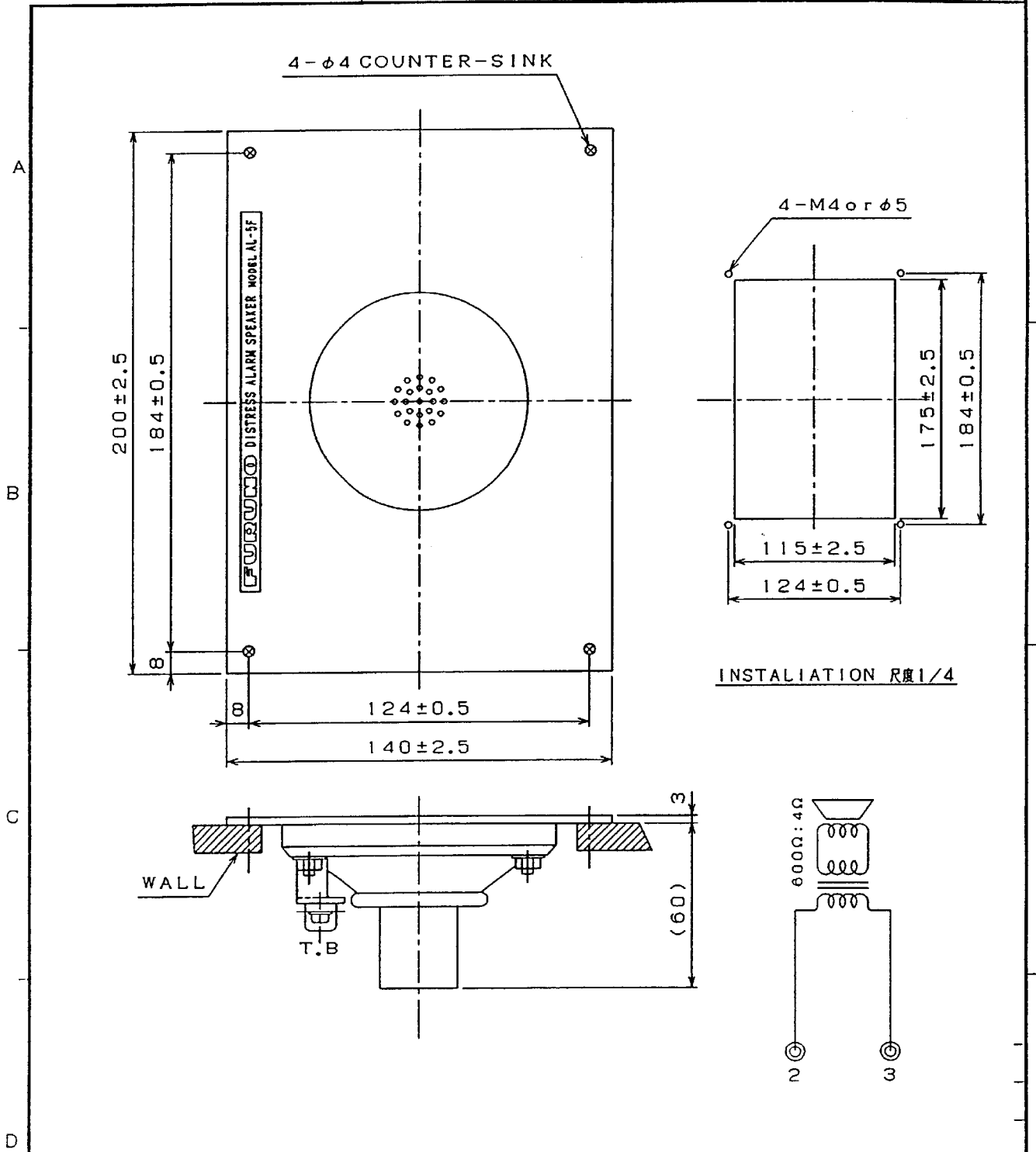

INSTALLATION 尺度 1/4

DMC-5		品番 ITEM	品名 NAME	材質 MATERIAL	数量 Q'TY	図番 DWG.NO.	摘要 REMARKS
承認 APPROVED	DEC. 25 '91 TANAKA	三角法 THIRD ANGLE PROJECTION		名称 TITLE アラームスピーカ (埋込型) AL-5F ALARM SPEAKER (FLUSH MOUNT)			
検査 CHECKED	Dec. 25 '91 M. IKEDA	尺 SCALE	度 1 / 2				
製 DRAWN	Dec. 25 '91 C. TANAKA	重 WEIGHT	0.7 kg	図番 DWG.NO.	C5016-G05-A		



6

5

4

3

2

1

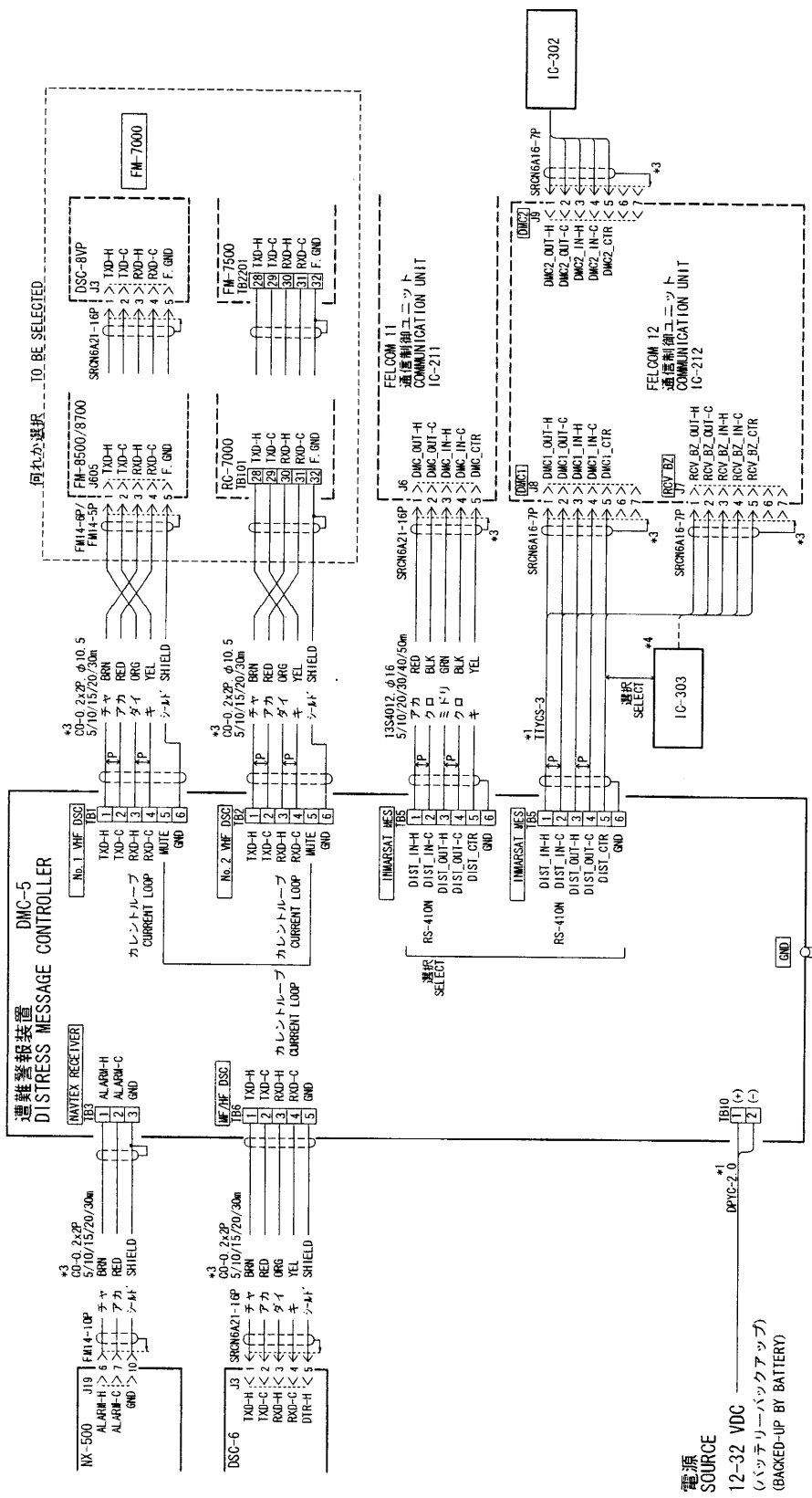

注記

- \* 1) 造船所手配。
- \* 2) FELCOM 11 (EGG機能内蔵)接続時は不要。
- \* 3) コネクターランプ経由で接地。
- \* 4) DMC-5上で遭難警報発呼と着信指示の両機能を有効にするには、DMC-5とIC-212 (J7, J8) を並列接続してください。ただし、IC-303を接続する場合は、DMC-5 (TB-5) とIC-212 (J7) の接続は絶対に行いません。誤発射の原因になります。

NOTE

- \* 1. SHIPYARD SUPPLY
- \* 2. EGG FUNCTION IS INCLUDED IN FELCOM 11.
- \* 3. GROUND CABLE THRU CONNECTOR CLAMP
- \* 4. DMC-5 (TB5) MUST BE CONNECTED TO IC-212 (J8 (DMC1)) AND J7 (RCV BZ) BOTH TO TRANSMIT "DISTRESS ALERT" AND TO INDICATE "RECEIVED CALL". NEVER CONNECT DMC-5 (TB5) TO IC-212 (J7) IN PARALLEL WITH IC-303. OTHERWISE FALSE DISTRESS ALERT TRANSMISSION WILL RESULT.

CO-0 2x2P CO-SPEVU-SB-C 0 2x2P φ10.5  
CO-0 2x5P CO-SPEVU-SB-C 0 2x5P φ13.5

DRAWN Dec 28 '00 CHECKED Y. Yamasaki APPROVED Y. Kawai SCALE 1:1 DMC No. C5544-C01-G	TITLE DMC-5 名称 遭難警報装置 相互接続図 NAME DISTRESS MESSAGE CONTROLLER INTERCONNECTION DIAGRAM
---	---

6

5

4

3

2

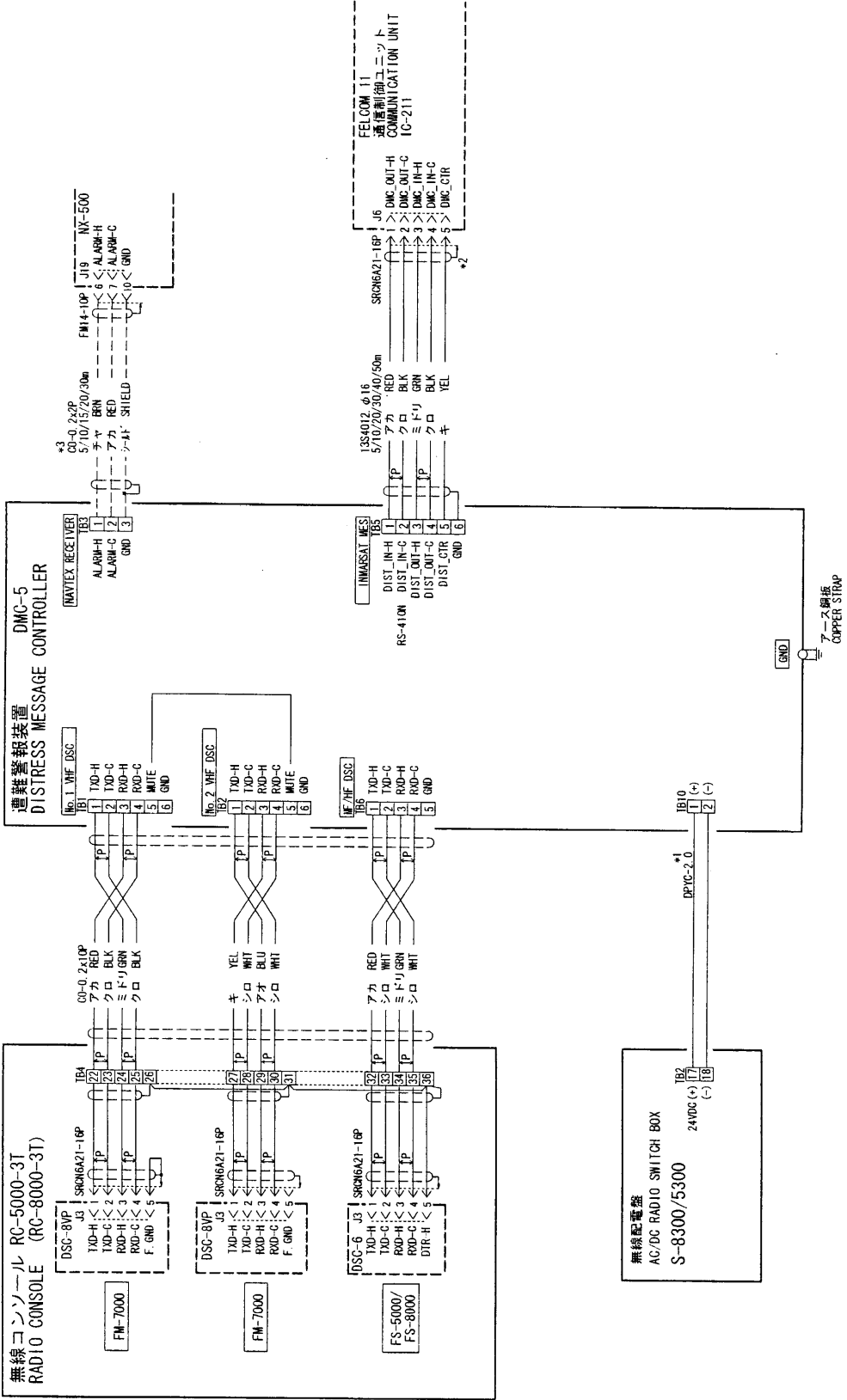

DRAWN Dec 28, 00	I. YAMASAKI	TITLE	DMC-5
CHECKED		名称	遭難警報装置
APPROVED		相互結線図	
SCALE	RC5000-3T RC5000-3T	NAME	DISTRESS MESSAGE CONTROLLER
DMC No.	C5544-002-E		INTERCONNECTION DIAGRAM

FURUNO ELECTRIC CO., LTD.

注記 \* 1) 造船所手配。  
\* 2) コネクタクランプ経由で接地。

NOTE \*1. SHIPYARD SUPPLY  
\*2. GROUND CABLE THRU CONNECTOR CLAMP.

CO-0 2x2P: CO-SPEWV-SB-C 0. 2x2P. φ10.5  
CO-0 2x5P: CO-SPEWV-SB-C 0. 2x5P. φ13.5  
CO 0 2x10P: CO-SPEWV-SB-C 0. 2x10P. φ16.5

A

B

C

D

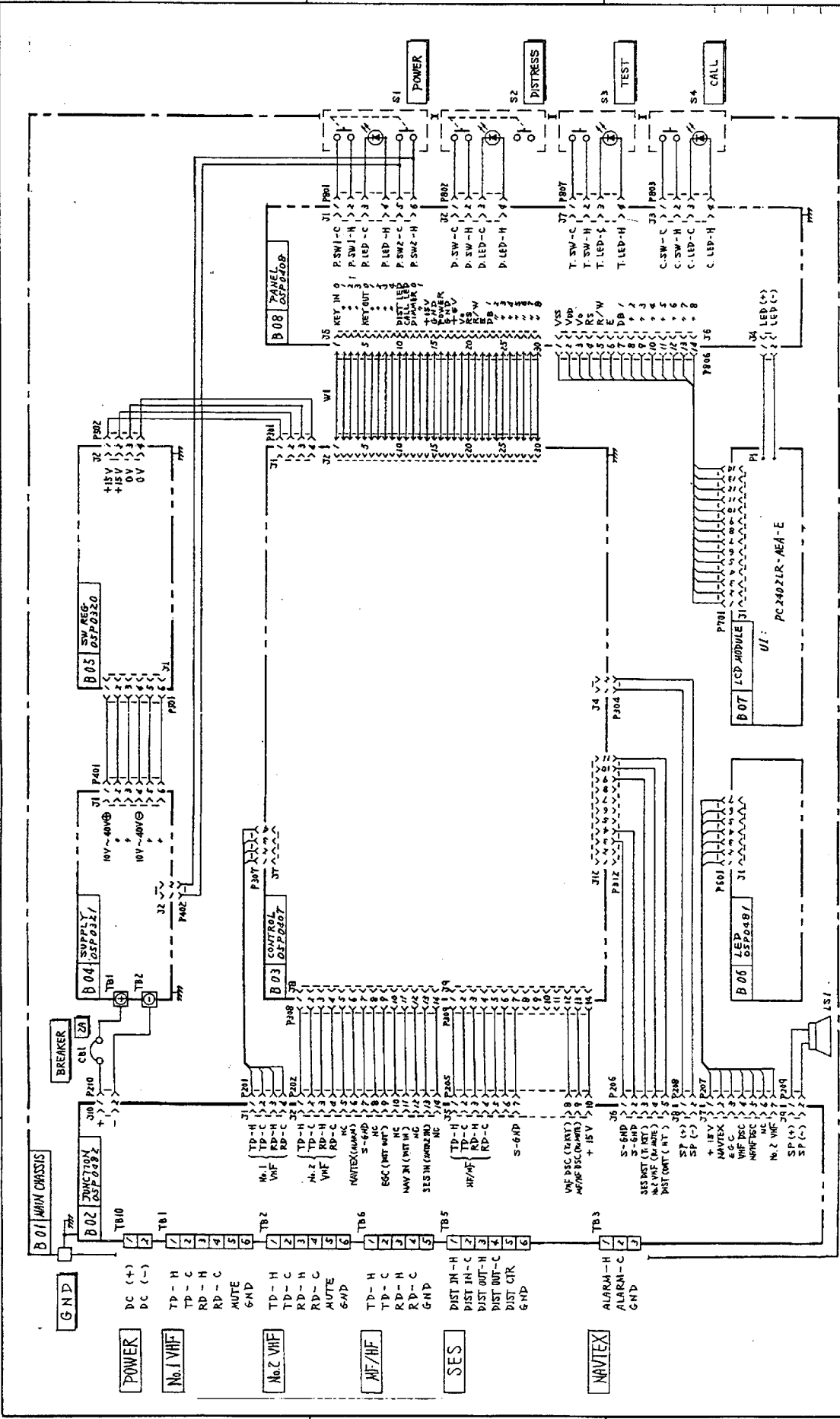

TYPE	DMC-5
名称	distress 装置 (総合)
図号	回路図
NAME	DISTRESS MESSAGE CONTROLLER
SCHEMATIC DIAGRAM	
BLOCK NO.	05-001-3407-4
APPLICABLE TO:	(MODEL)
DATE	05-001-3407-C
SCALE	1/1
DRW. NO.	C5544-K03-C
DRW. DATE	1999.09.09
DRW. NAME	T. YAMASAKI
DRW. SCALE	1/1
DRW. NO.	K. KAWABUCHI
DRW. DATE	1999.09.09
DRW. NAME	K. KAWABUCHI
DRW. SCALE	1/1

**FURUNO**

B02

承認 APPROVED	設計 DESIGNED	検閲 CHECKED	製図 DRAWN
100.08.91	100.10.91	100.16.91	100.16.91
TAKAJI			
05P0482 JUNCTION BOARD			
名 称 TITLE			
05P0482 JUNCTION BOARD			
製 図 番 号 DWG. NO.			
C5544-K02-B			

DMC-5

FURUNO ELECTRIC CO., LTD.

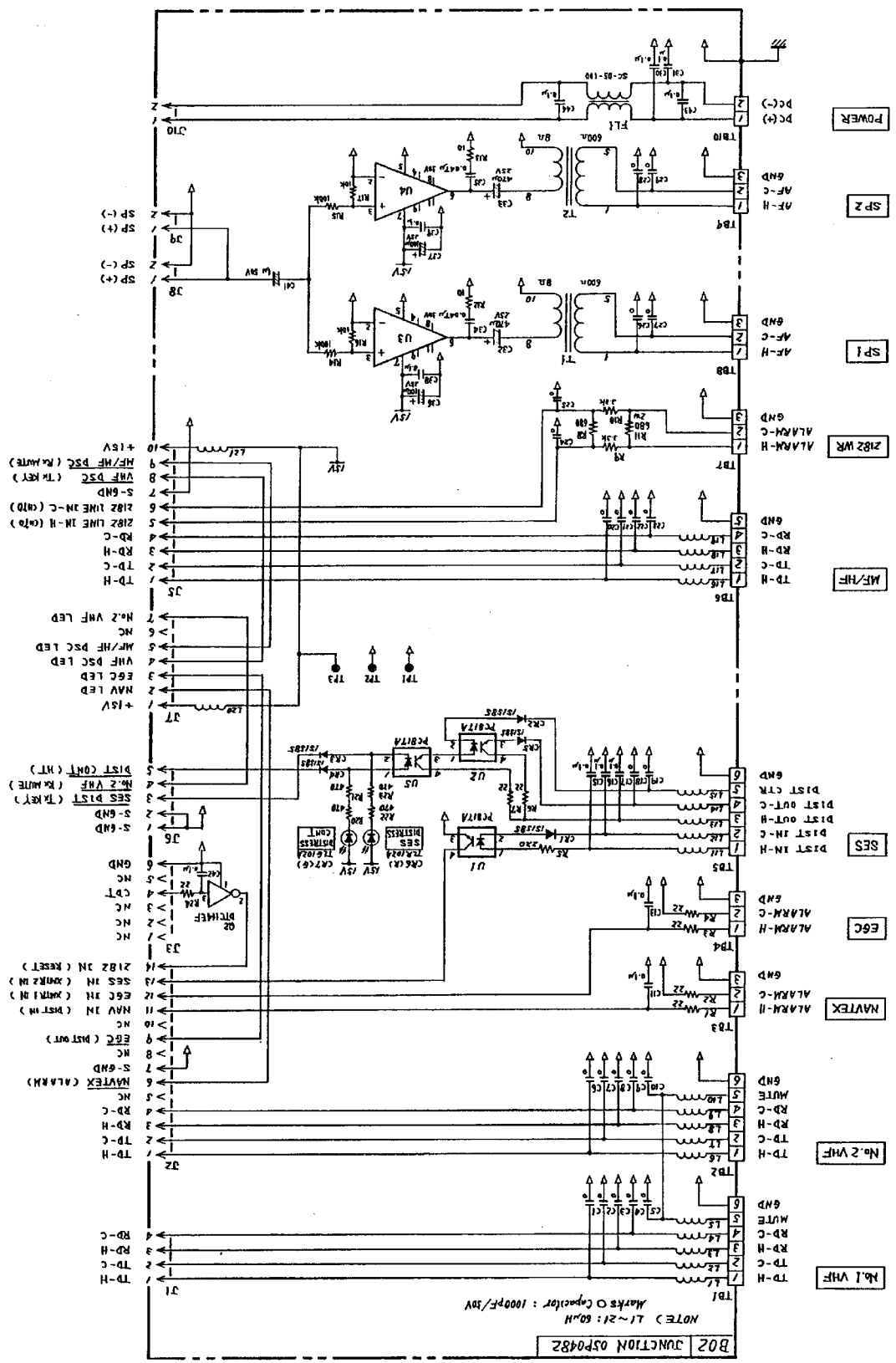

6  
5  
4  
3  
2

SP (+)  
SP (-)  
SP (+)  
SP (-)

10 +15V  
9 MF/HF PSC (RMATE)  
8 VHF PSC (TRKEY)  
7 S-GND  
6 21B2 LINE IN-C (CMTD)  
5 21B2 LINE IN-H (CMTD)  
4 RD-C  
3 RD-H  
2 TD-C  
1 TD-H

7 NAV LED  
6 MF/HF PSC LED  
5 VHF PSC LED  
4 EGC LED  
3 NAV LED  
2 +15V

5 DIST COM1 (HT)  
4 SES P1ST (TRKEY)  
3 SES P1ST (RMATE)  
2 S-GND  
1 GND

10 NAVTEX (ALARM)  
9 NAVTEX (PST IN)  
8 EGC IN (PST IN)  
7 SES IN (PST IN)  
6 21B2 IN (RESET)  
5 NC  
4 NC  
3 NC  
2 NC  
1 NC

10 TB1  
9 TB2  
8 TB3  
7 TB4  
6 TB5  
5 TB6  
4 TB7  
3 TB8  
2 TB9

POWER

SP 2

SP 1

21B2 WR

ALARM-H  
ALARM-C  
GND

MF/HF

TD-H  
TD-C  
RD-H  
RD-C  
GND

SES

EGC

NAVTEX

ALARM-H  
ALARM-C  
GND

No.2 VHF

No.1 VHF

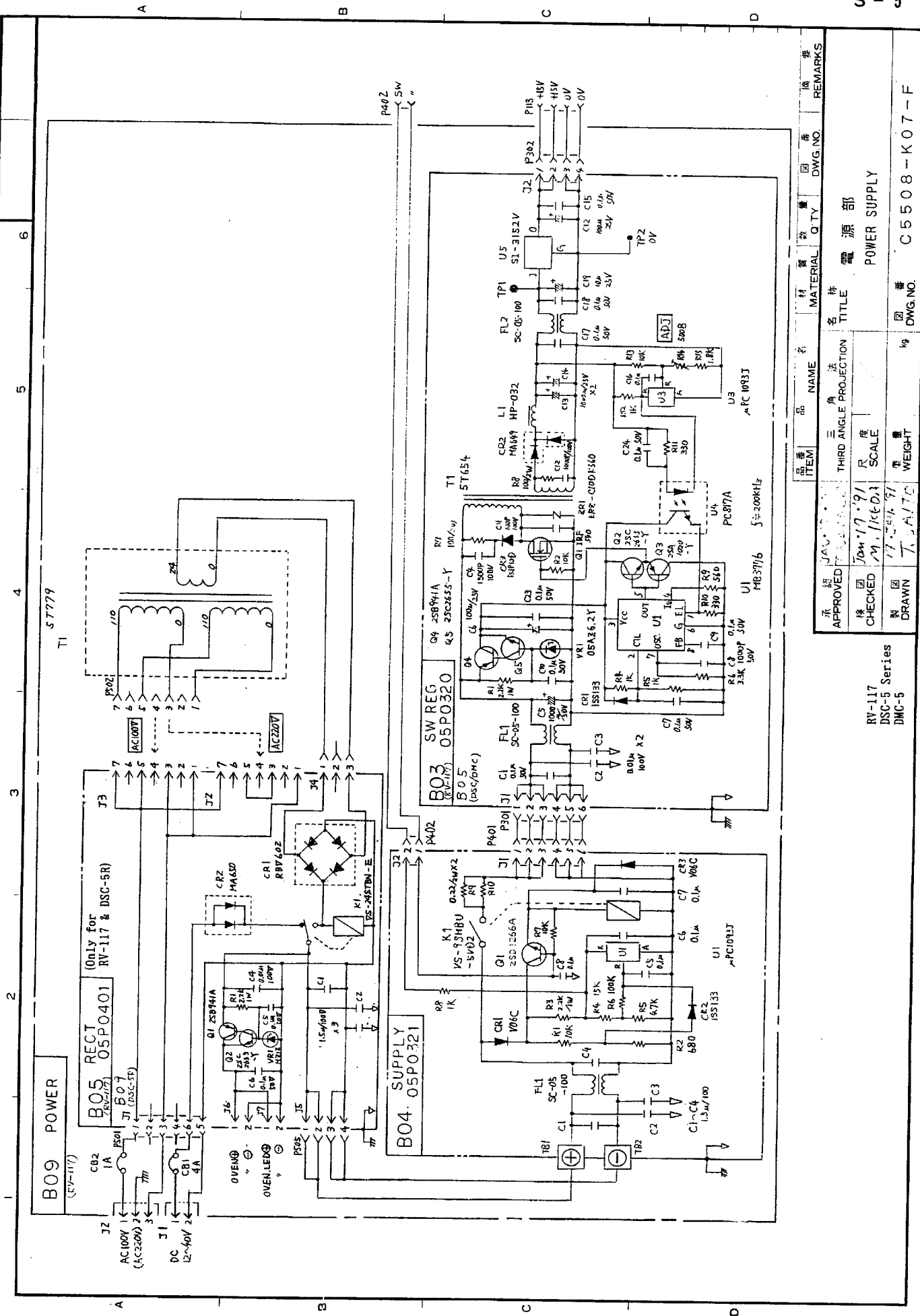

ITEM	品名	数量	材料	圖號	備註
THIRD ANGLE PROJECTION					
SCALE					
WEIGHT					
DRAWN					
CHECKED					
APPROVED					

承製	JAG	品名	電 源 部
檢閱	Tom. 19.91	圖 號	C5508-K07-F
製圖	M. K. D.	圖 號	C5508-K07-F
繪圖	T. A. T. C.	圖 號	C5508-K07-F

RV-117 Series  
DSC-5  
DMC-5

POWER SUPPLY