

FURUNO

OPERATOR'S MANUAL

NETWORK SOUNDER

Model

DFF3

IMPORTANT NOTICES

General

- This manual has been authored with simplified grammar, to meet the needs of international users.
- The operator of this equipment must read and follow the instructions in this manual. Wrong operation or maintenance can void the warranty or cause injury.
- Do not copy any part of this manual without written permission from FURUNO.
- If this manual is lost or worn, contact your dealer about replacement.
- The contents of this manual and equipment specifications can change without notice.
- The example screens (or illustrations) shown in this manual can be different from the screens you see on your display. The screens you see depend on your system configuration and equipment settings.
- Save this manual for future reference.
- Any modification of the equipment (including software) by persons not authorized by FURUNO will void the warranty.
- The following concern acts as our importer in Europe, as defined in DECISION No 768/2008/EC.
 - Name: FURUNO EUROPE B.V.
 - Address: Siriusstraat 86, 5015 BT, Tilburg, The Netherlands
- The following concern acts as our importer in UK, as defined in SI 2016/1025 as amended SI 2019/470.
 - Name: FURUNO (UK) LTD.
 - Address: West Building Penner Road Havant Hampshire PO9 1QY, U.K.
- All brand, product names, trademarks, registered trademarks, and service marks belong to their respective holders.

How to discard this product

Discard this product according to local regulations for the disposal of industrial waste. For disposal in the USA, see the homepage of the Electronics Industries Alliance (<http://www.eiae.org/>) for the correct method of disposal.

How to discard a used battery

Some FURUNO products have a battery(ies). To see if your product has a battery, see the chapter on Maintenance. If a battery is used, tape the + and - terminals of the battery before disposal to prevent fire, heat generation caused by short circuit.

In the European Union

The crossed-out trash can symbol indicates that all types of batteries must not be discarded in standard trash, or at a trash site. Take the used batteries to a battery collection site according to your national legislation and the Batteries Directive 2006/66/EU.

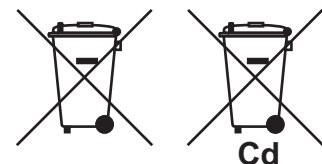

In the USA

The Mobius loop symbol (three chasing arrows) indicates that Ni-Cd and lead-acid rechargeable batteries must be recycled. Take the used batteries to a battery collection site according to local laws.

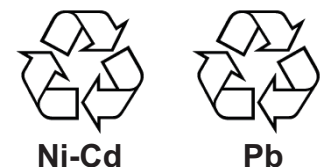



In the other countries



There are no international standards for the battery recycle symbol. The number of symbols can increase when the other countries make their own recycle symbols in the future.









SAFETY INSTRUCTIONS





The user and installer must read the appropriate safety instructions before attempting to install or operate the equipment.

 WARNING	Indicates a potentially hazardous situation which, if not avoided, could result in death or serious injury.
 CAUTION	Indicates a potentially hazardous situation which, if not avoided, may result in minor or moderate injury.





 Warning, Caution	 Prohibitive Action	 Mandatory Action
--	--	--

Safety instructions for the operator

 WARNING	
	Do not open the equipment. Only qualified personnel should work inside the equipment.
	Do not disassemble or modify the equipment. Fire, electrical shock or serious injury can result.
	Turn off the power immediately if the equipment is emitting smoke or fire. Fire or electrical shock can result if the power is left on.
	Turn off the power immediately if water leaks into the equipment or an object is dropped inside the equipment. Continued use can cause fire or electrical shock.
	Turn off the power immediately if you feel the equipment is acting abnormally. If the equipment is hot to the touch or is emitting strange noises, turn off the power immediately and contact your dealer for advice.





 WARNING	
	Do not operate the equipment with wet hands. Electrical shock can result.
	Do not place liquid-filled containers on the top of the equipment. Electrical shock can result.
	Do not install the equipment where it may be subjected to rain or water splash. Fire or electrical shock can result if water gets inside the equipment.
	Use the proper fuse. Use of a wrong fuse can damage the equipment and may cause fire.

A warning label is attached to the equipment. Do not remove this label. If the label is missing or illegible, contact a FURUNO agent or dealer about replacement.

 WARNING 
To avoid electrical shock, do not remove cover. No user-serviceable parts
 

Name: Warning Label (1)
Type: 86-003-1011-3
Code No.: 100-236-233-10

Safety instructions for the installer

 WARNING	
	<p>Do not open the equipment.</p> <p>Only qualified personnel should work inside the equipment.</p>
	<p>Turn off the power before beginning the installation.</p> <p>Fire or electrical shock can result if the power is left on.</p>
	<p>Be sure no water leaks at the transducer and temperature sensor.</p> <p>Water leakage can sink the vessel. Also, confirm that neither the transducer or sensor will loosen by vibration. The installer is solely responsible for the installation.</p>
	<p>Confirm that the power supply voltage is within the rating of this equipment.</p> <p>Incorrect voltage will damage the equipment and may cause fire.</p>





 CAUTION					
	<p>The transducer cable must be handled carefully, following the guidelines below.</p> <ul style="list-style-type: none"> • Keep fuels and oils away from the cable. • Locate the cable away from chemicals. • Locate the cable away from locations where it might be damaged. 				
	<p>Do not apply the power with the transducer exposed to air.</p> <p>Damage to the transducer may result.</p>				
	<p>Observe the following compass safe distances to prevent interference to a magnetic compass:</p> <table border="1" style="margin-left: auto; margin-right: auto;"> <tbody> <tr> <td style="padding: 5px;">Standard compass</td> <td style="padding: 5px;">Steering compass</td> </tr> <tr> <td style="text-align: center; padding: 5px;">0.95 m</td> <td style="text-align: center; padding: 5px;">0.60 m</td> </tr> </tbody> </table>	Standard compass	Steering compass	0.95 m	0.60 m
Standard compass	Steering compass				
0.95 m	0.60 m				

TABLE OF CONTENTS

FOREWORD	v
SYSTEM CONFIGURATION	vi
1. MOUNTING	1
1.1 Equipment Lists	1
1.2 Network Sounder	5
1.3 Transducer	5
1.4 Optional Speed/Temperature Sensors ST-02MSB, ST-02PSB	5
1.4.1 Mounting considerations	5
1.4.2 Mounting procedure	6
2. WIRING	7
2.1 Wiring Outline	7
2.2 Transducer Cable	8
3. INITIAL SETTINGS	11
3.1 Tap Setting	11
3.2 DIP Switch Setting	12
3.3 Operation Check	14
4. MAINTENANCE	15
4.1 Maintenance	15
4.2 Replacing the Fuse	16
4.3 Restoring Default Settings	16
APPENDIX 1 INSTALLATION OF TEMPERATURE SENSORS	AP-1
SPECIFICATIONS	SP-1
PACKING LIST	A-1
OUTLINE DRAWING	D-1
INTERCONNECTION DIAGRAM	S-1

FOREWORD

A Word to the Owner of the DFF3

Congratulations on your choice of the FURUNO DFF3 Network Sounder. We are confident you will see why the FURUNO name has become synonymous with quality and reliability.

Since 1948, FURUNO Electric Company has enjoyed an enviable reputation for quality marine electronics equipment. This dedication to excellence is furthered by our extensive global network of agents and dealers.

This equipment is designed and constructed to meet the rigorous demands of the marine environment. However, no machine can perform its intended function unless operated and maintained properly. Please carefully read and follow the recommended procedures for operation and maintenance.

Thank you for considering and purchasing FURUNO.

Features

The DFF3 network sounder is a dual frequency echo sounder designed for use with the FURUNO NavNet, NavNet vx2, NavNet 3D and NavNet TZtouch series. The DFF3 feeds data about underwater conditions via a LAN.

- FURUNO Free Synthesizer (FFS) transceiver design allows use of user-selectable operating frequencies (28 - 200 kHz).
- Automatic operation selects correct range and gain to show fish echoes and bottom in both shallow and deep waters.
- Improved discrimination of near-surface fish by eliminating the transmission line.
- Heaving compensation* stabilizes the picture against ship's pitching and rolling. * Requires NavNet 3D/TZtouch display device plus Satellite Compass SC-30.
- The ACCU-FISH™ feature identifies individual fish with size or depth indications and a fish symbol. (Requires connection to a 20/200-1T transducer. Available only with NavNet3D or TZTouch.)
- 1/2/3 kW output

Note: The terms "NavNet", NavNet vx2", "NavNet 3D" and "NavNet TZtouch" refer to the models listed below.

NavNet/NavNet vx2	NavNet 3D	NavNet TZtouch
Model 17x2 Series, Model 17x2C Series, Model 17x4 Series, Model 17x4C Series, GD-1720, GD-1720C, Model 18x3C(-BB) Series, Model 18x4C(-BB) Series, Model 19x3C(-BB) Series, Model 19x4C(-BB) Series, GD-1900C(-BB), GD-1920C(-BB)	MFD8/12/BB	TZ9, TZ14

CE/UKCA declaration

With regards to CE/UKCA declarations, please refer to our website (www.furuno.com) for further information about RoHS conformity declarations.

Disclosure of Information about China RoHS

With regards to China RoHS information for our products, please refer to our website (www.furuno.com).

SYSTEM CONFIGURATION

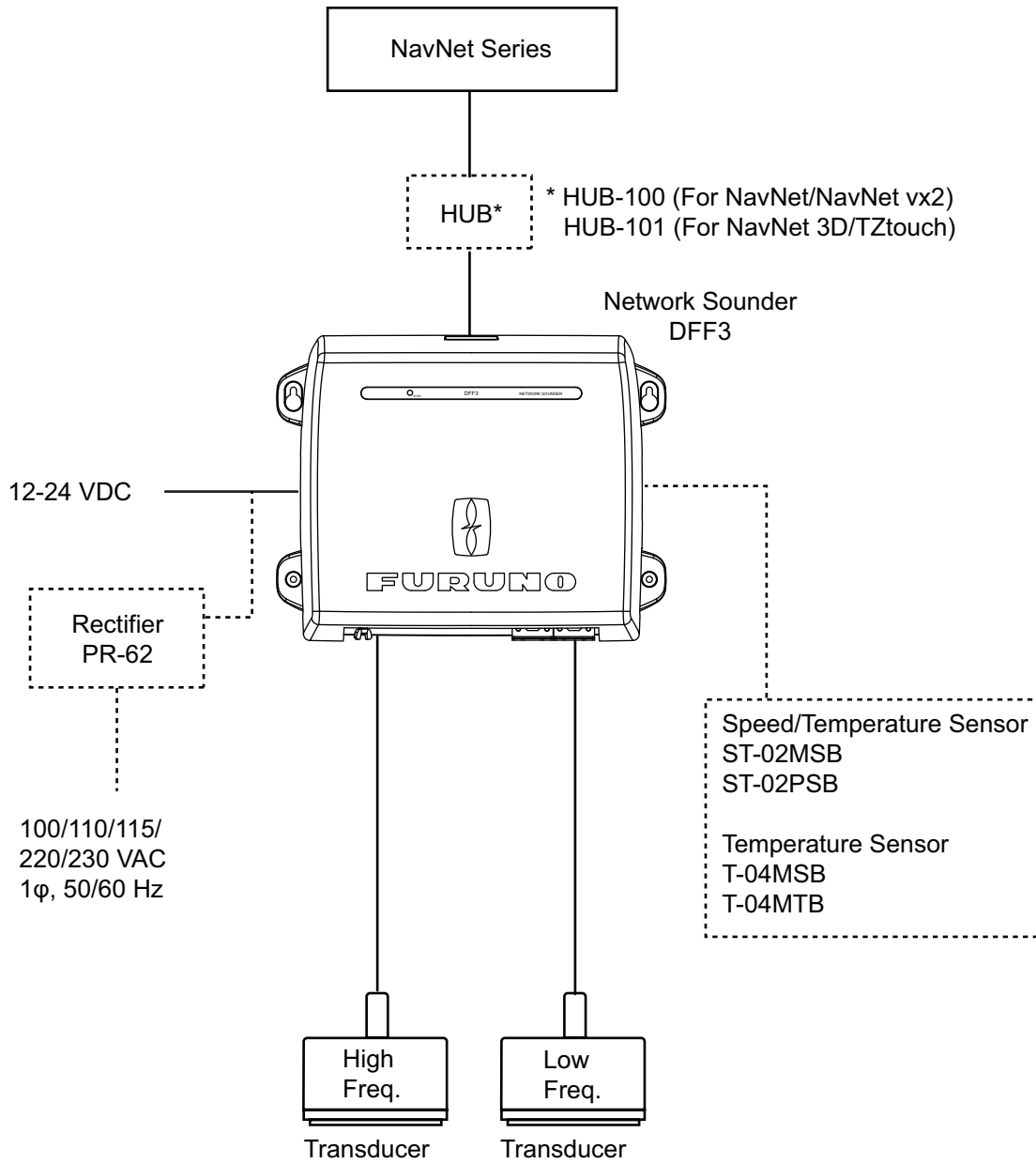

1. MOUNTING

1.1 Equipment Lists

Standard supply

Name	Type	Code No.	Qty	Remarks
Network Sounder	DFF3	—	1	
Spare Parts	SP02-05601	001-033-740	1 set	Fuse
Installation Materials	CP02-08500	000-011-917	1 set	- Power cable (3.5 m) - LAN cable (5 m) - Self-tapping screws

Optional supply

Name	Type	Code No.	Remarks
Transducer	1/2/3kW available. See next page for choices.	—	
Thru-hull pipe		—	
Tank		—	
Cable Assembly	MJ-A6SPF0017-010C	001-159-704-10	1 m, for NavNet
	MJ-A6SPF0017-050C	001-159-705-10	5 m, for NavNet
	MJ-A6SPF0017-100C	001-159-706-10	10 m, for NavNet
	MJ-A6SPF0017-200C	001-159-707-11	20 m, for NavNet
	MJ-A6SPF0017-300C	001-159-708-11	30 m, for NavNet
	MOD-Z072-020+	000-167-175-10	2 m, for HUB-101
	MOD-Z072-100+	001-167-177-10	10 m, for HUB-101
Speed/Temperature Sensor	ST-02MSB	000-137-986	Thru-hull mount, steel hull
	ST-02PSB	000-137-987	Thru-hull mount, plastic hull
Temperature Sensor	T-04MSB	000-026-893	Thru-hull mount
	T-04MTB	000-026-894	Transom mount
Rectifier	PR-62	000-013-484	100 VAC
		000-013-485	110 VAC
		000-013-486	220 VAC
		000-013-487	230 VAC

1. MOUNTING

Transducer, thru-hull pipe and tank combinations

The contents in the table below are for your information only. Some tanks are not RoHS compliant.

Output (W)	Frequency (kHz)	Ship type	Transducer	Thru-hull pipe	Tank	
1k/1k	28/50	Steel	28F-8	TWB-6000(2)	T-656	
		FRP	50B-9B	-	-	
	28/88	Steel	28F-8	TWB-6000(2)	T-657	
		FRP	88B-8	-	-	
	50/88	Steel	50B-9B	TWB-6000(2)	T-658	
		FRP	88B-8	-	-	
	50/200	Steel	50/200-1T*	TFB-5000(1)	T-603	
		FRP		TRB-1000(1) or TRB-1200	T-603-F	
1k/2k	28/200	Steel	28F-8	TWB-6000(2)	T-657	
		FRP	200B-8/8B	-	-	
	50/200	Steel	50B-9B	TWB-6000(2)	T-658	
		FRP	200B-8/8B	-	-	
	88/200	Steel	88B-8	TWB-6000(2)	T-659	
		FRP	200B-8/8B	-	-	
2k/2k	28/200	Steel	28BL-6HR 200B-8/8B	TFB-7000(2) or TWB-6000(2)	T-693	
		FRP		TRB-1100(2) or TWB-6000(2)	T-693-F	
	38/200	Steel	38BL-9HR 200B-8/8B	TFB-7000(2) or TWB-6000(2)	T-693	
		FRP		TRB-1100(2) or TWB-6000(2)	T-693-F	
	50/200	Steel	50BL-12HR 200B-8/8B	TFB-7000(2) or TWB-6000(2)	T-693	
		FRP		TRB-1100(2) or TWB-6000(2)	T-693-F	
	82/200	Steel	82B-35R 200B-8/8B	TFB-7000(2) or TWB-6000(2)	T-649	
		FRP		TRB-1100(2)	T-649-F	
	88/200	Steel	88B-10 200B-8/8B	TFB-7000(2) or TWB-6000(2)	T-649	
		FRP		TRB-1100(2)	T-649-F	
	3k/2k	68/200	Steel	68F-30H 200B-8/8B	TFB-7000(2) or TWB-6000(2)	T-647
			FRP		TRB-1100(2)	T-647-F
107/200		Steel	100B-10R 200B-8/8B	TFB-7000(2) or TWB-6000(2)	T-649	
		FRP		TRB-1100(2)	T-649-F	
3k/3k	28/38	Steel	28BL-12HR 38BL-15HR	TFB-7000(2) or TWB-6000(2)	T-681	
		FRP		TRB-1100(2)	T-681-F	
	28/50	Steel	28BL-12HR 50BL-24HR	TFB-7000(2) or TWB-6000(2)	T-681	
		FRP		TRB-1100(2)	T-681-F	

Output (W)	Frequency (kHz)	Ship type	Transducer	Thru-hull pipe	Tank
3k/3k (con't)	28/88	Steel	28BL-12HR 88F-126H	TFB-7000(2) or TWB-6000(2)	T-682
		FRP		TRB-1100(2)	T-682-F
	28/150	Steel	28BL-12HR 150B-12H	TFB-7000(2) or TWB-6000(2)	T-683
		FRP		TRB-1100(2)	T-683-F
	28/200	Steel	28BL-12HR 200B-12H	TFB-7000(2) or TWB-6000(2)	T-683
		FRP		TRB-1100(2)	T-683-F
	38/50	Steel	38BL-15HR 50BL-24HR	TFB-7000(2) or TWB-6000(2)	T-681
		FRP		TRB-1100(2)	T-681-F
	38/88	Steel	38BL-15HR 88F-126H	TFB-7000(2) or TWB-6000(2)	T-682
		FRP		TRB-1100(2)	T-682-F
	38/150	Steel	38BL-15HR 150B-12H	TFB-7000(2) or TWB-6000(2)	T-683
		FRP		TRB-1100(2)	T-683-F
	38/200	Steel	38BL-15HR 200B-12H	TFB-7000(2) or TWB-6000(2)	T-683
		FRP		TRB-1100(2)	T-683-F
	50/88	Steel	50BL-24HR 88F-126H	TFB-7000(2) or TWB-6000(2)	T-682
		FRP		TRB-1100(2)	T-682-F
	50/150	Steel	50BL-24HR 150B-12H	TFB-7000(2) or TWB-6000(2)	T-683
		FRP		TRB-1100(2)	T-683-F
	50/200	Steel	50BL-24HR 200B-12H	TFB-7000(2) or TWB-6000(2)	T-683
		FRP		TRB-1100(2)	T-683-F
	68/150	Steel	68F-30H 150B-12H	TFB-7000(2) or TWB-6000(2)	T-646
		FRP		TRB-1100(2)	T-646-F
	68/200	Steel	68F-30H 200B-12H	TFB-7000(2) or TWB-6000(2)	T-646
		FRP		TRB-1100(2)	T-646-F
88/150	Steel	88F-126H 150B-12H	TFB-7000(2) or TWB-6000(2)	T-685	
	FRP		TRB-1100(2)	T-685-F	
88/200	Steel	88F-126H 200B-12H	TFB-7000(2) or TWB-6000(2)	T-685	
	FRP		TRB-1100(2)	T-685-F	

1. MOUNTING

Output (W)	Frequency (kHz)	Ship type	Transducer	Thru-hull pipe	Tank	
1k	28	Steel	28F-8	TFB-5000(1)	T-604	
		FRP		TRB-1000(1) or TRB-1200	T-604-F	
	50	Steel	50B-6/6B	TFB-5000(1)	T-605	
		FRP		TRB-1000(1)	T-605-F	
		Steel	50B-9B	TFB-5000(1)	T-603	
		FRP		TRB-1000(1) or TRB-1200	T-603-F	
	68	Steel	68F-8H	TFB-5000(1)	T-621	
		FRP		TRB-1000(1) or TRB-1200	T-621-F	
	88	Steel	88B-8	TFB-5000(1)	T-606	
		FRP		TRB-1000(1) or TRB-1200	T-606-F	
	200	Steel	200B-5S	TFB-5000(1)	T-605	
		FRP		TRB-1000(1)	T-605-F	
	2k	28	Steel	28BL-6HR	TFB-5000(1)	T-702
			FRP		TRB-1000(1)	T-702-F
38		Steel	38BL-9HR	TFB-5000(1)	T-702	
		FRP		TRB-1000(1)	T-702-F	
50		Steel	50BL-12HR	TFB-5000(1)	T-702	
		FRP		TRB-1000(1)	T-702-F	
82		Steel	82B-35R	TFB-5000(1)	T-609	
		FRP		TRB-1000(1) or TRB-1200	T-609-F	
88		Steel	88B-10	TFB-5000(1)	T-609	
		FRP		TRB-1000(1) or TRB-1200	T-609-F	
200		Steel	200B-8/8B	TFB-5000(1)	T-608	
		FRP		TRB-1000(1) or TRB-1200	T-608-F	
3k		28	Steel	28BL-12HR	TFB-4000(1)	T-616
			FRP		TRB-1000(1)	T-616-F
	38	Steel	38BL-15HR	TRB-4000(1)	T-616	
		FRP		TRB-1000(1)	T-616-F	
	50	Steel	50BL-24HR	TFB-4000(1)	T-616	
		FRP		TRB-1000(1)	T-616-F	
	68	Steel	68F-30H	TFB-5000(1)	T-614	
		FRP		TRB-1000(1)	T-614-F	
	88	Steel	88F-126H	TFB-4000(1)	T-618	
		FRP		TRB-1000(1)	T-618-F	
	107	Steel	100B-10R	TFB-5000(1)	T-609	
		FRP		TRB-1000(1) or TRB-1200	T-609-F	
	150	Steel	150B-12H	TFB-5000(1)	T-615	
		FRP		TRB-1000(1)	T-615-F	
200	Steel	200B-12H	TFB-5000(1)	T-615		
	FRP		TRB-1000(1)	T-615-F		

*: ACCU-FISH™ compatible.

1.2 Network Sounder

The network sounder can be installed on a desktop, deck or on a bulkhead. When selecting a mounting location for the network sounder, keep the following in mind:

- The temperature and humidity at the mounting site should be moderate and stable.
- Locate the unit away from exhaust pipes and vents.
- The mounting location should be well ventilated.
- Mount the unit where shock and vibration are minimal.
- Keep the unit away from electromagnetic field-generating equipment such as motors and generators.
- Leave slack in cables for maintenance and servicing ease.
- A magnetic compass will be affected if the network sounder is placed too close to it. Observe the compass safe distances noted in the safety instructions to prevent disturbance to the magnetic compass.

Fasten the network sounder to the mounting location with four self-tapping screws (5×20), referring to the outline drawing at the back of this manual for mounting dimensions.

1.3 Transducer

The performance of the echo sounder largely depends upon the transducer position. Select a place least affected by air bubbles since turbulence blocks the sounding path. Further, select a place least influenced by engine noise. It is known that air bubbles are fewest at the place where the bow first falls and the next wave rises, at usual cruising speed.

Note: The face of the transducer must be facing the sea bottom in normal cruising trim of the boat.

1.4 Optional Speed/Temperature Sensors ST-02MSB, ST-02PSB

1.4.1 Mounting considerations

- Select a mid-boat flat position. The sensor does not have to be installed perfectly perpendicular. However, the sensor must not be damaged in dry-docking operation.
- Select a place apart from equipment generating heat.
- Select a place in the forward direction viewing from the drain hole, to allow for circulation of cooling water.
- Select a place free from vibration.
- Do not install near the transducer of an echo sounder, to prevent interference to the echo sounder.

1. MOUNTING

1.4.2 Mounting procedure

1. Dry dock the boat.
2. Make a hole of approx. 51 mm in diameter in the mounting location.
3. Unfasten locknut and remove the sensor section.
4. Apply high-grade sealant to the flange of the sensor.
5. Pass the sensor casing through the hole.
6. Face the notch on the sensor toward boat's bow and tighten the flange.
7. Set the sensor section to the sensor casing and tighten the locknut.
8. Launch the boat and check for water leakage around the sensor.

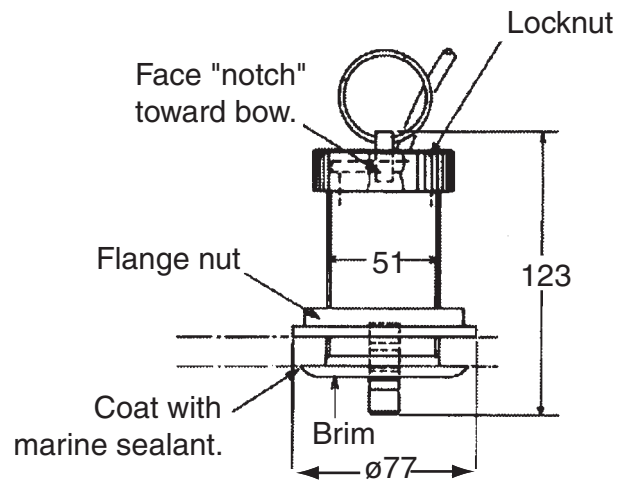

2. WIRING

2.1 Wiring Outline

Connect the power cable, transducer cables, sensor cable, network cable and ground wire to their respective locations on the network sounder. See the next page for how to connect the transducer cables.

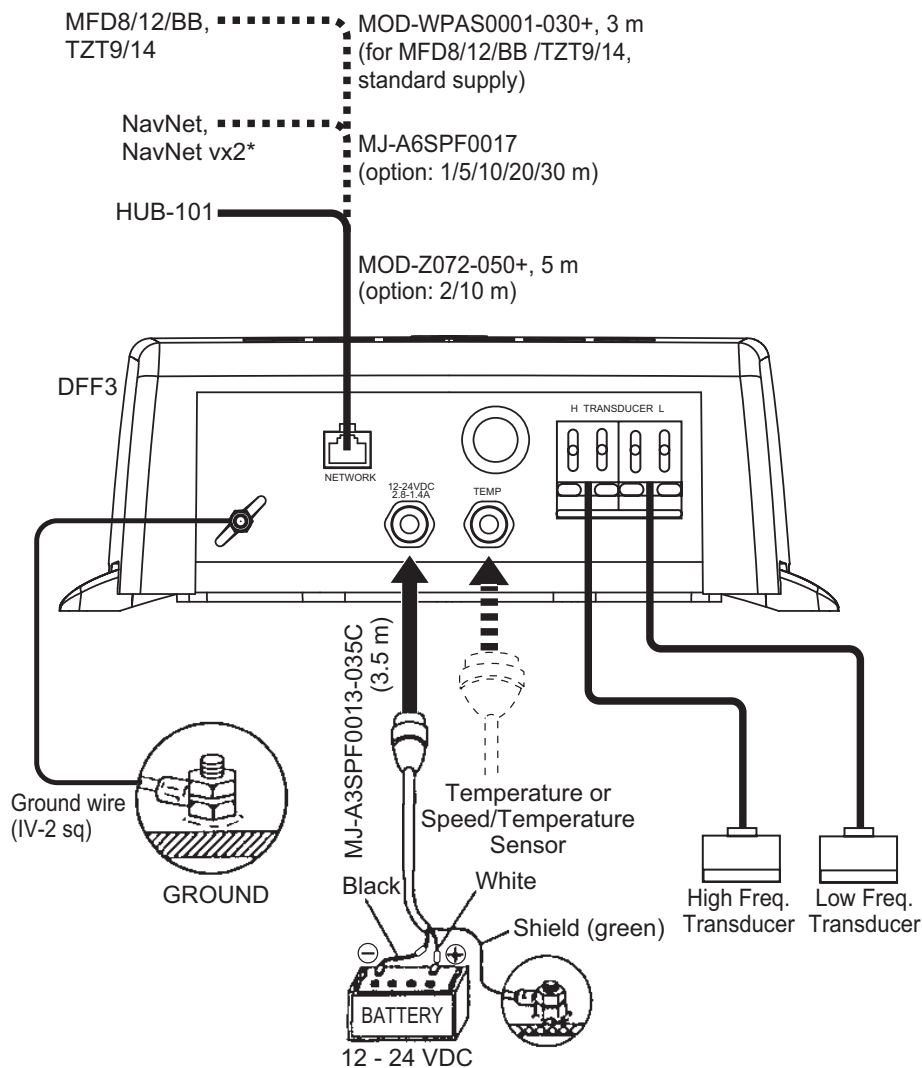

Model 17x2 Series, Model 17x2C Series, Model 17x4 Series, Model 17x4C Series, GD-1720, GD-1720C, Model 18x3C(-BB) Series, Model 18x4C(-BB) Series, Model 19x3C(-BB) Series, Model 19x4C(-BB) Series, GD-1900C(-BB), GD-1920C(-BB)

Ground

Connect a ground wire (IV-2 sq, local supply) between the ground terminal and ship's ground to prevent interference to the sounder picture. Make the length of the wire as short as possible. For FRP vessels, install a ground plate that measures about 20 cm by 30 cm on the outside of the hull bottom and connect the ground wire there.

	CAUTION
	Ground the equipment to prevent mutual interference.

2. WIRING

Multiple network sounders

Two DFF3 units may be connected by using HUB-101.

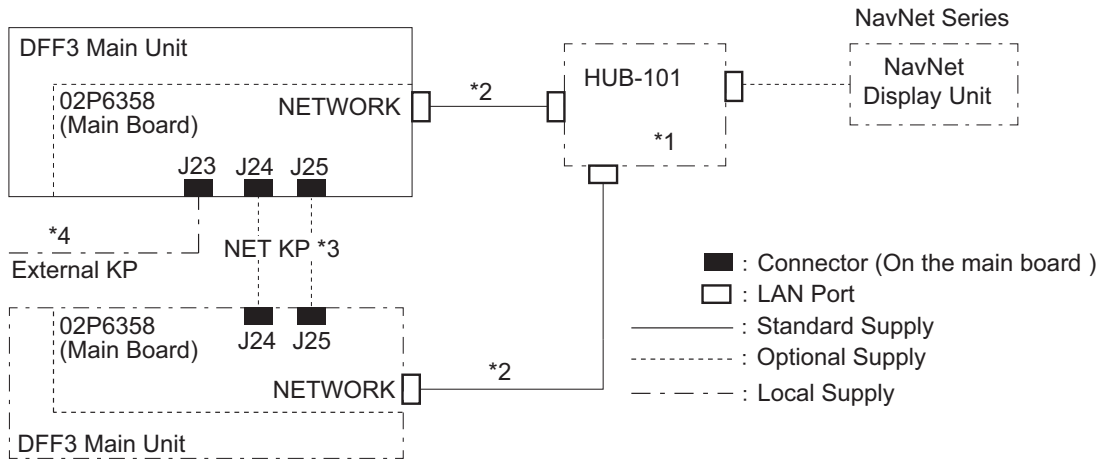

- *1 = One NavNet series radar and two NavNet display units may be connected to HUB-101.
- *2 = MOD-Z072-050+, 5 m (2/10 m: optional supply)
- *3 = Connect to NET KP to get best performance. Either J24 or J25 can be used but connect to same number.
- *4 = If an external KP (Keying Pulse) is required, ask a FURUNO dealer.

2.2 Transducer Cable

TD-ID transducer cable

- TD-ID transducer cannot be used with NavNet, NavNet vx2.
- TD-ID transducer cannot be used with non-TD-ID transducer.
- Connect single TD-ID transducer to low frequency WAGO connector, regardless of actual frequency.

Cable fabrication

Fabricate the transducer cable as shown below. Separate the transducer cable well away from other electric cables to prevent interference to the sounder. This is especially important in the case of power cables from televisions and monitors.

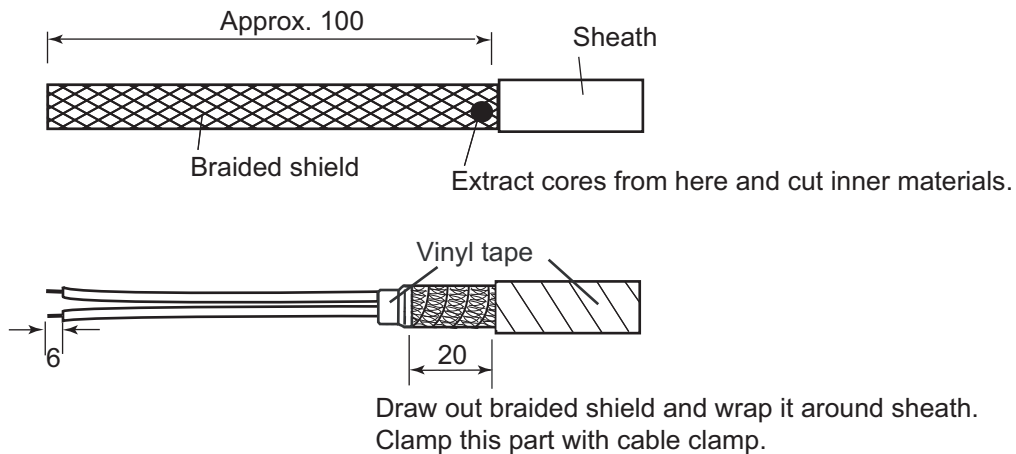

Cable connection

After fabricating the transducer cable, connect the transducer cables to the equipment with WAGO connectors.

1. Open the cover: Grasp the cover at two sides, spread cover slightly and lift.
2. Unfasten six screws to remove the shield cover.
3. Detach the two WAGO connectors (low and high frequency) inside the equipment.

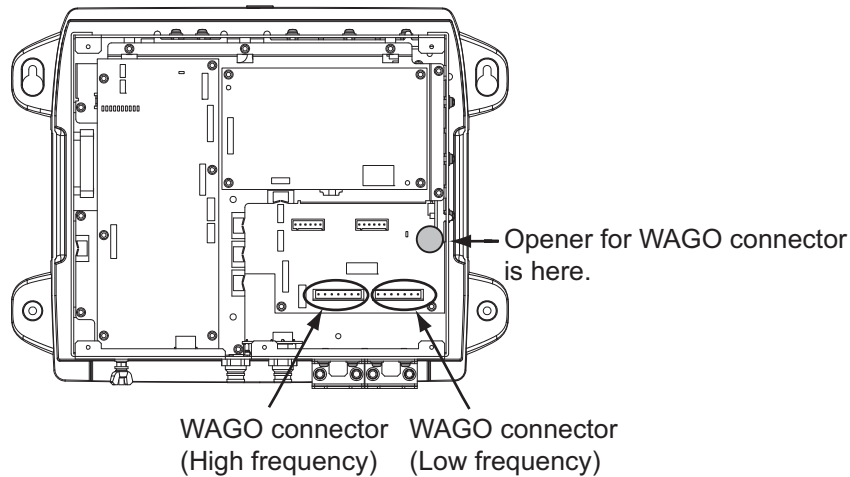

4. Connect the transducer cable to the WAGO connector, following the instructions in the figure below and the interconnection diagram. (The opener for the WAGO connector is attached inside the equipment. See the figure above.)

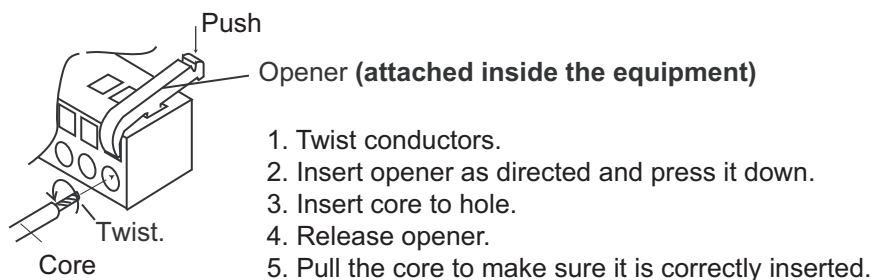

5. Unfasten the two screws labeled Screw A in the figure below.
6. Loosen the two screws labeled Screw B and slide cable clamp upward.

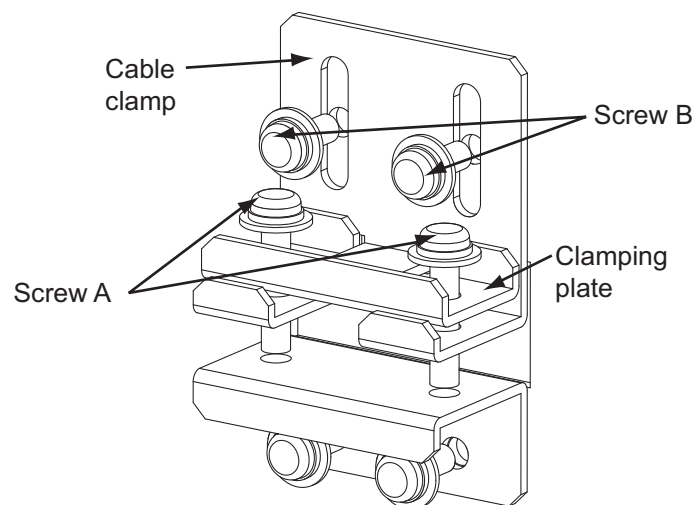

2. WIRING

7. Pass the transducer cables through the cable entrance and connect their WAGO connectors to respective terminals inside the equipment.
8. Slide the cable clamp downward and tighten screws B and A in that order to fasten the cable clamp.

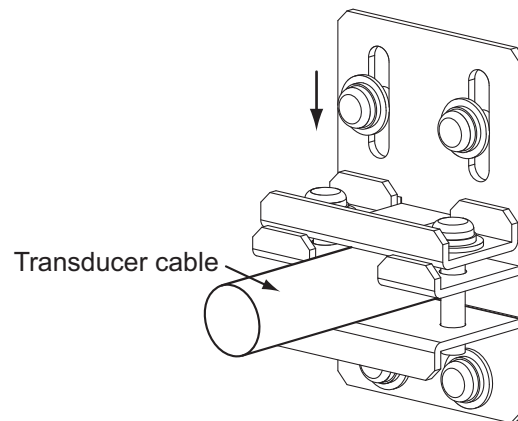

3. INITIAL SETTINGS

⚠ **WARNING**



Do not open the equipment unless totally familiar with electrical circuits.

Only qualified personnel should work inside the equipment.

3.1 Tap Setting

This equipment is preprogrammed for use with certain transducers. A jumper wire inside the equipment is set according to transducer model. Check the jumper wire setting instructions on the sticker attached to the chassis. Use the opener attached inside the unit to set the jumper wire. One end of the jumper wire is connected to COMMON; connect the other end to A - E in the jumper block as applicable.

For transducers not programmed, for example, Airmar make TD-ID transducer, consult a FURUNO agent or dealer for advice.

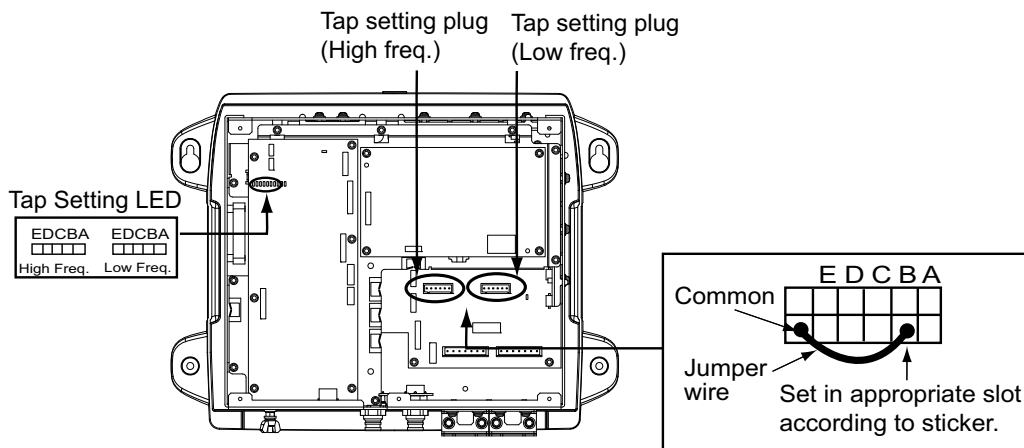

The following table shows the transducers programmed in the FCV-1150.

Type	Output (kW)	Tap	Type	Output (kW)	Tap
28F-8 ^{*1}	1	B	50BL-24HR ^{*1}	3	D
28BL-6HR ^{*1}	2	A	50F-24H	3	B
28F-18	2	B	68F-8H ^{*1}	1	A
28BL-12HR ^{*1}	3	A	68F-30H ^{*1}	3	B
28F-24H	3	D	82B-35R ^{*1}	2	E
38BL-9HR ^{*1}	2	B	88B-8 ^{*1}	1	D
38BL-15HR ^{*1}	3	D	88B-10 ^{*1}	2	C
50B-6B ^{*1}	1	A	88F-126H ^{*1}	3	E

3. INITIAL SETTINGS

Type	Output (kW)	Tap	Type	Output (kW)	Tap
50/200-1T* ² (50 kHz)	1	B	100B-10R* ¹	3	E
50/200-1ST (50 kHz)	1	B	150B-12H* ¹	3	C
50B-9B* ¹	1	A	200B-5S* ¹	1	D
50B-12	2	A	50/200-1T* ² (200 kHz)	1	C
50BL-12	2	A	50/200-1ST (200 kHz)	1	A
50BL-12HR* ¹	2	B	200B-8B* ¹	2	C
50BL-24H	3	D	200B-12H* ¹	3	C

*1: Available as an optional extra.

*2: Compatible with ACCU-FISH™ (available as an optional extra).

Note 1: For NavNet, the tap settings shown on the NETWORK SOUNDER SETUP are different from actual ones. Therefore, follow the instructions on the sticker inside the equipment.

Note 2: For transducers 50/200-1T, use the tap settings for 50/200-1T (50: Tap B, 200: Tap C).

3.2 DIP Switch Setting

The DIP switch S2 sets up the system according to the equipment connected. The DIP switch S3 should not be adjusted; leave all switches in the OFF position. Set DIP switch S2 referring to the figure below.

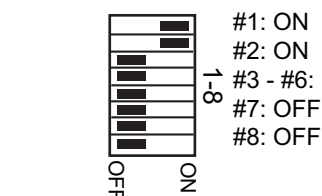
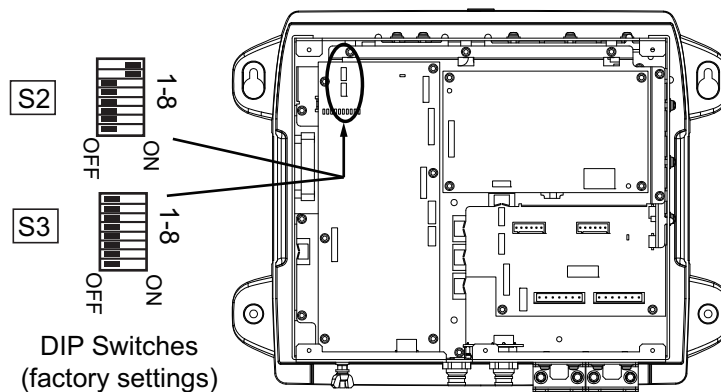

DIP Switch S2 settings for
NavNet, NavNet vx2,
NavNet TZtouch/TZtouch2

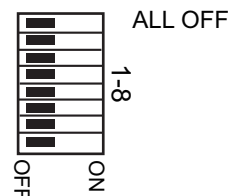

DIP Switch S2 settings for
NavNet 3D

DIP switch S2 description

Switch No.	Function	Setting
1	Power on/off by NavNet equipment	OFF: Power sync (for NavNet 3D)* ON: No power sync (for NavNet/NavNet vx2/ NavNet TZtouch)
2	Automatic/Manual IP address selection	OFF: Automatic IP address assignment. Use this setting for NavNet/NavNet vx2/NavNet TZtouch. ON: Manual IP address assignment. Use this setting for NavNet/NavNet vx2/NavNet TZtouch and refer to the table on the next page for IP addresses.
3 - 6	Manual IP address assignment	Valid when switch no. 2 is ON. For connection of multiple network sounders, assign each one an IP address with the Mode DIP switch, referring to the table on the next page.
7	Restore default settings (other than LAN and transducer)	See section 4.3.
8	Restore ALL default settings	See section 4.3.

*: Power sync setting enabled at NavNet 3D.

DIP SW S2 setting, sounder and IP address

SW No.3	SW No.4	SW No.5	SW No.6	Host Name	IP Address
OFF	OFF	OFF	OFF	SOUNDER	172.031.092.001
ON	OFF	OFF	OFF	SOUNDER1	172.031.092.011
OFF	ON	OFF	OFF	SOUNDER2	172.031.092.012
ON	ON	OFF	OFF	SOUNDER3	172.031.092.013
OFF	OFF	ON	OFF	SOUNDER4	172.031.092.014
ON	OFF	ON	OFF	SOUNDER5	172.031.092.015
OFF	ON	ON	OFF	SOUNDER6	172.031.092.016
ON	ON	ON	OFF	SOUNDER7	172.031.092.017
OFF	OFF	OFF	ON	SOUNDER8	172.031.092.018
ON	OFF	OFF	ON	SOUNDER9	172.031.092.019
OFF	ON	OFF	ON		
ON	ON	OFF	ON		
OFF	OFF	ON	ON		
ON	OFF	ON	ON		
OFF	ON	ON	ON		
ON	ON	ON	ON		

3. INITIAL SETTINGS

Transducer setting at NavNet series

After setting up the transducer at the DFF3, set transducer type at NavNet 3D/TZtouch. See respective Installation Manual for the procedure.

3.3 Operation Check

For NavNet, NavNet vx2 and NavNet TZtouch, the DFF3 is powered on/off from ship's switch-board. For NavNet 3D, it is powered on/off from the display unit. The LED on the cover of the DFF3 lights or blinks according to equipment state, as described in the table below.

LED state and meaning

LED state	Meaning
Lit continuously	<ul style="list-style-type: none">• Standby state. (If, for NavNet series, no signal is received via LAN for more than 10 minutes, the equipment automatically goes into standby to lessen power consumption.)• Power on (20 seconds during initialization)• IP address not set
Blinking every two seconds	Normal operation
Blinking every 0.4 seconds	Transducer settings at NavNet series not properly set.

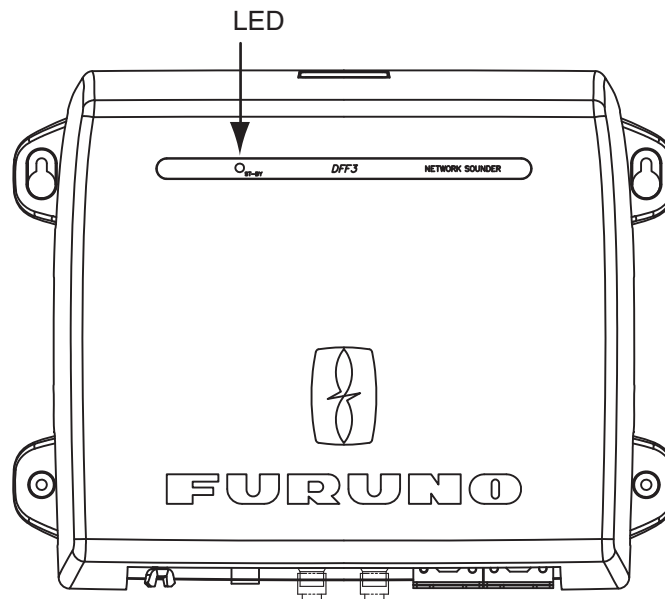

4. MAINTENANCE

WARNING



ELECTRICAL SHOCK HAZARD
Do not open the equipment.



Only qualified personnel should work inside the equipment.

NOTICE

Do not apply paint, anti-corrosive sealant or contact spray to coating or plastic parts of the equipment.

Those items contain organic solvents that can damage coating and plastic parts, especially plastic connectors.

4.1 Maintenance

Regular maintenance is essential for good performance. Check the items listed in the table below at the suggested interval to help keep your equipment in good shape for years to come.

Item	Check point, action	Check interval
Transducer cables	Check that cables are tightly fastened and are not damaged. Refasten if necessary. Replace if damaged.	Once a month
Power cable, sensor cable	Check that these cables are tightly fastened and not damaged. Refasten if necessary. Replace if damaged.	Once a month
Ground	Check for corrosion. Clean if necessary.	Once a month
Power supply voltage	Check voltage. If out of rating correct problem.	Once a month
Cleaning the network sounder's cabinet	Dust or dirt on the cabinet may be removed with a dry cloth. Do not use chemical-based cleaners to clean the cabinet; they can remove markings and damage the cabinet.	Once a month
Transducer	Marine life on the transducer face will result in a gradual decrease in sensitivity. Check the transducer face for cleanliness each time the boat is dry-docked. Carefully remove any marine life with a piece of wood or fine-grade sandpaper.	When vessel is dry-docked

4.2 Replacing the Fuse

The 5 A fuse (Type: FGBO-A 125V 5A PBF, Code No. 000-155-853-10) in the snap-in fuse holder on the power cable protects the equipment from equipment fault and reverse polarity of the ship's mains. If the equipment cannot be powered, the fuse may have blown. Find out the cause for blown fuse before replacing it. If the fuse blows again after replacement, contact a FURUNO agent or dealer for advice.

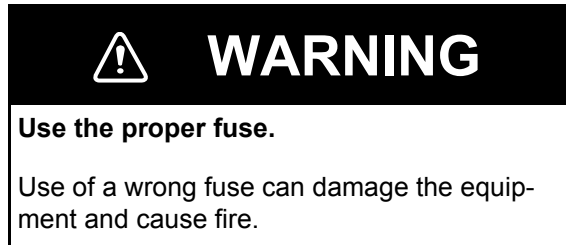

4.3 Restoring Default Settings

This procedure restores all default sounder settings on the NavNet series. You can restore all default settings or restore those other than transducer and LAN. This procedure should only be performed by a suitably qualified FURUNO technician.

1. Disconnect the power and LAN cables from the DFF3.
2. Turn on the #1 and #2 switches of the Mode switch. See section 3.2 for the location.
3. Turn on the #7 or #8 switch of the Mode switch as applicable.
#7: Restore default settings other than LAN and transducer.
#8: Restore all default settings. Use this when changing transducers.
4. Reconnect the power cable and LAN cable to the DFF3, and turn on the power at the ship's switchboard.
5. The LED blinks (every four seconds) when default settings are completely restored.

APPENDIX 1 INSTALLATION OF TEMPERATURE SENSORS

The installation instructions in this chapter are copied from the manufacturer's (AIRMAR Technology Corporation) installation guide, which is included with your sensor. The model numbers mentioned within the documentation should be read as follows:
T42 => T-04MSB
T80 => T-04MTB

OWNER'S GUIDE & INSTALLATION INSTRUCTIONS

Thru-Hull, Analog High-Precision Temperature Sensor

Model T42

Record the information found on the cable tag for future reference.

Part No. _____ Date _____

05/28/14

17-437-02 rev. 01

Follow the precautions below for optimal product performance and to reduce the risk of property damage, personal injury, and/or death.

WARNING: Always wear safety goggles and a dust mask when installing.

WARNING: Immediately check for leaks when the boat is placed in the water. Do not leave the boat unchecked for more than three hours. Even a small leak can allow considerable water to accumulate.

CAUTION: Never install a bronze sensor in a metal hull because electrolytic corrosion will occur.

CAUTION: Never install a metal sensor on a vessel with a positive ground system.

CAUTION: Never pull, carry, or hold the sensor by its cable; this may sever internal connections.

CAUTION: Never use solvents. Cleaner, fuel, sealant, paint, and other products may contain solvents that can damage plastic parts, especially the sensor's face.

IMPORTANT: Read the instructions completely before proceeding with the installation. These instructions supersede any other instructions in your instrument manual if they differ.

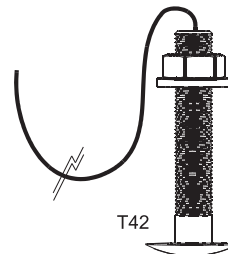

Tools & Materials

Safety goggles

Dust mask

Electric drill

Drill bit/hole saw/spade bit:

Pilot hole	3mm or 1/8"
T42	22mm or 7/8"

Sandpaper

Mild household detergent or weak solvent (alcohol)

Marine sealant (suitable for below waterline)

Slip-joint pliers

Installation in a cored fiberglass hull (see page 2)

Hole saw for hull interior: 30mm or 1-1/4"

Cylinder, wax, tape, and casting epoxy

Water-based anti-fouling paint (**mandatory in salt water**)

Sensor Installation

Hole Drilling

Cored fiberglass hull — Follow separate instructions on page 2.

1. Drill a 3mm or 1/8" pilot hole from inside the hull. If there is a rib, strut, or other hull irregularity near the selected mounting location, drill from the outside.
2. Using the appropriate drill bit, cut a hole perpendicular to the hull from outside the boat.
3. Sand and clean the area around the hole, inside and outside, to ensure that the marine sealant will adhere properly to the hull. If there is any petroleum residue inside the hull, remove it with either mild household detergent or a weak solvent (alcohol) before sanding.

Applications

- Bronze sensor recommended for fiberglass or wood hull only.
- The hull must be a minimum of 8mm (5/16") thick at the mounting location.

Mounting Location

Choose a location where the temperature sensor will be in contact with the water at all times.

APPENDIX 1 INSTALLATION OF TEMPERATURE SENSORS

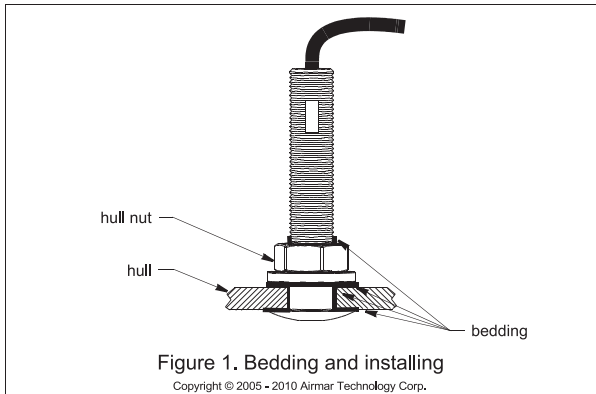

Bedding

CAUTION: Be sure all surfaces to be bedded are clean and dry.

1. Remove the hull nut (see Figure 1).
2. Apply a 2 mm (1/16") thick layer of marine sealant around the flange of the sensor that will contact the hull and up the stem. The sealant must extend 6 mm (1/4") higher than the combined thickness of the hull and the hull nut. This will ensure that there is marine sealant in the threads to seal the hull and hold the hull nut securely in place.
3. Apply a 2 mm (1/16") thick layer of marine sealant to the flange of the hull nut that will contact the hull.

Installing

1. From outside the hull, thread the cable through the mounting hole.
2. Push the sensor into the mounting hole using a twisting motion to squeeze out excess marine sealant (see Figure 1).
3. From inside the hull, slide the hull nut onto the cable. Screw the hull nut in place. Tighten it with slip-joint pliers.

Cored fiberglass hull—Do not over tighten, crushing the hull.

Wood hull—Allow for the wood to swell before tightening.

4. Remove any excess marine sealant on the outside of the hull to ensure smooth water flow over the sensor.

Checking for Leaks

When the boat is placed in the water, **immediately** check around the thru-hull sensor for leaks. Note that very small leaks may not be readily observed. Do not leave the boat in the water for more than 3 hours before checking it again. If there is a small leak, there may be considerable bilge water accumulation after 24 hours. If a leak is observed, repeat "Bedding" and "Installing" **immediately** (see page 2).

Cable Routing & Connecting

CAUTION: If the sensor came with a connector, do not remove it to ease cable routing. If the cable must be cut and spliced, use Airmar's splash-proof Junction Box No. 33-035 and follow the instructions supplied. Removing the waterproof connector or cutting the cable, except when using a water-tight junction box, will void the sensor warranty.

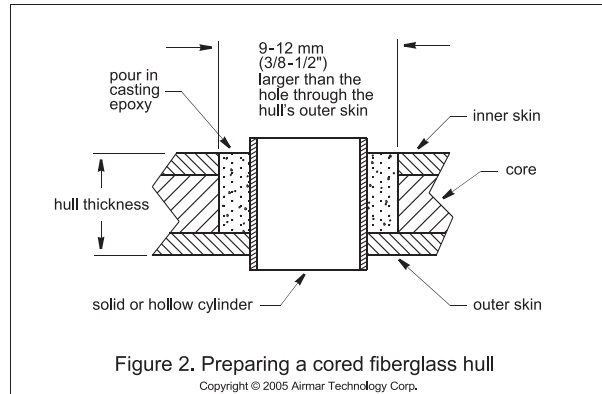

1. Route the cable to the instrument being careful not to tear the cable jacket when passing it through the bulkhead(s) and other parts of the boat. Use grommet(s) to prevent chafing. To reduce electrical interference, separate the transducer cable from other electrical wiring and the engine. Coil any excess cable and secure it in place with cable ties to prevent damage.
2. Refer to the instrument owner's manual to connect the transducer to the instrument.

Installation in a Cored Fiberglass Hull

The core (wood or foam) must be cut and sealed carefully. The core must be protected from water seepage, and the hull must be reinforced to prevent it from crushing under the hull nut allowing the sensor to become loose.

CAUTION: Completely seal the hull to prevent water seepage into the core.

1. Drill a 3 mm or 1/8" pilot hole from inside the hull. If there is a rib, strut, or other hull irregularity near the selected mounting location, drill from the outside. (If the hole is drilled in the wrong location, drill a second hole in a better location. Apply masking tape to the outside of the hull over the incorrect hole and fill it with epoxy.)
2. Using the 21 mm or 7/8" drill bit, cut a hole from outside the hull through the *outer* skin only (see Figure 2).
3. From inside the hull using the 30mm or 1-1/4" hole saw, cut through the *inner* skin and most of the core. The core material can be very soft. Apply only light pressure to the hole saw after cutting through the inner skin to avoid accidentally cutting the *outer* skin.
4. Remove the plug of core material so the *inside* of the outer skin and the inner core of the hull is fully exposed. Clean and sand the inner skin, core, and the outer skin around the hole.
5. Coat a hollow or solid cylinder of the correct diameter with wax and tape it in place. Fill the gap between the cylinder and hull with casting epoxy. After the epoxy has set, remove the cylinder.
6. Sand and clean the area around the hole, inside and outside, to ensure that the sealant will adhere properly to the hull. If there is any petroleum residue inside the hull, remove it with either mild household detergent or a weak solvent (alcohol) before sanding.
7. Proceed with "Bedding" and "Installing" (see page 2).

Maintenance & Replacement

Aquatic growth can accumulate rapidly on the sensor's surface reducing its performance within weeks. Clean the surface with a Scotch-Brite® scour pad and mild household detergent taking care to avoid making scratches. If the fouling is severe, lightly wet sand with fine grade wet/dry paper.

Anti-fouling Paint

Surfaces exposed to salt water must be coated with anti-fouling paint. *Use water-based anti-fouling paint only.* Never use ketone-based paint since ketones can attack many plastics possibly damaging the sensor. Reapply anti-fouling paint every 6 months or at the beginning of each boating season.

Replacement Sensor & Parts

The information needed to order a replacement sensor is printed on the cable tag. Do not remove this tag. When ordering, specify the part number and date. For convenient reference, record this information at the top of page one.

Lost, broken, or worn parts should be replaced immediately.

Hull nut 02-031-3

Obtain parts from your instrument manufacturer or marine dealer.

Gemeco Tel: 803-693-0777
(USA) Fax: 803-693-0477
 email: sales@gemeco.com

Airmar EMEA Tel: +33.(0)2.23.52.06.48
(Europe, Middle East, Africa) Fax: +33.(0)2.23.52.06.49
 email: sales@airmar-emea.com

OWNER'S GUIDE & INSTALLATION INSTRUCTIONS

Surface Mount, Analog Temperature Sensor

Model T80

Record the information found on the cable tag for future reference.

Part No. _____ Date _____



05/28/14

17-584-01 rev. 01

Follow the precautions below for optimal product performance and to reduce the risk of property damage, personal injury, and/or death.

WARNING: Always wear safety goggles and a dust mask when installing.

WARNING: Below the waterline mount—When the boat is placed in the water, immediately check for leaks around the screws and any other holes drilled in the hull.

CAUTION: Installation on a metal hull—The stainless steel housing must be isolated from a metal hull to prevent electrolytic corrosion. Use marine sealant.

CAUTION: Never install a metal sensor on a vessel with a positive ground system.

IMPORTANT: Read the instructions completely before proceeding with the installation. These instructions supersede any other instructions in your instrument manual if they differ.

Tools & Materials

- Safety goggles
- Dust mask
- Pencil
- Electric drill
- Drill bit/hole saw/spade bit:
 - Pilot holes 3mm or 1/8"
 - Transom hole (some installations) 18mm or 3/4"
- 2 Stainless steel, self-tapping screws 4 x 18mm or #8 x 3/4"
- Marine sealant (suitable for below waterline)
- Screwdriver(s)
- Cable clamp(s) (some installations)
- Grommet(s) (some installations)
- Cable ties

Installation

Mounting on the transom

CAUTION: Mount the sensor as close to the centerline (keel) of the boat as possible to ensure the sensor remains in the water when the boat is turning (see Figure1).

CAUTION: Fiberglass hull—Minimize surface cracking by running the drill in reverse until the gelcoat is penetrated.

CAUTION: If the sensor came with a connector, do not remove it to ease cable routing. If the cable must be cut and spliced, use Airmar's splash-proof Junction Box No. 33-035 and follow the instructions provided. Removing the waterproof connector or cutting the cable, except when using a water-tight junction box, will void the sensor warranty.

Applications

- Measures air or water temperature.
- Stainless steel sensor is compatible with all hull materials. Recommended for aluminum hulls to prevent electrolytic corrosion, provided the stainless steel sensor is isolated from the metal hull by using marine sealant.

Mounting Location

The sensor can be mounted anywhere that you want to know the temperature. For example, you can mount the sensor on the transom, in the live well, or in the engine compartment.

If you are measuring water temperature, choose a location where the sensor will be in contact with the water at all times.

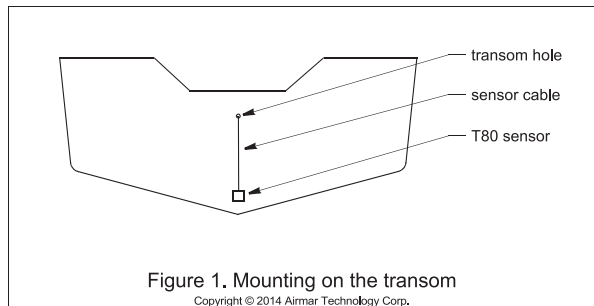

Figure 1. Mounting on the transom

Copyright © 2014 Airmar Technology Corp.

Mount the sensor near the centerline and close to the bottom of the transom.

Route the sensor cable over the transom, through a drain hole, or through a hole that you have drilled in the transom **above the waterline**.

1. Place the sensor against the hull and mark the position of the screw holes with a pencil.
2. Using a 3mm or 1/8" drill bit, drill pilot holes at the marked locations, 10mm (3/8") deep.
3. Apply marine sealant to the threads of the purchased screws to prevent water from seeping into the transom.
4. Screw the temperature sensor to the hull.
5. If a hole must be drilled through the transom, choose a location **well above the waterline**. Check for obstructions such as trim tabs, pumps, or wiring inside the hull. Mark the location with a pencil. Drill a hole through the transom using the appropriate size hole saw or spade bit (to accommodate the connector). Do NOT remove the connector.
6. Route the cable over or through the transom.
7. On the outside of the hull, secure the cable against the transom using a purchased cable clamp(s). Mark the position of the screw hole(s) with a pencil.
8. Using a 3mm or 1/8" drill bit, drill a pilot hole(s) at the marked locations, 10mm (3/8") deep.
9. Apply marine sealant to the threads of the screw(s) to prevent water from seeping into the transom.
10. Fasten the cable clamp(s) in place.
11. If a hole has been drilled through the transom, apply marine sealant to the space around the cable leading through the transom.

Cable Routing & Connecting

1. Route the cable to the instrument, being careful not to tear the cable jacket when passing it through the bulkhead(s) and other parts of the boat. To reduce electrical interference, separate the sensor cable from other electrical wiring and sources of noise. Coil any excess cable and secure it in place with cable ties to prevent damage.
2. Refer to the instrument owner's manual to connect the sensor to the instrument.

Replacement Sensor & Parts

The information needed to order a replacement sensor is printed on the cable tag. Do not remove this tag. When ordering, specify the part number and date. For convenient reference, record this information at the top of page one.

Obtain parts from your instrument manufacturer or marine dealer.

Gemeco
(USA)

Tel: 803-693-0777
Fax: 803-693-0477
email: sales@gemeco.com

Airmar EMEA
(Europe, Middle East, Africa)

Tel: +33.(0)2.23.52.06.48
Fax: +33.(0)2.23.52.06.49
email: sales@airmar-emea.com



35 Meadowbrook Drive, Milford, New Hampshire 03055-4613, USA
• www.airmar.com

**SPECIFICATIONS OF NETWORK SOUNDER
DFF3****1 GENERAL**

- 1.1 TX frequency 28-200kHz, two frequencies alternately (selectable)
- 1.2 Output power 1 to 3 kW nominal
- 1.3 Amplifier type Wide dynamic range linear amplifier (double superheterodyne)
- 1.4 Depth range and Pulse repetition rate (PRR)

200kHz, TX rate: 20

Range (m)	PRR (/min.)
2	2403 (max)
5	2403
10	1621
40	476
100	222
200	117
400	58
1200	34

2 INTERFACE

- 2.1 Number of port LAN: 1 port, Transducer: 2 port, Temp/speed sensor: 1 port
- 2.2 Network Ethernet 10BASE-T/100BASE-TX

3 POWER SUPPLY

- 3.1 Network sounder 12-24 VDC: 2.8-1.4 A
- 3.2 Rectifier (PR-62, option) 100/110/220/230VAC, 1 phase, 50/60Hz

4 ENVIRONMENTAL CONDITION

- 4.1 Ambient temperature -15°C to +55°C
- 4.2 Relative humidity 93% at 40°C
- 4.3 Degree of protection IP20
- 4.4 Bearing vibration IEC 60945

5 COATING COLOR

N2.5 (not changed)

PACKING LIST

02GF-X-9851 -1 1/1

DFF3-J/E

A-1

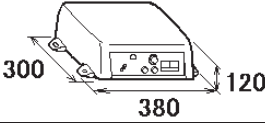
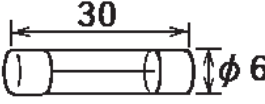
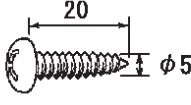
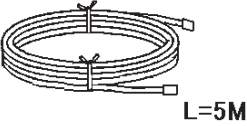
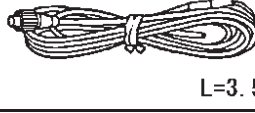
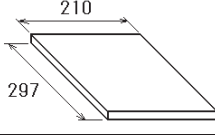
NAME	OUTLINE	DESCRIPTION/CODE No.	QTY
ユニット UNIT			
ネットワーク魚探 NETWORK SOUNDER		DFF3 000-011-916-00	1
予備品 SPARE PARTS SP02-05601			
ヒューズ GLASS TUBE FUSE		FGBO-A 125V 5A PBF 000-155-853-10	2
工事材料 INSTALLATION MATERIALS CP02-08500			
+トラスタップソネジ 1シユ SELF-TAPPING SCREW		5X20 SUS304 000-162-608-10	4
ケーブル(組品)LAN LAN CABLE ASSEMBLY		MOD-Z072-050+ 001-167-890-10	1
ケーブル組品MJ CABLE ASSEMBLY		MJ-A3SPF0013-035C (5A) 000-157-939-10	1
図書 DOCUMENT			
取扱説明書 OPERATOR'S MANUAL		OM*-20370-* 000-168-581-1* **	1

コード番号末尾の[**]は、選択品の代表コードを表します。
CODE NUMBER ENDING WITH "**" INDICATES THE CODE NUMBER OF REPRESENTATIVE MATERIAL.

型式/コード番号が2段の場合、下段より上段に代わる過渡期品であり、どちらかが入っています。なお、品質は変わりません。
TWO TYPES AND CODES MAY BE LISTED FOR AN ITEM. THE LOWER PRODUCT MAY BE SHIPPED IN PLACE OF THE UPPER PRODUCT. QUALITY IS THE SAME.

(略図の寸法は、参考値です。DIMENSIONS IN DRAWING FOR REFERENCE ONLY.)

表1 TABLE 1

寸法区分 (mm) DIMENSION	公差 (mm) TOLERANCE
$L \leq 50$	± 1.5
$50 < L \leq 100$	± 2.5
$100 < L \leq 500$	± 3

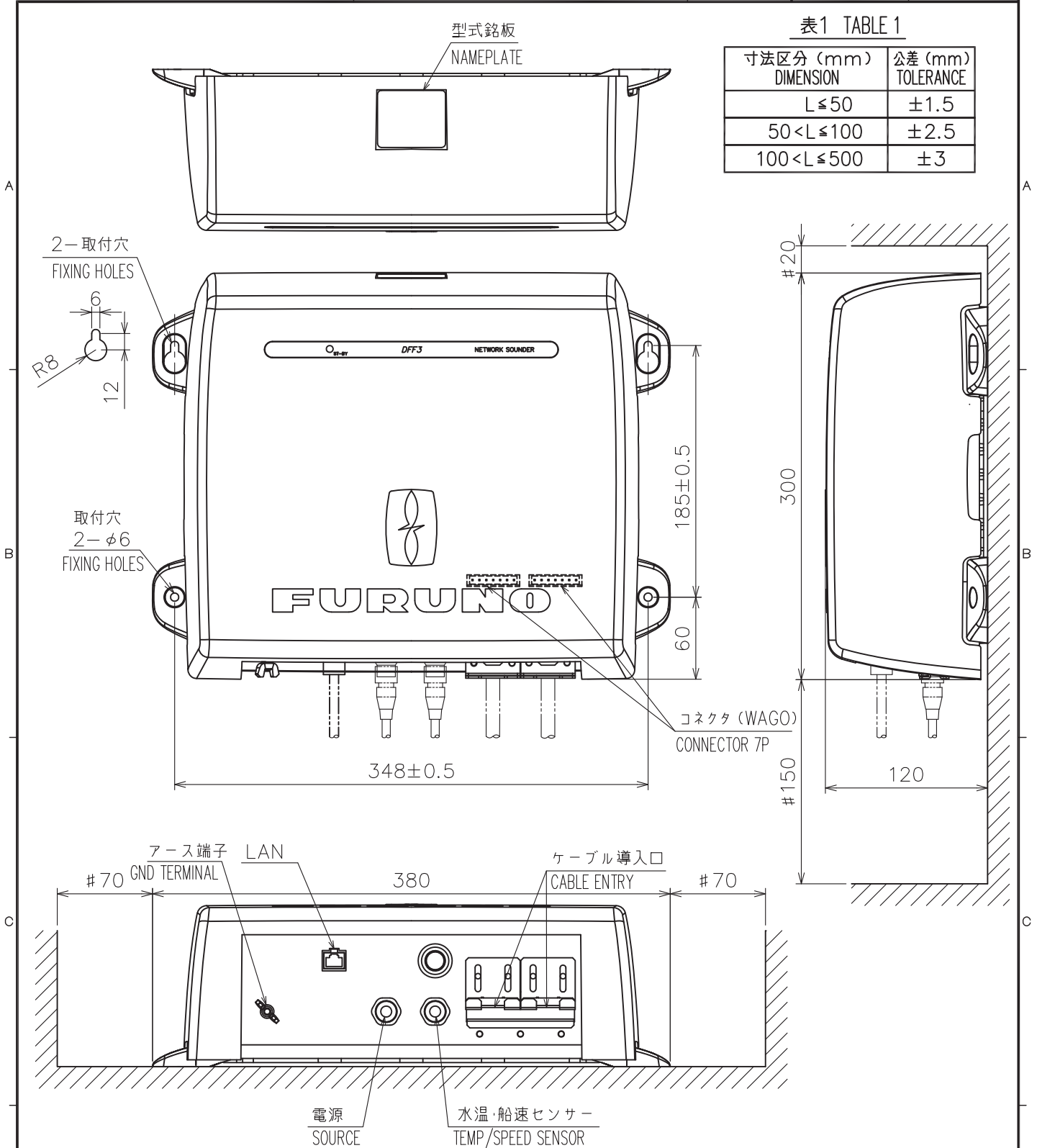

- 注 記 1) #印寸法は最小サービス空間寸法とする。
 2) 指定外の寸法公差は表1による。
 3) 取付用ネジはトラスタッピンネジ呼び径5×20を使用のこと。
- NOTE 1. # MINIMUM SERVICE CLEARANCE.
 2. TABLE 1 INDICATES TOLERANCE OF DIMENSIONS WHICH IS NOT SPECIFIED.
 3. USE TAPPING SCREWS 5x20 FOR FIXING THE UNIT.

DRAWN	26/Mar/08 T.YAMASAKI	TITLE	DFF3
CHECKED	27/Mar/08 T.TAKENO	名称	ネットワーク魚探
APPROVED	28/Mar/08 R.Esumi		外寸図
SCALE	1/4 MASS 3.9 ±10% kg	NAME	NETWORK SOUNDER
DWG.No.	C2037-G01-B	REF.No.	02-161-100G-1
		OUTLINE DRAWING	

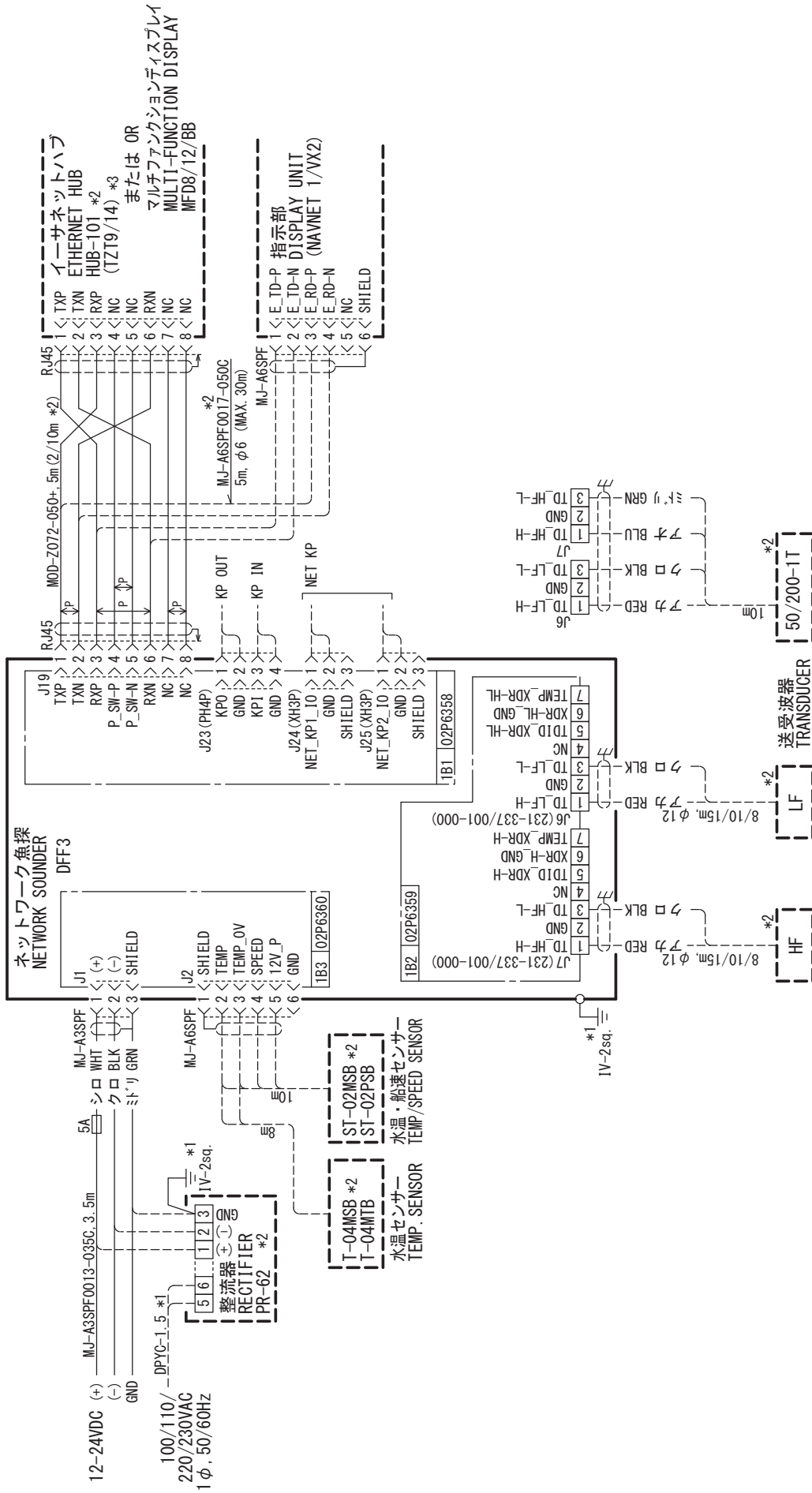

注記

- * 1) 造船所手配。
- * 2) オプション。
- * 3) DFF3のDIPスイッチ設定変更が必要。

NOTE

- * 1: SHIPYARD SUPPLY.
- * 2: OPTION.
- * 3: CHANGE DIP SWITCH SETTING OF DFF3.

DRAWN	26/Nov/2015	I. YAMASAKI	TITLE	DFF3
CHECKED	26/Nov/2015	H. MAKI	名称	ネットワーク魚探
APPROVED	26/Nov/2015	H. MAKI		相互結線図
SCALE	MASS	kg	NAME	NETWORK SOUNDER
DWG. No.	C2037-C01-J	REF. No.	02-161-1001-1	
INTERCONNECTION DIAGRAM				

FURUNO Worldwide Warranty for Pleasure Boats (Except North America)

This warranty is valid for products manufactured by Furuno Electric Co. (hereafter FURUNO) and installed on a pleasure boat. Any web based purchases that are imported into other countries by anyone other than a FURUNO certified dealer may not comply with local standards. FURUNO strongly recommends against importing these products from international websites as the imported product may not work correctly and may interfere with other electronic devices. The imported product may also be in breach of the local laws and mandated technical requirements. Products imported into other countries as described previously shall not be eligible for local warranty service.

For products purchased outside of your country please contact the national distributor of Furuno products in the country where purchased.

This warranty is in addition to the customer's statutory legal rights.

1. Terms and Conditions of Warranty

FURUNO guarantees that each new FURUNO product is the result of quality materials and workmanship. The warranty is valid for a period of 2 years (24 months) from the date of the invoice, or the date of commissioning of the product by the installing certified dealer.

2. FURUNO Standard Warranty

The FURUNO standard warranty covers spare parts and labour costs associated with a warranty claim, provided that the product is returned to a FURUNO national distributor by prepaid carrier.

The FURUNO standard warranty includes:

- Repair at a FURUNO national distributor
- All spare parts for the repair
- Cost for economical shipment to customer

3. FURUNO Onboard Warranty

If the product was installed/commissioned and registered by a certified FURUNO dealer, the customer has the right to the onboard warranty.

The FURUNO onboard warranty includes

- Free shipping of the necessary parts
- Labour: Normal working hours only
- Travel time: Up to a maximum of two (2) hours
- Travel distance: Up to a maximum of one hundred and sixty (160) KM by car for the complete journey

4. Warranty Registration

For the Standard Warranty - presentation of product with serial number (8 digits serial number, 1234-5678) is sufficient. Otherwise, the invoice with serial number, name and stamp of the dealer and date of purchase is shown.

For the Onboard Warranty your FURUNO certified dealer will take care of all registrations.

5. Warranty Claims

For the Standard Warranty - simply send the defective product together with the invoice to a FURUNO national distributor. For the Onboard Warranty – contact a FURUNO national distributor or a certified dealer. Give the product's serial number and describe the problem as accurately as possible.

Warranty repairs carried out by companies/persons other than a FURUNO national distributor or a certified dealer is not covered by this warranty.

6. Warranty Limitations

When a claim is made, FURUNO has a right to choose whether to repair the product or replace it.

The FURUNO warranty is only valid if the product was correctly installed and used. Therefore, it is necessary for the customer to comply with the instructions in the handbook. Problems which result from not complying with the instruction manual are not covered by the warranty.

FURUNO is not liable for any damage caused to the vessel by using a FURUNO product.

The following are excluded from this warranty:

- a. Second-hand product
- b. Underwater unit such as transducer and hull unit
- c. Routine maintenance, alignment and calibration services.
- d. Replacement of consumable parts such as fuses, lamps, recording papers, drive belts, cables, protective covers and batteries.
- d. Magnetron and MIC with more than 1000 transmitting hours or older than 12 months, whichever comes first.
- e. Costs associated with the replacement of a transducer (e.g. Crane, docking or diver etc.).
- f. Sea trial, test and evaluation or other demonstrations.
- g. Products repaired or altered by anyone other than the FURUNO national distributor or an authorized dealer.
- h. Products on which the serial number is altered, defaced or removed.
- i. Problems resulting from an accident, negligence, misuse, improper installation, vandalism or water penetration.
- j. Damage resulting from a force majeure or other natural catastrophe or calamity.
- k. Damage from shipping or transit.
- l. Software updates, except when deemed necessary and warrantable by FURUNO.
- m. Overtime, extra labour outside of normal hours such as weekend/holiday, and travel costs above the 160 KM allowance
- n. Operator familiarization and orientation.

FURUNO Electric Company, March 1, 2011

FURUNO Warranty for North America

FURUNO U.S.A., Limited Warranty provides a twenty-four (24) months LABOR and twenty-four (24) months PARTS warranty on products from the date of installation or purchase by the original owner. Products or components that are represented as being waterproof are guaranteed to be waterproof only for, and within the limits, of the warranty period stated above. The warranty start date may not exceed eighteen (18) months from the original date of purchase by dealer from Furuno USA and applies to new equipment installed and operated in accordance with Furuno USA's published instructions.

Magnetrons and Microwave devices will be warranted for a period of 12 months from date of original equipment installation.

Furuno U.S.A., Inc. warrants each new product to be of sound material and workmanship and through its authorized dealer will exchange any parts proven to be defective in material or workmanship under normal use at no charge for a period of 24 months from the date of installation or purchase.

Furuno U.S.A., Inc., through an authorized Furuno dealer will provide labor at no cost to replace defective parts, exclusive of routine maintenance or normal adjustments, for a period of 24 months from installation date provided the work is done by Furuno U.S.A., Inc. or an AUTHORIZED Furuno dealer during normal shop hours and within a radius of 50 miles of the shop location.

A suitable proof of purchase showing date of purchase, or installation certification must be available to Furuno U.S.A., Inc., or its authorized dealer at the time of request for warranty service.

This warranty is valid for installation of products manufactured by Furuno Electric Co. (hereafter FURUNO). Any purchases from brick and mortar or web-based resellers that are imported into other countries by anyone other than a FURUNO certified dealer, agent or subsidiary may not comply with local standards. FURUNO strongly recommends against importing these products from international websites or other resellers, as the imported product may not work correctly and may interfere with other electronic devices. The imported product may also be in breach of the local laws and mandated technical requirements. Products imported into other countries, as described previously, shall not be eligible for local warranty service.

For products purchased outside of your country please contact the national distributor of Furuno products in the country where purchased.

WARRANTY REGISTRATION AND INFORMATION

To register your product for warranty, as well as see the complete warranty guidelines and limitations, please visit www.furunousa.com and click on "Support". In order to expedite repairs, warranty service on Furuno equipment is provided through its authorized dealer network. If this is not possible or practical, please contact Furuno U.S.A., Inc. to arrange warranty service.

FURUNO U.S.A., INC.
Attention: Service Coordinator
4400 N.W. Pacific Rim Boulevard
Camas, WA 98607-9408
Telephone: (360) 834-9300
FAX: (360) 834-9400

Furuno U.S.A., Inc. is proud to supply you with the highest quality in Marine Electronics. We know you had several choices when making your selection of equipment, and from everyone at Furuno we thank you. Furuno takes great pride in customer service.



Declaration of Conformity



We **FURUNO ELECTRIC CO., LTD.**

(Manufacturer)

9-52 Ashihara-Cho, Nishinomiya City, 662-8580, Hyogo, Japan

(Address)

declare under our sole responsibility that the product

NETWORK SOUNDER DFF3

(Model name, type number)

to which this declaration relates conforms to the following standard(s) or other normative document(s)

EU
EMC Directive 2014/30/EU

UK
SI 2016 No.1091 EMC Regulations 2016 as amended

IEC 60945 Ed.4.0: 2002

EN 60945: 2002

For assessment, see

- Test report
Furuno Labotech International Co., Ltd.
FLI 12-08-007, 18 Feb 2008

For assessment, see

- Test report
Furuno Labotech International Co., Ltd.
FLI 12-08-007, 18 Feb 2008

(title and/or number and date of issue of the standard(s) or other normative document(s))

On behalf of Furuno Electric Co., Ltd.

Nishinomiya City, Japan
26 July 2021

(Place and date of issue)

Akihiko Kanechika
Department General Manager
Quality Assurance Department

(name and signature or equivalent marking of authorized person)



FURUNO ELECTRIC CO., LTD.

9-52, Ashihara-cho,
Nishinomiya, 662-8580, JAPAN

·FURUNO Authorized Distributor/Dealer

All rights reserved. Printed in Japan

A: MAR. 2008
H1: AUG. 07, 2023

Pub. No. OME-20370-H1
(TEHI) DFF3

