

R399

2 to 3 kW

Dual-Frequency

Preliminary



Lower the frequencies for your fishing.

Frequency Agility

Airmar's new Broadband R399 is different from the R299 because it operates at lower frequencies between 25 kHz to 45 kHz and 130 kHz to 210 kHz. Adjusting the frequency allows you to change the R399's beamwidth and depth capabilities. For example if you are bottom fishing in 61 m (200') of water, the narrow high-frequency beam will display extreme bottom detail and fish holding tight to structure. If you are tuna or marlin fishing in deep blue water, the wider, low-frequency beam will not only give deep-water bottom detail, but more importantly show you more of what is around your vessel—including bait which may attract game fish.

Power to Beat the Band

Widen the band and increase the catch with the R399. Because the R399 has a bandwidth that covers a continuous frequency spectrum, next generation fishfinders can be made "tunable", so fishermen can "dial-in" the best frequency for the target fish species or conditions.

- The best in-hull performer in Airmar's professional line of fishfinder transducers for vessels 12 m (40') and up
- Only transducer on the market that can operate at both 28 or 38 kHz
- Super low ringing for accurate discrimination between closely spaced targets
- Recommended for solid fiberglass hulls
- Can be externally mounted in a conventional steel tank
- Non-toxic anti-freeze (propylene glycol) is used to fill the tank
- MarineTex™ epoxy is used to adhere tank to the hull





R399

2 to 3 kW

Dual-Frequency

Technical Information

Specifications

Frequencies	Number of Elements and Configuration	Rated RMS Power (W)	TVR	RVR
25-45 kHz-A		3 kW	169dB	-167dB
130-210 kHz-BRLq		2 kW	172dB	-184dB

Weight: 27.5 kg (60.6 lb)

Hull Deadrise Angle: 0° to 25°

	25-45 kHz	130-210 kHz
FOM*	-5	-12
Q	3	2

*does not calculate losses through the hull.

Figure of Merit

The graph shows that the R399 can run optimally at a wide range of frequencies.

As Airmar constantly improves its products, all specifications are subject to change without notice. All Airmar products are designed to provide high levels of accuracy and reliability; however, they should only be used as aids to navigation and not as a replacement for traditional navigation aids and techniques.

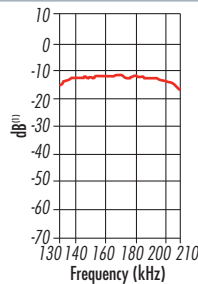
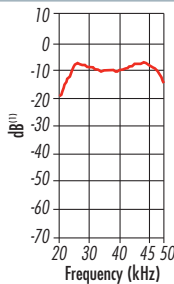

R399 Dimensions

R399 transducer

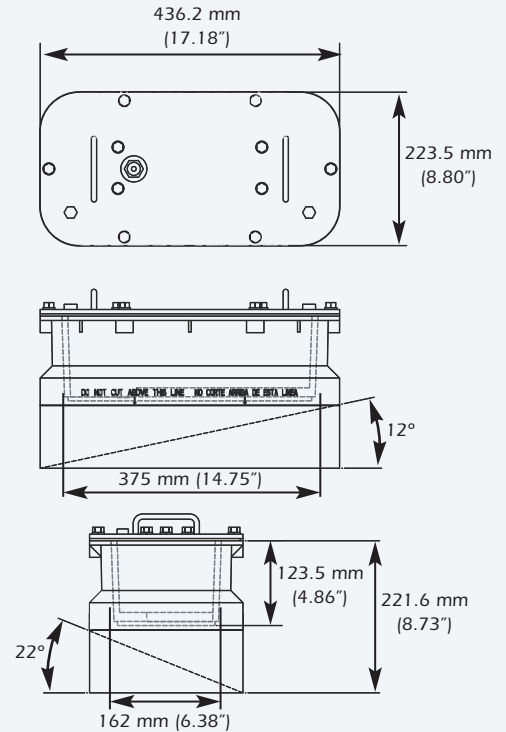

Directivity Patterns

